

Chowchilla Water District
Regular Meeting of the Board of Directors
Wednesday, May 11th, 2022
1:30 P.M. – District Office
327 South Chowchilla Boulevard
Chowchilla, CA 93610

This Page is Blank Intentionally

CHOWCHILLA WATER DISTRICT
REGULAR MEETING OF THE BOARD OF DIRECTORS
WEDNESDAY, MAY 11th, 2022
AT 1:30 P.M. AT THE DISTRICT OFFICE
327 S. Chowchilla Blvd., Chowchilla, CA

AGENDA

For those that are unable to attend in person, please use the following number to join:

Toll-Free Access Number: 877-594-8353

Participant Pass Code: 66771076

1. Call to order
2. Public Comment – The first 15 minutes is made available for comments from the public on matters within the Board's jurisdiction that are not on this Agenda. Each speaker will be limited to three minutes. It is requested that no comments be made during this period on items that are on today's Agenda. Members of the public may comment on any item that is on today's Agenda when the item is called.
3. Additions to the Agenda – Items identified after preparation of the agenda for which there is a need to take immediate action. Two-thirds vote required for consideration. (Govt. Code, § 54954.2(g)(2).)

RECESS AS CWD BOARD OF DIRECTORS & CONVENE AS CWD GROUNDWATER SUSTAINABILITY AGENCY

- a. This item may include the attendance of the General Resource Manager (Doug Welch) who will provide an update on GSA activities (by phone or memo if not in attendance)

ADJOURN AS CWD GROUNDWATER SUSTAINABILITY AGENCY AND RECONVENE AS CWD BOARD OF DIRECTORS

4. Financial Reports:
 - A. Treasurer's Report
 - B. Payment of Bills
5. 2022 Budget vs. Actual Income & Expense Comparison
6. **Resolution 2022-04** - The board will discuss and may take action to approve RESOLUTION 2022-04 A RESOLUTION ADOPTING THE CHOWCHILLA WATER DISTRICT DESIGN STANDARDS AND CONSTRUCTION SPECIFICATIONS
7. Approval of Minutes – April 20th, 2022
8. General Manager's Report
 - A. O&M Report
 - B. 2022 Water Season Update
9. 2022 Water Season – The Board will discuss and may take action regarding the sale, delivery, and pricing of 2022 water supply.
10. Conference with Legal Counsel, Anticipated Litigation (Govt. Code, § 54956.9(d)(4): Three Items.
11. Conference with Legal Counsel, Existing Litigation (Govt. Code, § 54956.9(d)(1):
 - A. Natural Resources Defense Council et al. v. David Murillo et al., United States District Court Case No. Case No. CIV 2-88-cv-01658-(E.D. CA)
 - B. City of Fresno et al. v. United States, United States Court of Federal Court of Claims Case No. 1:55-cv-01000-UNJ

12. Director's Reports - This item provides an opportunity for the Directors to share information on meetings attended on the District's behalf and discuss any concerns in the operation of the District.

13. Adjournment

ACCOMMODATIONS FOR PERSONS WITH DISABILITIES

A person with a qualifying disability under the Americans with Disabilities Act of 1990 may request the District to provide a disability-related modification or accommodation in order to participate in any public meeting of the District. Such assistance includes appropriate alternative formats for the agendas and agenda packets used for any public meetings of the District. Requests for such assistance and for agendas and agenda packets shall be made in person, by telephone, facsimile, or written correspondence to Brandon Tomlinson (559) 665-3747 at the District office, at least 48 hours before a public District meeting.

Staff reports and other disclosable records related to open session agenda items are available at the District office located at 327 S. Chowchilla Blvd., Chowchilla, CA during business hours, Monday through Friday, 8 AM to 5 PM.

TREASURER'S REPORT

This Page is Blank Intentionally

**CHOWCHILLA WATER DISTRICT
TREASURER'S REPORT
May 1, 2022**

	Beginning Balance April 1, 2022	Receipts	Transfers In(Out)	Disbursements	Ending Balance May 1, 2022
Bank of America - General Fund	\$ 9,154,108.84	\$ 73,332.86	\$ -	\$ (305,518.02)	\$ 8,921,923.68
Tri Counties Bank - General Fund	\$ 35,079.65	\$ 444.75	\$ -	-	\$ 35,524.40
Bank of America - Maximizer	\$ 1,940,442.45	\$ -	\$ -	-	\$ 1,940,442.45
Bank of America - 1 Year CD					
Unrestricted Reserves	\$ 208,516.58	-			\$ 208,516.58
System Improvements	\$ 737,161.05	-			\$ 737,161.05
Bank of America					
Installment Purchase Reserve	\$ 1,707,157.14	-			\$ 1,707,157.14
LAIF - Unrestricted Reserves	\$ 2,034,594.58	782.75			\$ 2,035,377.33
LAIF - System Improvements	\$ 6,018.32	2.32			\$ 6,020.64
Cash Funds	\$ 550.00		\$ -	-	\$ 550.00
	<u>\$ 15,823,628.61</u>	<u>\$ 74,562.68</u>	<u>\$ -</u>	<u>\$ (305,518.02)</u>	<u>\$ 15,592,673.27</u>
Unrestricted Funds	\$ 13,373,292.10				\$ 13,142,334.44
Restricted Funds	<u>\$ 2,450,336.51</u>				<u>\$ 2,450,338.83</u>
	<u>\$ 15,823,628.61</u>				<u>\$ 15,592,673.27</u>

Chowchilla Water District

TREASURER'S REPORT

May 1, 2022

Beginning Balance: April 1, 2022 15,823,628.61

INCOME

2021 Crop Water Receivable	38.19
2022 Crop Water Receivable	1,779.89
Interest - Crop Water	55.93
2015-16 Assessments Receivable	26.02
2016-17 Assessments Receivable	39.00
2017-18 Assessments Receivable	34.02
2020-21 Assessments Receivable	163.01
2021-22 Assessments Receivable	983.91
Penalties-Assessments	85.93
Recording Fees	269.85
Interest - Assessments	39.40
Legal Advertising Fees	366.50
Interest & Dividend Revenue	785.07
2021-22 Supplemental Assessment	180.80
2021-22 Capital Repayment Assessment	248.60
Accounts Receivable	40,930.91
Prepaid Assessment	69.00
Surplus Equipment	1,125.00
Miscellaneous Revenue	983.68
Refunds	26,357.97
	74,562.68

TOTAL INCOME \$ 74,562.68

EXPENDITURES

General Fund (305,518.02)

TOTAL EXPENDITURES (305,518.02)

TOTAL CASH \$15,592,673.27

Bank Balance: April 1, 2022

Bank of America - General Fund

Beginning Balance \$ 9,154,108.84

Deposits:

Income	73,332.86
Transfers in	-
Total Deposits:	73,332.86

Expenditures:

Disbursements	(257,572.51)
EFTPS - Payroll Taxes; Pension; Child Support	(47,945.51)
Transfers out	-
Total Expenditures:	(305,518.02)

Ending Balance May 1, 2022 \$ 8,921,923.68

Chowchilla Water District

TREASURER'S REPORT

May 1, 2022

Tri Counties Bank - General Fund			
Beginning Balance		\$ 35,079.65	
Deposits:			
Income	444.75		
Total Deposits:		444.75	
Expenditures:			
Disbursements	-		
Total Expenditures:		-	
Ending Balance			\$ 35,524.40
Bank of America - Maximizer			
Beginning Balance		\$ 1,940,442.45	
Interest Earned	0.00%		
Ending Balance			\$ 1,940,442.45
Bank of America - 1 Year CD			
Unrestricted Reserves	208,516.58		
Ending Balance		208,516.58	
System Improvements	737,161.05		
Ending Balance		737,161.05	
Ending Balance			\$ 945,677.63
Bank of America - Installment Purchase Reserve			
Beginning Balance		1,707,157.14	
Ending Balance			\$ 1,707,157.14
<i>Bank Totals</i>			\$13,550,725.30
LAIF - Unrestricted Reserves			
Beginning Balance		2,034,594.58	
Allocated Interest	0.32%	782.75	
Ending Balance			\$ 2,035,377.33
LAIF - System Improvements			
Beginning Balance		6,018.32	
Allocated Interest	0.32%	2.32	
Ending Balance			\$ 6,020.64
<i>LAIF Total</i>			\$2,041,397.97
Cash Funds			\$ 550.00
TOTAL CASH			\$ 15,592,673.27

 Lela Beatty, Treasurer

**CHOWCHILLA WATER DISTRICT
CASH DIAGRAM
May 1, 2022**

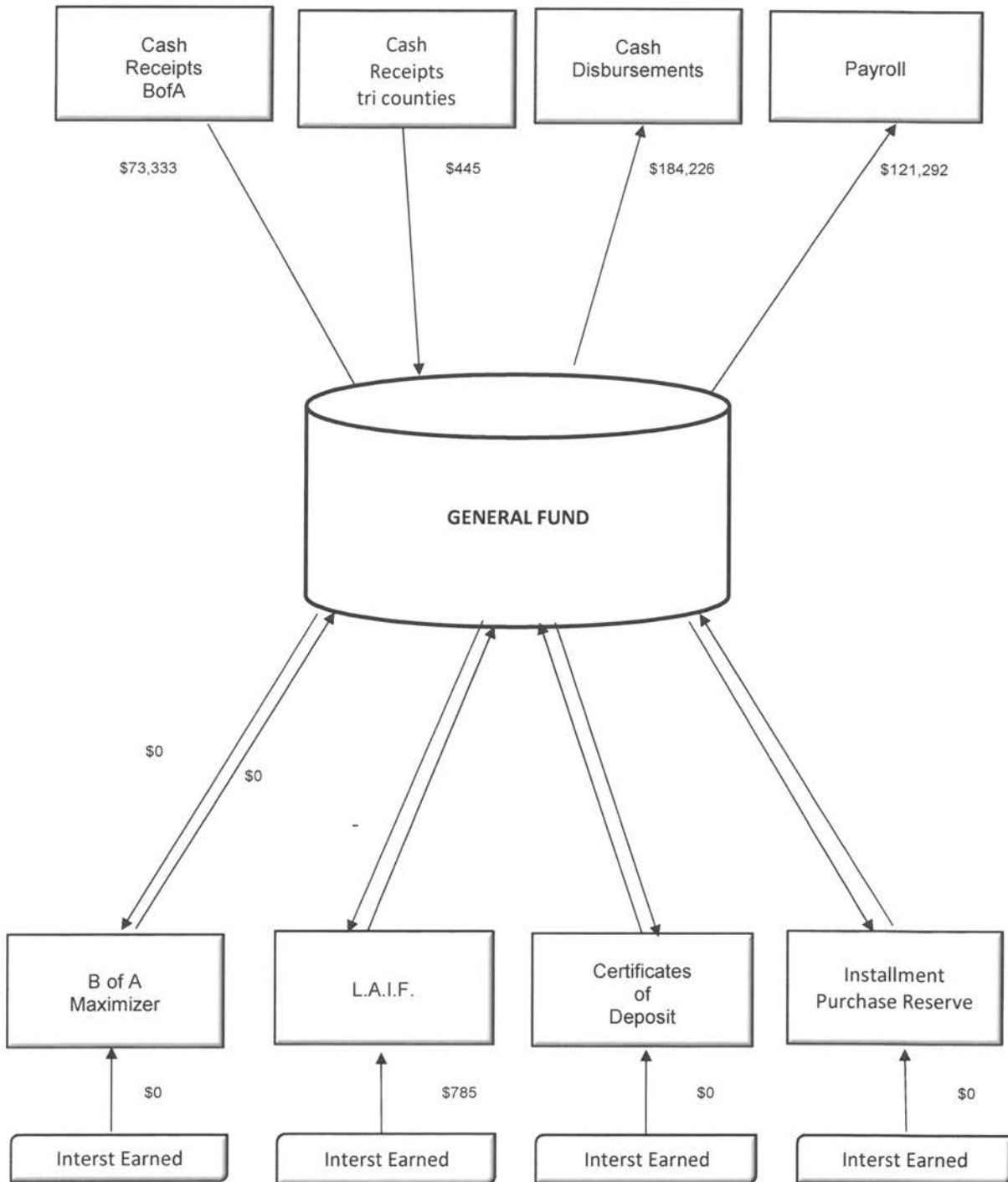

**CHOWCHILLA WATER DISTRICT
CASH SUMMARY
2013 - 2022**

	2013	2014	2015	2016	2017	2018	2019	2020	2021	2022
January	12,606,792	14,341,188	12,970,611	11,253,822	10,303,598	15,098,280	17,041,392	19,715,387	19,570,683	17,267,563
February	12,024,992	13,780,643	12,254,336	10,249,568	9,703,310	14,421,083	16,515,339	19,004,027	19,333,612	16,589,725
March	11,726,340	13,584,204	11,935,106	9,447,541	9,689,325	14,147,377	15,539,360	18,517,751	18,774,212	15,823,629
April	10,852,828	13,383,111	11,405,995	9,462,301	9,512,383	13,684,385	14,434,475	17,871,848	18,314,960	15,592,673
May	10,235,624	11,999,670	9,457,529	7,163,495	7,599,486	10,966,469	13,583,620	14,378,517	16,388,207	
June	8,997,132	10,865,247	10,485,436	5,945,609	7,848,796	11,083,680	13,215,996	13,352,153	15,958,566	
July	9,428,375	10,990,714	10,844,774	7,300,874	9,754,037	12,889,434	14,624,652	15,545,956	16,659,843	
August	10,811,794	10,936,340	11,041,186	9,783,821	11,754,822	14,658,793	17,073,103	17,831,895	17,388,951	
September	12,001,275	11,348,754	9,777,147	8,603,485	12,132,805	15,452,212	17,631,221	19,697,829	16,980,418	
October	12,041,380	11,329,994	9,745,641	8,545,325	13,168,831	15,108,162	18,243,994	19,771,871	16,721,462	
November	12,440,802	11,514,318	9,696,995	7,562,164	12,427,279	14,081,421	17,985,664	19,114,397	15,722,732	
December	12,950,451	11,738,464	10,187,677	8,766,289	13,209,000	15,841,986	18,255,737	19,665,016	16,017,474	

This Page is Blank Intentionally

PAYMENT
OF
BILLS
REPORT

This Page is Blank Intentionally

Chowchilla Water District

Post Office Box 905 ♦ 327 S. Chowchilla Blvd. ♦ Chowchilla, CA 93610

Phone (559) 665-3747

Fax (559) 665-3740

—
Board of Directors

Michael Mandala ♦ Vince Taylor ♦ Kole M. Upton ♦ Russell Harris ♦ Roger Schuh

~~~~~

*May 11<sup>th</sup>, 2022*

## *General Account*

➤ *Warrant No. 030858 thru 030919 – 4/21/2022 thru 5/11/2022 Total \$722,572.47*

***Total Amount Disbursed \$722,572.47***

*Approved for payment by the Board of Directors*

*~May 11<sup>th</sup>, 2022~*

---

---

---

---

---

---

This Page is Blank Intentionally



**Check History Report**  
**Sorted By Check Number**  
**Activity From: 4/21/2022 to 5/11/2022**

**Chowchilla Water District (CWD)**

**Bank Code:** A B of A - CHECKING ACCOUNT

| <b>Check Number</b> | <b>Check Date</b> | <b>Vendor Number</b> | <b>Name</b>                              | <b>Check Amount</b> | <b>Check Type</b> |
|---------------------|-------------------|----------------------|------------------------------------------|---------------------|-------------------|
| 030858              | 4/26/2022         | 00-A8377             | Alhambra & Sierra Springs                | 41.28               | Auto              |
| 030859              | 4/26/2022         | 00-B3650             | Blue Shield of California                | 2,690.30            | Auto              |
| 030860              | 4/26/2022         | 00-B9923             | Bob's Community Pest Control             | 105.00              | Auto              |
| 030861              | 4/26/2022         | 00-BS3650S           | Blue Shield of California                | 1,932.00            | Auto              |
| 030862              | 4/26/2022         | 00-C6630             | CALOLYMPIC SAFETY                        | 505.67              | Auto              |
| 030863              | 4/26/2022         | 00-G5707             | Grainger Parts                           | 1,730.22            | Auto              |
| 030864              | 4/26/2022         | 00-LIN4449           | Linde Gas & Equipment, Inc.              | 474.87              | Auto              |
| 030865              | 4/26/2022         | 00-M2660             | MID-VALLEY DISTRIBUTORS, INC.            | 171.70              | Auto              |
| 030866              | 4/26/2022         | 00-M7724             | MADERA COUNTY RECORDER OFFICE            | 50.00               | Auto              |
| 030867              | 4/26/2022         | 00-P5000P            | Pacific Gas & Electric Company           | 320.03              | Auto              |
| 030868              | 4/26/2022         | 00-S3701             | Steves Chevrolet (Inc)                   | 88.69               | Auto              |
| 030869              | 4/26/2022         | 00-S5998             | SJVAPCD - San Joaquin Valley             | 80.00               | Auto              |
| 030870              | 4/26/2022         | 00-T4414             | Terra Bella Irrigation District          | 625.28              | Auto              |
| 030871              | 4/26/2022         | 00-VAN3421           | VAN DE POL                               | 2,647.81            | Auto              |
| 030872              | 5/6/2022          | 00-C7453             | CitiBusiness Card                        | 8,276.59            | Auto              |
| 030872              | 5/6/2022          | 00-C7453             | CitiBusiness Card                        | 8,276.59-           | Reversal          |
| 030873              | 5/6/2022          | 00-C7453             | CitiBusiness Card                        | 8,276.59            | Auto              |
| 030874              | 5/11/2022         | 00-A2009             | Abbey Door Service                       | 630.00              | Auto              |
| 030875              | 5/11/2022         | 00-A2292             | ACWA-JPIA (HBA)                          | 30,483.08           | Auto              |
| 030876              | 5/11/2022         | 00-A2394             | Alview-Dairyland Union                   | 1,052.00            | Auto              |
| 030877              | 5/11/2022         | 00-A4261             | Aanonson Sprinkler Co., Inc.             | 5.93                | Auto              |
| 030878              | 5/11/2022         | 00-B4891             | Blacks Irrigation Systems, Inc           | 3,219.65            | Auto              |
| 030879              | 5/11/2022         | 00-B5128             | Bureau of Reclamation                    | 519,392.50          | Auto              |
| 030880              | 5/11/2022         | 00-BSK2888           | BSK Associates                           | 827.00              | Auto              |
| 030881              | 5/11/2022         | 00-C3000             | Comcast                                  | 539.75              | Auto              |
| 030882              | 5/11/2022         | 00-C6630             | CALOLYMPIC SAFETY                        | 73.33               | Auto              |
| 030883              | 5/11/2022         | 00-C8846             | Central Valley Concrete, Inc.            | 625.31              | Auto              |
| 030884              | 5/11/2022         | 00-CIN0183           | Cintas Corporation #621                  | 875.45              | Auto              |
| 030885              | 5/11/2022         | 00-D7770             | Divine Logic, Inc.                       | 340.95              | Auto              |
| 030886              | 5/11/2022         | 00-DAV6107           | Davids Engineering, Inc.                 | 16,856.25           | Auto              |
| 030887              | 5/11/2022         | 00-E2853             | esri-ENVIRONMENTAL SYSTEMS RESEARCH INST | 1,200.00            | Auto              |
| 030888              | 5/11/2022         | 00-F6684             | Fresno Oxygen                            | 245.46              | Auto              |
| 030889              | 5/11/2022         | 00-F9000             | Farmers Hardware & Supply                | 124.09              | Auto              |
| 030890              | 5/11/2022         | 00-FW6305            | Friant Water Authority-SLDMWA            | 29,827.22           | Auto              |
| 030891              | 5/11/2022         | 00-H1946             | Home Depot Credit Services               | 404.93              | Auto              |
| 030892              | 5/11/2022         | 00-H6620             | Holt of California (Inc.)                | 222.42              | Auto              |
| 030893              | 5/11/2022         | 00-K1000             | Klein DeNatale Goldner Attorneys At Law  | 7,356.50            | Auto              |
| 030894              | 5/11/2022         | 00-K1501             | Kellogg's Supply                         | 117.86              | Auto              |
| 030895              | 5/11/2022         | 00-L1408             | Lowe's Business Account                  | 2,254.96            | Auto              |
| 030896              | 5/11/2022         | 00-L1615             | L&L Electrical                           | 4,459.05            | Auto              |
| 030897              | 5/11/2022         | 00-LAW7664           | Lawson Products                          | 1,434.40            | Auto              |
| 030898              | 5/11/2022         | 00-M0526             | Moore Quality Galvanizing L.P.           | 270.63              | Auto              |
| 030899              | 5/11/2022         | 00-M7228             | Midland Tractor                          | 47.91               | Auto              |
| 030900              | 5/11/2022         | 00-M7431             | Merced County Department of Ag           | 1,380.00            | Auto              |
| 030901              | 5/11/2022         | 00-M7521             | Mid-Valley Pipe & Steel, Inc.            | 380.08              | Auto              |
| 030902              | 5/11/2022         | 00-M7724             | MADERA COUNTY RECORDER OFFICE            | 720.00              | Auto              |
| 030903              | 5/11/2022         | 00-MC3514            | Madera Chowchilla Water & Powe           | 33,555.61           | Auto              |
| 030904              | 5/11/2022         | 00-O3633             | The Office City                          | 247.73              | Auto              |
| 030905              | 5/11/2022         | 00-ORE9031           | O'Reilly Auto Parts                      | 1,372.82            | Auto              |
| 030906              | 5/11/2022         | 00-P5000S            | Pacific Gas & Electric Company           | 168.91              | Auto              |
| 030907              | 5/11/2022         | 00-P6121             | Platt                                    | 29.78               | Auto              |
| 030908              | 5/11/2022         | 00-P8999             | ParcelQuest                              | 2,399.00            | Auto              |
| 030909              | 5/11/2022         | 00-R&S9670           | R&S Erection Tri-County, INC.            | 1,045.00            | Auto              |
| 030910              | 5/11/2022         | 00-S4446             | S & W Parts Inc.                         | 29.01               | Auto              |

**Check History Report**  
**Sorted By Check Number**  
**Activity From: 4/21/2022 to 5/11/2022**

**Chowchilla Water District (CWD)**

**Bank Code:** A B of A - CHECKING ACCOUNT

| <b>Check Number</b>  | <b>Check Date</b> | <b>Vendor Number</b> | <b>Name</b>                  | <b>Check Amount</b>      | <b>Check Type</b> |
|----------------------|-------------------|----------------------|------------------------------|--------------------------|-------------------|
| 030911               | 5/11/2022         | 00-S4658             | Schoettler Tire, Inc.        | 64.35                    | Auto              |
| 030912               | 5/11/2022         | 00-S7505             | Spriggs Inc.                 | 328.03                   | Auto              |
| 030913               | 5/11/2022         | 00-T1207             | Technoflo Systems            | 5,520.73                 | Auto              |
| 030914               | 5/11/2022         | 00-T4952             | TF Tire & Service            | 2,346.93                 | Auto              |
| 030915               | 5/11/2022         | 00-U2438             | Upton, Kole M.               | 705.33                   | Auto              |
| 030916               | 5/11/2022         | 00-V3900             | Valley Iron, Inc.            | 2,958.11                 | Auto              |
| 030917               | 5/11/2022         | 00-VAN3421           | VAN DE POL                   | 2,384.00                 | Auto              |
| 030918               | 5/11/2022         | 00-VER0204           | Verizon Wireless             | 1,285.07                 | Auto              |
| 030919               | 5/11/2022         | 00-W9269             | Western Ag Irrigation, Inc.  | 5,420.99                 | Auto              |
| 409422               | 4/29/2022         | 00-N4224             | Nationwide Trust Co. FSB     | 3,918.91                 | Manual            |
| 456114               | 4/29/2022         | 00-E5616             | Employment Development Dept. | 1,500.59                 | Manual            |
| 457114               | 4/27/2022         | 00-N4224             | Nationwide Trust Co. FSB     | 324.53                   | Manual            |
| 941114               | 4/29/2022         | 00-I3201             | Internal Revenue Service     | 11,860.89                | Manual            |
| <b>Bank A Total:</b> |                   |                      |                              | <u>722,572.47</u>        |                   |
| <b>Report Total:</b> |                   |                      |                              | <u><u>722,572.47</u></u> |                   |

**Chowchilla Water District**  
**Check Report**

Report Parameters:

Report Format: Invoice Level Detail

For Check Dates 4/21/2022 through 5/11/2022

For Vendors 00-0000000 through 99-ZZZZZZZ

**Bank Code: A**

| Check # | Date             | Vendor Number   | Vendor Name                        | Check Amount     |
|---------|------------------|-----------------|------------------------------------|------------------|
| 030858  | 4/26/2022        | 00-A8377        | Alhambra & Sierra Springs          | 41.28            |
|         | <u>Invoice #</u> | <u>Date</u>     | <u>Invoice Comment</u>             | <u>Inv. Amt.</u> |
|         | 7117807          | 0416224/16/2022 | Office / Bottled Water             | 41.28            |
| 030859  | 4/26/2022        | 00-B3650        | Blue Shield of California          | 2,690.30         |
|         | <u>Invoice #</u> | <u>Date</u>     | <u>Invoice Comment</u>             | <u>Inv. Amt.</u> |
|         | 221010187334     | 4/11/2022       | Directors Benefits-Taylor/2022-MAY | 2,690.30         |
| 030860  | 4/26/2022        | 00-B9923        | Bob's Community Pest Control       | 105.00           |
|         | <u>Invoice #</u> | <u>Date</u>     | <u>Invoice Comment</u>             | <u>Inv. Amt.</u> |
|         | 0415224980       | 4/15/2022       | B&G / Pest Control - APR           | 105.00           |
| 030861  | 4/26/2022        | 00-BS3650S      | Blue Shield of California          | 1,932.00         |
|         | <u>Invoice #</u> | <u>Date</u>     | <u>Invoice Comment</u>             | <u>Inv. Amt.</u> |
|         | 20220425         | 4/25/2022       | Directors Benefits-Schuh/2022-MAY  | 1,932.00         |
| 030862  | 4/26/2022        | 00-C6630        | CALOLYMPIC SAFETY                  | 505.67           |
|         | <u>Invoice #</u> | <u>Date</u>     | <u>Invoice Comment</u>             | <u>Inv. Amt.</u> |
|         | 397765           | 4/13/2022       | Safety / Oxy Sensor for QRae       | 290.72           |
|         | 398050           | 4/19/2022       | Safety/Respirators, Cartirdges     | 214.95           |
| 030863  | 4/26/2022        | 00-G5707        | Grainger Parts                     | 1,730.22         |
|         | <u>Invoice #</u> | <u>Date</u>     | <u>Invoice Comment</u>             | <u>Inv. Amt.</u> |
|         | 9272399735       | 4/7/2022        | Canal / Pipe Painter Rollers       | 227.51           |
|         | 9272435513       | 4/7/2022        | Membership / Grainger - Red Pass   | 140.29           |
|         | 9272626780       | 4/7/2022        | Canal / Gray Enamel Paint          | 1,362.42         |
| 030864  | 4/26/2022        | 00-LIN4449      | Linde Gas & Equipment, Inc.        | 474.87           |
|         | <u>Invoice #</u> | <u>Date</u>     | <u>Invoice Comment</u>             | <u>Inv. Amt.</u> |
|         | 69991457         | 4/14/2022       | Canal/ Welding - Wire & Wheels     | 474.87           |
| 030865  | 4/26/2022        | 00-M2660        | MID-VALLEY DISTRIBUTORS, INC.      | 171.70           |
|         | <u>Invoice #</u> | <u>Date</u>     | <u>Invoice Comment</u>             | <u>Inv. Amt.</u> |
|         | 1237661          | 4/14/2022       | Canal / Fasteners                  | 171.70           |
| 030866  | 4/26/2022        | 00-M7724        | MADERA COUNTY RECORDER OFFICE      | 50.00            |
|         | <u>Invoice #</u> | <u>Date</u>     | <u>Invoice Comment</u>             | <u>Inv. Amt.</u> |

**Chowchilla Water District**  
**Check Report**

Report Parameters:

Report Format: Invoice Level Detail

For Check Dates 4/21/2022 through 5/11/2022

For Vendors 00-0000000 through 99-ZZZZZZZ

**Bank Code: A**

| Check # | Date                    | Vendor Number | Vendor Name                              | Check Amount |
|---------|-------------------------|---------------|------------------------------------------|--------------|
|         | 2022-05-CD              | 4/25/2022     | Office / Deeds on 2 CD's for May 2022    | 50.00        |
| 030867  | 4/26/2022               | 00-P5000P     | Pacific Gas & Electric Company           | 320.03       |
|         | Invoice #               | Date          | Invoice Comment                          | Inv. Amt.    |
|         | 20220414                | 4/14/2022     | Pump Electrical Expense / MAR            | 320.03       |
| 030868  | 4/26/2022               | 00-S3701      | Steves Chevrolet (Inc)                   | 88.69        |
|         | Invoice #               | Date          | Invoice Comment                          | Inv. Amt.    |
|         | 2000944                 | 4/18/2022     | 54222: 10-17 thermo cooler val           | 88.69        |
| 030869  | 4/26/2022               | 00-S5998      | SJVAPCD - San Joaquin Valley             | 80.00        |
|         | Invoice #               | Date          | Invoice Comment                          | Inv. Amt.    |
|         | 334102                  | 4/30/2022     | Canal/BurnPermit Merced                  | 80.00        |
| 030870  | 4/26/2022               | 00-T4414      | Terra Bella Irrigation District          | 625.28       |
|         | Invoice #               | Date          | Invoice Comment                          | Inv. Amt.    |
|         | 3173                    | 4/8/2022      | Joint Defense Expense                    | 625.28       |
| 030871  | 4/26/2022               | 00-VAN3421    | VAN DE POL                               | 2,647.81     |
|         | Invoice #               | Date          | Invoice Comment                          | Inv. Amt.    |
|         | CL24382                 | 4/15/2022     | DSL 149.373g / GAS 406.014g              | 2,647.81     |
| 030873  | 5/6/2022                | 00-C7453      | CitiBusiness Card                        | 8,276.59     |
|         | Invoice #               | Date          | Invoice Comment                          | Inv. Amt.    |
|         | 113-8319478-244/19/2022 |               | Canal / Utility Knives, Duct Tape, Shims | 88.84        |
|         | 20220323AMA- 3/23/2022  |               | Office / P-touch Tape                    | 27.17        |
|         | 20220323GOO- 3/23/2022  |               | Hospitality/ Refreshments for Safety Mtg | 35.75        |
|         | 20220323SAV-C3/23/2022  |               | Hospitality / Food for Drill Training    | 17.18        |
|         | 20220323STA-B3/23/2022  |               | Hospitality / Coffee for Drill Training  | 115.00       |
|         | 20220324BAK-B3/24/2022  |               | Canal / Welding Supplies                 | 131.57       |
|         | 20220324GOO- 3/24/2022  |               | 56809-02-EE DONUTS                       | 35.75        |
|         | 20220324SAV-C3/24/2022  |               | Hospitality / Food for CPR Class         | 43.82        |
|         | 20220324STA-L3/24/2022  |               | Hospitality / Coffee for Drill Training  | 115.00       |
|         | 20220325CIR-C3/25/2022  |               | Hospitality / Food for CPR Class         | 4.99         |
|         | 20220325GOO- 3/25/2022  |               | Hospitality / Donuts for CPR Class       | 36.00        |
|         | 20220325GOT-D3/25/2022  |               | Office-Software / Go To My PC            | 44.00        |
|         | 20220325SAV-C3/25/2022  |               | Hospitality / Food For CPR Class         | 23.51        |
|         | 20220325STA-B3/25/2022  |               | Office / Thumb Drive                     | 14.06        |
|         | 20220328AMA-L3/28/2022  |               | Office / Foam & Clear Cups               | 80.44        |
|         | 20220328MAR-L3/28/2022  |               | Eq#29 / Stickers For Boom Truck          | 16.90        |

**Chowchilla Water District**  
**Check Report**

Report Parameters:

Report Format: Invoice Level Detail

For Check Dates 4/21/2022 through 5/11/2022

For Vendors 00-0000000 through 99-ZZZZZZZ

**Bank Code: A**

| Check #  | Date             | Vendor Number | Vendor Name                              | Check Amount |
|----------|------------------|---------------|------------------------------------------|--------------|
| 20220328 | RAN-L3/28/2022   | 54222:        | 31 door handles                          | 235.74       |
| 20220329 | ASS-L3/29/2022   | B&G /         | Keys & Cylinders                         | 119.54       |
| 20220329 | CIR-L 3/29/2022  | 54207:        | UHMW 20 FT.                              | 91.36        |
| 20220329 | CON- 3/29/2022   |               | Office-Software / Constant Contact       | 20.00        |
| 20220331 | DUL-L3/31/2022   | 54232:        | 20-13 spray nozzles, bo                  | 387.87       |
| 20220331 | INF-D 3/31/2022  |               | Phone Conference for Board Meetings      | 12.34        |
| 20220331 | SIT-LB3/31/2022  |               | Office-Software / SiteGround - Hosting   | 179.88       |
| 202203   | SAV-CL 3/22/2022 |               | Hospitality / Lunch for CPR Class        | 320.72       |
| 20220401 | FLO-B4/1/2022    |               | Shop / Floor Mats                        | 287.27       |
| 20220402 | MSFT 4/2/2022    |               | Office-Software/OneDrive - 4 License     | 40.00        |
| 20220402 | STA-B4/2/2022    |               | Office / Wide Format Scanning            | 197.19       |
| 20220404 | AMA- 4/4/2022    |               | Office / USB Cable                       | 9.65         |
| 20220404 | SIR-B 4/4/2022   |               | Eq#10-17 / SiriusXM                      | 27.91        |
| 20220404 | TRUT 4/4/2022    |               | Office - Deed Research / TruthFinder     | 28.05        |
| 20220405 | AMA- 4/5/2022    |               | Canal / SS Wedge Anchor                  | 484.44       |
| 20220405 | AMA- 4/5/2022    |               | Canal / Flex Pipe Roller                 | 187.10       |
| 20220405 | AMA- 4/5/2022    |               | Canal / Pipe Paint Roller                | 65.20        |
| 20220405 | AMA- 4/5/2022    |               | Canal / SS Wedge Anchors                 | 593.70       |
| 20220405 | PPG-B4/5/2022    |               | Canal / Gray Paint                       | 59.24        |
| 20220407 | AMA- 4/7/2022    |               | Office / Cleaning Supplies               | 50.74        |
| 20220407 | AMA-L4/7/2022    |               | Eq / Parts for Grinders                  | 19.56        |
| 20220407 | AMA-L4/7/2022    | 54222:        | angle grinder parts                      | 79.36        |
| 20220407 | LEGA 4/7/2022    |               | Office-Software / Legal Zoom             | 7.99         |
| 20220407 | ZOO- 4/7/2022    |               | Office-Software / Zoom - Annual          | 149.90       |
| 20220407 | ZRC-B4/7/2022    |               | Canal / ZRC Cold Galvanizing             | 1,437.08     |
| 20220408 | AMA- 4/8/2022    |               | Office / Phone & Address Finder          | 21.74        |
| 20220409 | 8BEE 4/9/2022    |               | Office-Deed Research / BeenVerified      | 22.86        |
| 20220409 | DROP4/9/2022     |               | Office-Software / DropBox - DW           | 11.99        |
| 20220411 | ADOB4/11/2022    |               | Office-Software / Adobe - DW             | 14.99        |
| 20220411 | SAV-C4/11/2022   |               | Hospitality / Creamer                    | 8.68         |
| 20220412 | ACWA4/12/2022    |               | Membership/ Ultimate Water Supply Update | 360.00       |
| 20220412 | AMA-L4/12/2022   |               | Eq / Parts For Grinders                  | 12.18        |
| 20220412 | AMA-L4/12/2022   | 54222:        | parts for angle grinder                  | 68.10        |
| 20220412 | BIT-BT4/12/2022  |               | Travel/Lunch-ACWA Conference             | 17.91        |
| 20220413 | BIT-BT4/13/2022  |               | Travel / Lunch-ACWA Conference           | 14.46        |
| 20220413 | PIP-B 4/13/2022  |               | WM / 8" Flange Support Kit               | 371.98       |
| 20220414 | AMA-L4/14/2022   |               | Eq / Belt for Drill Press                | 35.88        |
| 20220414 | BON- 4/14/2022   |               | Travel / Lunch-ACWA Conference           | 8.37         |
| 20220414 | CHE-B4/14/2022   |               | Fuel for Eq# 10-17                       | 124.73       |
| 20220415 | HIL-B 4/15/2022  |               | Travel / Hotel-ACWA Conference           | 245.89       |
| 20220415 | HIL-B 4/15/2022  |               | Travel / Parking - ACWA Conference       | 27.00        |
| 20220416 | ADOB4/16/2022    |               | Office-Software / Adobe-6 License        | 101.94       |
| 20220418 | AMA-L4/18/2022   |               | Office / Trash Bags                      | 40.36        |
| 20220418 | AMA-L4/18/2022   |               | Office / Dish Soap                       | 6.47         |
| 20220418 | AMA-L4/18/2022   |               | Office / 3 Ring Divider Tabs             | 27.85        |

**Chowchilla Water District**  
**Check Report**

Report Parameters:

Report Format: Invoice Level Detail

For Check Dates 4/21/2022 through 5/11/2022

For Vendors 00-0000000 through 99-ZZZZZZZ

**Bank Code: A**

| Check #  | Date            | Vendor Number | Vendor Name                              | Check Amount |
|----------|-----------------|---------------|------------------------------------------|--------------|
| 20220418 | SAN-L4/18/2022  | 54222         | sandblasting nozzles                     | 208.59       |
| 20220419 | AMA- 4/19/2022  |               | Canal / Tear Away Lens for Clemco Helmet | 201.20       |
| 20220419 | JBT-L 4/19/2022 | 54207         | thickster gloves                         | 195.64       |
| 20220420 | AMA-L4/20/2022  |               | Canal / Marking Chalk                    | 17.36        |
| 20220420 | EFZX-4/20/2022  |               | Offcie-Software / EFax                   | 16.95        |
| 20220420 | ORDA-B4/20/2022 |               | Publication / Aquifer Storage Recovery   | 92.00        |
| 20220420 | SAV-L4/20/2022  |               | Hospitality / Creamer                    | 3.99         |
| 20220420 | SAV-L4/20/2022  |               | Hospitality / Refreshments for Board Mtg | 20.56        |
| 20220421 | MYS-L4/21/2022  |               | Safety Signs for Drill Press             | 55.11        |
| 030874   | 5/11/2022       | 00-A2009      | Abbey Door Service                       | 630.00       |
|          | Invoice #       | Date          | Invoice Comment                          | Inv. Amt.    |
|          | 14018           | 4/20/2022     | 56232: roll up door inspection           | 630.00       |
| 030875   | 5/11/2022       | 00-A2292      | ACWA-JPIA (HBA)                          | 30,483.08    |
|          | Invoice #       | Date          | Invoice Comment                          | Inv. Amt.    |
|          | 0686186         | 5/3/2022      | Employee Benefits / 2022 JUN             | 30,483.08    |
| 030876   | 5/11/2022       | 00-A2394      | Alview-Dairyland Union                   | 1,052.00     |
|          | Invoice #       | Date          | Invoice Comment                          | Inv. Amt.    |
|          | 2022-06         | 5/15/2022     | Directors Benefits-Mandala / 2022-JUN    | 1,052.00     |
| 030877   | 5/11/2022       | 00-A4261      | Aanonson Sprinkler Co., Inc.             | 5.93         |
|          | Invoice #       | Date          | Invoice Comment                          | Inv. Amt.    |
|          | 22-86763        | 4/22/2022     | WM/5" Flange Gasket                      | 5.93         |
| 030878   | 5/11/2022       | 00-B4891      | Blacks Irrigation Systems, Inc           | 3,219.65     |
|          | Invoice #       | Date          | Invoice Comment                          | Inv. Amt.    |
|          | 76188           | 4/27/2022     | Canal-DW / 48" x 48" Pipe                | 2,931.90     |
|          | 76195           | 4/29/2022     | WM/ 16" & 8" Pipe                        | 184.98       |
|          | 76197           | 4/29/2022     | WM/ 16" Pipe                             | 102.77       |

**Chowchilla Water District**  
**Check Report**

Report Parameters:

Report Format: Invoice Level Detail

For Check Dates 4/21/2022 through 5/11/2022

For Vendors 00-0000000 through 99-ZZZZZZZ

**Bank Code: A**

| Check # | Date             | Vendor Number | Vendor Name                            | Check Amount     |
|---------|------------------|---------------|----------------------------------------|------------------|
| 030879  | 5/11/2022        | 00-B5128      | Bureau of Reclamation                  | 519,392.50       |
|         | <u>Invoice #</u> | <u>Date</u>   | <u>Invoice Comment</u>                 | <u>Inv. Amt.</u> |
|         | 20220422-URF     | 4/22/2022     | URF Water Block 1 Tier 2               | 519,392.50       |
| 030880  | 5/11/2022        | 00-BSK2888    | BSK Associates                         | 827.00           |
|         | <u>Invoice #</u> | <u>Date</u>   | <u>Invoice Comment</u>                 | <u>Inv. Amt.</u> |
|         | AF07867          | 3/28/2022     | GSA / Water Quality Well Testing       | 189.00           |
|         | AF08126          | 3/30/2022     | GSA / Water Quality Well Testing       | 449.00           |
|         | AF08331          | 4/1/2022      | GSA / Water Quality Well Testing       | 126.00           |
|         | AF11201          | 5/3/2022      | GSA / Water Quality Well Testing       | 63.00            |
| 030881  | 5/11/2022        | 00-C3000      | Comcast                                | 539.75           |
|         | <u>Invoice #</u> | <u>Date</u>   | <u>Invoice Comment</u>                 | <u>Inv. Amt.</u> |
|         | 20220419         | 4/19/2022     | Phone-Internet Service thru 05/23/2022 | 539.75           |
| 030882  | 5/11/2022        | 00-C6630      | CALOLYMPIC SAFETY                      | 73.33            |
|         | <u>Invoice #</u> | <u>Date</u>   | <u>Invoice Comment</u>                 | <u>Inv. Amt.</u> |
|         | 398050-1         | 5/3/2022      | Safety / N95 Prefilter                 | 73.33            |
| 030883  | 5/11/2022        | 00-C8846      | Central Valley Concrete, Inc.          | 625.31           |
|         | <u>Invoice #</u> | <u>Date</u>   | <u>Invoice Comment</u>                 | <u>Inv. Amt.</u> |
|         | 193135           | 4/26/2022     | Canal/Concrete Blocks (5)              | 625.31           |
| 030884  | 5/11/2022        | 00-CIN0183    | Cintas Corporation #621                | 875.45           |
|         | <u>Invoice #</u> | <u>Date</u>   | <u>Invoice Comment</u>                 | <u>Inv. Amt.</u> |
|         | 4115831542       | 4/7/2022      | Uniform Service Through 04/07/2022     | 193.67           |
|         | 4116528668       | 4/14/2022     | Uniform Service Through 04/14/2022     | 200.90           |
|         | 4117197143       | 4/21/2022     | Uniform Service Through 04/21/2022     | 244.90           |
|         | 4117884065       | 4/28/2022     | Uniform Service Through 04/28/2022     | 235.98           |
| 030885  | 5/11/2022        | 00-D7770      | Divine Logic, Inc.                     | 340.95           |
|         | <u>Invoice #</u> | <u>Date</u>   | <u>Invoice Comment</u>                 | <u>Inv. Amt.</u> |
|         | 186645           | 4/18/2022     | Office-IT/Onsite- Firmware Update      | 220.95           |
|         | 186753           | 4/22/2022     | Office-IT/Server Monitoring            | 60.00            |
|         | 186941           | 4/29/2022     | Office-IT/Server Monitoring            | 60.00            |

**Chowchilla Water District**  
**Check Report**

Report Parameters:  
 Report Format: Invoice Level Detail  
 For Check Dates 4/21/2022 through 5/11/2022  
 For Vendors 00-0000000 through 99-ZZZZZZZ

**Bank Code: A**

| Check # | Date             | Vendor Number | Vendor Name                              | Check Amount     |
|---------|------------------|---------------|------------------------------------------|------------------|
| 030886  | 5/11/2022        | 00-DAV6107    | Davids Engineering, Inc.                 | 16,856.25        |
|         | <u>Invoice #</u> | <u>Date</u>   | <u>Invoice Comment</u>                   | <u>Inv. Amt.</u> |
|         | 1183.03-5124     | 4/25/2022     | Engineering/GSP Annual Report 2022       | 16,856.25        |
| 030887  | 5/11/2022        | 00-E2853      | esri-ENVIRONMENTAL SYSTEMS RESEARCH IN   | 1,200.00         |
|         | <u>Invoice #</u> | <u>Date</u>   | <u>Invoice Comment</u>                   | <u>Inv. Amt.</u> |
|         | 94245335         | 5/3/2022      | Office/ArcGIS Annual SoftwareMaintenance | 1,200.00         |
| 030888  | 5/11/2022        | 00-F6684      | Fresno Oxygen                            | 245.46           |
|         | <u>Invoice #</u> | <u>Date</u>   | <u>Invoice Comment</u>                   | <u>Inv. Amt.</u> |
|         | 62968698         | 4/21/2022     | Canal/Welding Gas                        | 245.46           |
| 030889  | 5/11/2022        | 00-F9000      | Farmers Hardware & Supply                | 124.09           |
|         | <u>Invoice #</u> | <u>Date</u>   | <u>Invoice Comment</u>                   | <u>Inv. Amt.</u> |
|         | OFF1F214908      | 4/29/2022     | EQ/31 mounting tape                      | 38.03            |
|         | OFF1F215094      | 4/29/2022     | EQ 63 - Ball valve; nipple               | 25.20            |
|         | OFF1F215272      | 4/29/2022     | B&G/Hose Coupler                         | 10.86            |
|         | OFF1F215900      | 4/21/2022     | Canal/Padlock                            | 26.09            |
|         | OFF1F216022      | 4/25/2022     | Canal/ Mag 2" Combo 1-1/2" SHKL          | 23.91            |
| 030890  | 5/11/2022        | 00-FW6305     | Friant Water Authority-SLDMWA            | 29,827.22        |
|         | <u>Invoice #</u> | <u>Date</u>   | <u>Invoice Comment</u>                   | <u>Inv. Amt.</u> |
|         | 115382           | 4/29/2022     | SLDMWA-O&M April                         | 28,589.44        |
|         | 115392           | 4/28/2022     | Water Supply Cord Monitoring             | 1,237.78         |
| 030891  | 5/11/2022        | 00-H1946      | Home Depot Credit Services               | 404.93           |
|         | <u>Invoice #</u> | <u>Date</u>   | <u>Invoice Comment</u>                   | <u>Inv. Amt.</u> |
|         | 3934618          | 4/4/2022      | Canal / Black Spray Paint                | 212.45           |
|         | 5020674          | 4/2/2022      | Canal / Paint and Supplies               | 192.48           |
| 030892  | 5/11/2022        | 00-H6620      | Holt of California (Inc.)                | 222.42           |
|         | <u>Invoice #</u> | <u>Date</u>   | <u>Invoice Comment</u>                   | <u>Inv. Amt.</u> |
|         | PS100224704      | 4/15/2022     | 54222: 50 air cleaner housing            | 222.42           |
| 030893  | 5/11/2022        | 00-K1000      | Klein DeNatale Goldner Attorneys At Law  | 7,356.50         |
|         | <u>Invoice #</u> | <u>Date</u>   | <u>Invoice Comment</u>                   | <u>Inv. Amt.</u> |
|         | 1191732          | 3/31/2022     | Legal Fees Through 03/18/2022            | 1,792.00         |



**Chowchilla Water District**  
**Check Report**

Report Parameters:

Report Format: Invoice Level Detail

For Check Dates 4/21/2022 through 5/11/2022

For Vendors 00-0000000 through 99-ZZZZZZZ

**Bank Code: A**

| Check # | Date             | Vendor Number | Vendor Name                         | Check Amount     |
|---------|------------------|---------------|-------------------------------------|------------------|
| 1193697 | 4/29/2022        |               | Legal Fees Through 04/20/2022       | 2,396.50         |
| 1193698 | 4/29/2022        |               | Joint Defense Expenses - 04/20/2022 | 3,168.00         |
| 030894  | 5/11/2022        | 00-K1501      | Kellogg's Supply                    | 117.86           |
|         | <u>Invoice #</u> | <u>Date</u>   | <u>Invoice Comment</u>              | <u>Inv. Amt.</u> |
|         | 30942            | 4/26/2022     | Canal/Paint; welding cap            | 117.86           |
| 030895  | 5/11/2022        | 00-L1408      | Lowe's Business Account             | 2,254.96         |
|         | <u>Invoice #</u> | <u>Date</u>   | <u>Invoice Comment</u>              | <u>Inv. Amt.</u> |
|         | 01728            | 3/31/2022     | Canal / Penetrant Lubricant         | 106.74           |
|         | 01839            | 4/15/2022     | Canal / 6ft Ladder                  | 82.26            |
|         | 08627            | 4/12/2022     | Canal / DeWalt Angle Grinder        | 132.61           |
|         | 70112            | 3/29/2022     | B&G/Deadbolt                        | 33.41            |
|         | 74259            | 4/13/2022     | Tools/metric comb wrenches          | 296.44           |
|         | 94056            | 4/18/2022     | Canal / Paint                       | 974.86           |
|         | 96561            | 3/31/2022     | Canal/(8)Shovels;(1)Spade;pip       | 628.64           |
| 030896  | 5/11/2022        | 00-L1615      | L&L Electrical                      | 4,459.05         |
|         | <u>Invoice #</u> | <u>Date</u>   | <u>Invoice Comment</u>              | <u>Inv. Amt.</u> |
|         | 2022-637         | 4/27/2022     | Annual SCADA Licens                 | 4,459.05         |
| 030897  | 5/11/2022        | 00-LAW7664    | Lawson Products                     | 1,434.40         |
|         | <u>Invoice #</u> | <u>Date</u>   | <u>Invoice Comment</u>              | <u>Inv. Amt.</u> |
|         | 93049495611      | 4/21/2022     | 54207: NUTS, BOLTS, BITS, CONN      | 1,357.73         |
|         | 9309508930       | 4/26/2022     | 54207: butt connectors              | 76.67            |
| 030898  | 5/11/2022        | 00-M0526      | Moore Quality Galvanizing L.P.      | 270.63           |
|         | <u>Invoice #</u> | <u>Date</u>   | <u>Invoice Comment</u>              | <u>Inv. Amt.</u> |
|         | 160230           | 4/19/2022     | Custom/Harris Gate                  | 270.63           |
| 030899  | 5/11/2022        | 00-M7228      | Midland Tractor                     | 47.91            |
|         | <u>Invoice #</u> | <u>Date</u>   | <u>Invoice Comment</u>              | <u>Inv. Amt.</u> |
|         | W03127           | 5/3/2022      | Eq#30-18 / Handle                   | 47.91            |
| 030900  | 5/11/2022        | 00-M7431      | Merced County Department of Ag      | 1,380.00         |
|         | <u>Invoice #</u> | <u>Date</u>   | <u>Invoice Comment</u>              | <u>Inv. Amt.</u> |
|         | 12972            | 4/28/2022     | Canal/Diphacinone                   | 1,380.00         |

**Chowchilla Water District  
Check Report**

Report Parameters:

Report Format: Invoice Level Detail

For Check Dates 4/21/2022 through 5/11/2022

For Vendors 00-0000000 through 99-ZZZZZZZ

**Bank Code: A**

| Check # | Date             | Vendor Number | Vendor Name                          | Check Amount     |
|---------|------------------|---------------|--------------------------------------|------------------|
| 030901  | 5/11/2022        | 00-M7521      | Mid-Valley Pipe & Steel, Inc.        | 380.08           |
|         | <u>Invoice #</u> | <u>Date</u>   | <u>Invoice Comment</u>               | <u>Inv. Amt.</u> |
|         | 50305            | 4/29/2022     | WM/ 2 7/8" x 7' Fence Post           | 380.08           |
| 030902  | 5/11/2022        | 00-M7724      | MADERA COUNTY RECORDER OFFICE        | 720.00           |
|         | <u>Invoice #</u> | <u>Date</u>   | <u>Invoice Comment</u>               | <u>Inv. Amt.</u> |
|         | 20220427-RC      | 4/27/2022     | 36 Redemption Certificates           | 720.00           |
| 030903  | 5/11/2022        | 00-MC3514     | Madera Chowchilla Water & Powe       | 33,555.61        |
|         | <u>Invoice #</u> | <u>Date</u>   | <u>Invoice Comment</u>               | <u>Inv. Amt.</u> |
|         | 417              | 4/28/2022     | CFF #417/ O&M for 4-Sites & MC - MAR | 33,555.61        |
| 030904  | 5/11/2022        | 00-O3633      | The Office City                      | 247.73           |
|         | <u>Invoice #</u> | <u>Date</u>   | <u>Invoice Comment</u>               | <u>Inv. Amt.</u> |
|         | 1742088          | 4/26/2022     | Office/Binders                       | 247.73           |
| 030905  | 5/11/2022        | 00-ORE9031    | O'Reilly Auto Parts                  | 1,372.82         |
|         | <u>Invoice #</u> | <u>Date</u>   | <u>Invoice Comment</u>               | <u>Inv. Amt.</u> |
|         | 2880-314289      | 3/31/2022     | 54222: 31, 3,, 9 new batteries       | 670.52           |
|         | 2880-314291      | 3/31/2022     | 54222: oil filter, air filters       | 409.44           |
|         | 2880-314293      | 3/31/2022     | 54222: 10-17, 8-19, brake pads       | 251.47           |
|         | 2880-315804      | 4/29/2022     | 54222: 45 idle air control val       | 54.57            |
|         | EB17618392       | 4/21/2022     | EQ / Earn Back Credit - MAR          | -13.18           |
| 030906  | 5/11/2022        | 00-P5000S     | Pacific Gas & Electric Company       | 168.91           |
|         | <u>Invoice #</u> | <u>Date</u>   | <u>Invoice Comment</u>               | <u>Inv. Amt.</u> |
|         | 20020418         | 4/18/2022     | Pump/SCADA Electrical- MAR           | 168.91           |
| 030907  | 5/11/2022        | 00-P6121      | Platt                                | 29.78            |
|         | <u>Invoice #</u> | <u>Date</u>   | <u>Invoice Comment</u>               | <u>Inv. Amt.</u> |
|         | 1Z13056          | 4/15/2022     | WM/Cord Connector                    | 29.78            |
| 030908  | 5/11/2022        | 00-P8999      | ParcelQuest                          | 2,399.00         |
|         | <u>Invoice #</u> | <u>Date</u>   | <u>Invoice Comment</u>               | <u>Inv. Amt.</u> |
|         | 7808-4-2022      | 4/29/2022     | Deed Copy Service through MAY 2023   | 2,399.00         |
| 030909  | 5/11/2022        | 00-R&S9670    | R&S Erection Tri-County, INC.        | 1,045.00         |

**Chowchilla Water District**  
**Check Report**

Report Parameters:

Report Format: Invoice Level Detail

For Check Dates 4/21/2022 through 5/11/2022

For Vendors 00-0000000 through 99-ZZZZZZZ

**Bank Code: A**

| Check # | Date             | Vendor Number | Vendor Name                         | Check Amount     |
|---------|------------------|---------------|-------------------------------------|------------------|
|         | <u>Invoice #</u> | <u>Date</u>   | <u>Invoice Comment</u>              | <u>Inv. Amt.</u> |
|         | 723151           | 3/31/2022     | 56232: roll up door repair          | 295.00           |
|         | 732751           | 4/18/2022     | 56232: roll up door service pm      | 750.00           |
| 030910  | 5/11/2022        | 00-S4446      | S & W Parts Inc.                    | 29.01            |
|         | <u>Invoice #</u> | <u>Date</u>   | <u>Invoice Comment</u>              | <u>Inv. Amt.</u> |
|         | 108730           | 4/28/2022     | EQ/gaskets & brush                  | 29.01            |
| 030911  | 5/11/2022        | 00-S4658      | Schoettler Tire, Inc.               | 64.35            |
|         | <u>Invoice #</u> | <u>Date</u>   | <u>Invoice Comment</u>              | <u>Inv. Amt.</u> |
|         | 158996           | 4/28/2022     | 54222: 43-18 tire repair            | 64.35            |
| 030912  | 5/11/2022        | 00-S7505      | Spriggs Inc.                        | 328.03           |
|         | <u>Invoice #</u> | <u>Date</u>   | <u>Invoice Comment</u>              | <u>Inv. Amt.</u> |
|         | 162939           | 5/1/2022      | Office/Copier Services-APR          | 328.03           |
| 030913  | 5/11/2022        | 00-T1207      | Technoflo Systems                   | 5,520.73         |
|         | <u>Invoice #</u> | <u>Date</u>   | <u>Invoice Comment</u>              | <u>Inv. Amt.</u> |
|         | 35115            | 4/21/2022     | H2O-Meas/8" Mag Meter/Spare         | 2,338.56         |
|         | 35116            | 4/21/2022     | H2O-Meas/6" Mag Meter/Spare         | 2,039.28         |
|         | 35197            | 4/27/2022     | H2O-Meas/Califa 13/Berenda 21       | 1,142.89         |
| 030914  | 5/11/2022        | 00-T4952      | TF Tire & Service                   | 2,346.93         |
|         | <u>Invoice #</u> | <u>Date</u>   | <u>Invoice Comment</u>              | <u>Inv. Amt.</u> |
|         | 349592           | 4/21/2022     | 54222: 12-18 new tires              | 1,527.17         |
|         | CH-349353        | 3/29/2022     | 54222: 48-19 tire repair            | 309.87           |
|         | CH-349461        | 4/11/2022     | 54222: 21 new tires                 | 509.89           |
| 030915  | 5/11/2022        | 00-U2438      | Upton, Kole M.                      | 705.33           |
|         | <u>Invoice #</u> | <u>Date</u>   | <u>Invoice Comment</u>              | <u>Inv. Amt.</u> |
|         | 2022-05          | 5/1/2022      | Directors Benefits-Upton / 2022 MAY | 705.33           |
| 030916  | 5/11/2022        | 00-V3900      | Valley Iron, Inc.                   | 2,958.11         |
|         | <u>Invoice #</u> | <u>Date</u>   | <u>Invoice Comment</u>              | <u>Inv. Amt.</u> |
|         | 2150280          | 4/22/2022     | Canal/4" Flange I Beam              | 2,533.45         |
|         | 2151854          | 4/27/2022     | Canal/ 8" Flange & Gasket           | 424.66           |
| 030917  | 5/11/2022        | 00-VAN3421    | VAN DE POL                          | 2,384.00         |

**Chowchilla Water District**  
**Check Report**

Report Parameters:

Report Format: Invoice Level Detail

For Check Dates 4/21/2022 through 5/11/2022

For Vendors 00-0000000 through 99-ZZZZZZZ

**Bank Code: A**

| Check #                       | Date             | Vendor Number | Vendor Name                             | Check Amount      |
|-------------------------------|------------------|---------------|-----------------------------------------|-------------------|
|                               | <u>Invoice #</u> | <u>Date</u>   | <u>Invoice Comment</u>                  | <u>Inv. Amt.</u>  |
|                               | CL25399          | 4/30/2022     | DSL 179.456g / GAS 319.284g             | 2,384.00          |
| 030918                        | 5/11/2022        | 00-VER0204    | Verizon Wireless                        | 1,285.07          |
|                               | <u>Invoice #</u> | <u>Date</u>   | <u>Invoice Comment</u>                  | <u>Inv. Amt.</u>  |
|                               | 9904511743       | 4/19/2022     | Mobile Phone Service Through 04/19/2022 | 1,285.07          |
| 030919                        | 5/11/2022        | 00-W9269      | Western Ag Irrigation, Inc.             | 5,420.99          |
|                               | <u>Invoice #</u> | <u>Date</u>   | <u>Invoice Comment</u>                  | <u>Inv. Amt.</u>  |
|                               | 131061           | 4/26/2022     | Canal/60" Corrugated Pipe               | 3,218.81          |
|                               | 131088           | 4/29/2022     | Canal/Dry Wells                         | 1,715.08          |
|                               | 131234           | 4/18/2022     | Custom/Harris Gate Structure            | 487.10            |
| 409422                        | 4/29/2022        | 00-N4224      | Nationwide Trust Co. FSB                | 3,918.91          |
|                               | <u>Invoice #</u> | <u>Date</u>   | <u>Invoice Comment</u>                  | <u>Inv. Amt.</u>  |
|                               | 04302022         | 4/29/2022     | April 2022 ER Pension Contrib           | 3,918.91          |
| 456114                        | 4/29/2022        | 00-E5616      | Employment Development Dept.            | 1,500.59          |
|                               | <u>Invoice #</u> | <u>Date</u>   | <u>Invoice Comment</u>                  | <u>Inv. Amt.</u>  |
|                               | 0-144-326-240    | 4/29/2022     | State Income Tax PE: 04/24/2022         | 1,500.59          |
| 457114                        | 4/27/2022        | 00-N4224      | Nationwide Trust Co. FSB                | 324.53            |
|                               | <u>Invoice #</u> | <u>Date</u>   | <u>Invoice Comment</u>                  | <u>Inv. Amt.</u>  |
|                               | 04/24/2022       | 4/27/2022     | 457 EE Contrib PE: 04/24/2022           | 324.53            |
| 941114                        | 4/29/2022        | 00-I3201      | Internal Revenue Service                | 11,860.89         |
|                               | <u>Invoice #</u> | <u>Date</u>   | <u>Invoice Comment</u>                  | <u>Inv. Amt.</u>  |
|                               | 80779541         | 4/29/2022     | Fed Tax w/Hold PE: 04/24/2022           | 11,860.89         |
| <b>Total For Bank Code A:</b> |                  |               |                                         | <b>722,572.47</b> |

2022  
BUDGETED  
VS.  
ACTUAL INCOME  
AND EXPENSE

This Page is Blank Intentionally

**Chowchilla Water District**  
**Income Statement for Period Ending**  
**April 30, 2022**

|                                     | Current Period |                | Year to Date     |                  | ANNUAL BUDGET    | Variance           |
|-------------------------------------|----------------|----------------|------------------|------------------|------------------|--------------------|
|                                     | ACTUAL         | BUDGET         | ACTUAL           | BUDGET           |                  |                    |
| <b>REVENUE</b>                      |                |                |                  |                  |                  |                    |
| <b>Water Sales</b>                  |                |                |                  |                  |                  |                    |
| Irrigation                          | 0              | 0              | 167,290          | 0                | 3,405,200        | (3,237,910)        |
| Water for Resale                    | 0              | 0              | 0                | 0                | 990,000          | (990,000)          |
| <b>Total Water Sales</b>            | <b>0</b>       | <b>0</b>       | <b>167,290</b>   | <b>0</b>         | <b>4,395,200</b> | <b>(4,227,910)</b> |
| <b>Assessments</b>                  |                |                |                  |                  |                  |                    |
| Assessment Revenue                  | 0              | 0              | 0                | 0                | 2,195,174        | (2,195,174)        |
| Capital Repayment Assessment        | 0              | 0              | 0                | 0                | 1,707,342        | (1,707,342)        |
| Supplemental Assessm                | 0              | 0              | 0                | 0                | 1,241,703        | (1,241,703)        |
| <b>Total Assessments:</b>           | <b>0</b>       | <b>0</b>       | <b>0</b>         | <b>0</b>         | <b>5,144,219</b> | <b>(5,144,219)</b> |
| <b>Taxes</b>                        |                |                |                  |                  |                  |                    |
| Merced County                       | 0              | 0              | 0                | 0                | 200,000          | (200,000)          |
| <b>Total Taxes:</b>                 | <b>0</b>       | <b>0</b>       | <b>0</b>         | <b>0</b>         | <b>200,000</b>   | <b>(200,000)</b>   |
| <b>Custom Work</b>                  |                |                |                  |                  |                  |                    |
| Custom Non-Meter                    | 0              | 417            | 0                | 1,667            | 5,000            | (5,000)            |
| Custom Work-Meter                   | 0              | 500            | 0                | 2,000            | 6,000            | (6,000)            |
| <b>Total Custom Work:</b>           | <b>0</b>       | <b>917</b>     | <b>0</b>         | <b>3,667</b>     | <b>11,000</b>    | <b>(11,000)</b>    |
| <b>Penalties</b>                    |                |                |                  |                  |                  |                    |
| Assessment Penalties                | 0              | 0              | 11,275           | 12,000           | 12,000           | (725)              |
| <b>Total Penalties:</b>             | <b>0</b>       | <b>0</b>       | <b>11,275</b>    | <b>12,000</b>    | <b>12,000</b>    | <b>(725)</b>       |
| <b>Total Revenue:</b>               | <b>0</b>       | <b>917</b>     | <b>178,565</b>   | <b>15,667</b>    | <b>9,762,419</b> | <b>(9,583,854)</b> |
| <b>Gross Profit</b>                 | <b>0</b>       | <b>917</b>     | <b>178,565</b>   | <b>15,667</b>    | <b>9,762,419</b> | <b>(9,583,854)</b> |
| <b>EXPENSES</b>                     |                |                |                  |                  |                  |                    |
| <b>Source of Supply</b>             |                |                |                  |                  |                  |                    |
| Water Purchase - Friant Water Cls 1 | 0              | 0              | 216,227          | 216,227          | 237,502          | (21,275)           |
| Recovered /Recap/Recirc Water       | 0              | 57,500         | 27,405           | 84,905           | 486,684          | (459,279)          |
| Unreleased Restoration Flows: URF   | 519,393        | 519,393        | 519,393          | 519,393          | 1,371,420        | (852,028)          |
| O & M Buchanan Dam                  | 0              | 0              | 470,280          | 470,280          | 940,560          | (470,280)          |
| Restoration - Friant                | 0              | 0              | 93,052           | 0                | 120,588          | (27,536)           |
| Surcharge - Friant                  | 0              | 0              | 58,002           | 0                | 75,166           | (17,164)           |
| O & M San Luis/Mendota              | 29,827         | 150,000        | 329,152          | 600,000          | 1,800,000        | (1,470,848)        |
| O & M Madera Canal                  | 15,008         | 48,323         | 57,208           | 193,293          | 579,880          | (522,672)          |
| B of A Capital Obligation Loan      | 0              | 0              | 0                | 0                | 1,667,792        | (1,667,792)        |
| Water Rights Fees                   | 25,256         | 25,278         | 101,026          | 101,112          | 303,337          | (202,311)          |
| Trinity PUD Assessme                | 0              | 0              | 3,043            | 3,043            | 5,211            | (2,168)            |
| <b>Total Source of Supply:</b>      | <b>589,484</b> | <b>800,494</b> | <b>1,874,786</b> | <b>2,188,253</b> | <b>7,588,140</b> | <b>(5,713,354)</b> |
| <b>Capital Expenditures</b>         |                |                |                  |                  |                  |                    |
| Capital Expense- Heavy Equipment    | 600            | 0              | 407,026          | 400,000          | 400,000          | 7,026              |
| Capital Exp-Tools/Safety            | 0              | 1,500          | 0                | 1,500            | 6,500            | (6,500)            |
| Capital Exp-Office                  | 0              | 2,000          | 0                | 2,000            | 5,000            | (5,000)            |
| Cap Exp - Road 19 Pond - Barrigan   | 0              | 0              | 0                | 0                | 5,163            | (5,163)            |
| Cap Exp - Pond - Woods              | 0              | 0              | 9,837            | 9,837            | 9,837            | 0                  |
| Cap Exp- Pond:Acconero              | 0              | 4,018          | 6,982            | 15,000           | 15,000           | (8,018)            |
| <b>Total Capital Expenditures:</b>  | <b>600</b>     | <b>7,518</b>   | <b>423,845</b>   | <b>428,337</b>   | <b>441,500</b>   | <b>(17,655)</b>    |

**Chowchilla Water District**  
**Income Statement for Period Ending**  
**April 30, 2022**

|                                             | Current Period |                | Year to Date   |                | ANNUAL BUDGET    | Variance           |
|---------------------------------------------|----------------|----------------|----------------|----------------|------------------|--------------------|
|                                             | ACTUAL         | BUDGET         | ACTUAL         | BUDGET         |                  |                    |
| <b>Transmission and Distribution</b>        |                |                |                |                |                  |                    |
| Maintenance Salaries                        | 37,137         | 37,137         | 135,163        | 135,163        | 450,000          | (314,837)          |
| Maintenance P/R Taxes                       | 2,639          | 2,639          | 11,583         | 11,583         | 36,000           | (24,417)           |
| Maintenance W/C Insurance                   | 1,541          | 1,667          | 5,993          | 6,767          | 20,100           | (14,107)           |
| Maintenance Employee Benefits               | 18,497         | 18,497         | 73,442         | 73,442         | 206,500          | (133,058)          |
| Reservoir Expense                           | 0              | 5,600          | 5,050          | 5,600          | 5,600            | (550)              |
| Canal Expense                               | 25,074         | 9,696          | 53,863         | 38,485         | 172,000          | (118,137)          |
| Canal Expense:SCADA                         | 0              | 2,500          | 6,851          | 10,000         | 30,000           | (23,149)           |
| Canal Expense-Drywells                      | 4,647          | 0              | 9,615          | 0              | 0                | 9,615              |
| Pipeline Expense                            | (33)           | 4,167          | 28,051         | 16,667         | 50,000           | (21,949)           |
| Pipeline Cost Sharing                       | 0              | 583            | 0              | 2,333          | 7,000            | (7,000)            |
| Equipment Expense                           | 4,276          | 7,083          | 26,195         | 28,333         | 85,000           | (58,805)           |
| Tool Purchases                              | 296            | 358            | 2,124          | 1,138          | 4,000            | (1,876)            |
| Weed Control Expense                        | 9,116          | 16,667         | 51,443         | 66,667         | 200,000          | (148,557)          |
| Water Measurement Expense                   | 32,632         | 32,260         | 59,802         | 59,430         | 140,000          | (80,198)           |
| Custom Work Exp - METERS                    | 0              | 1,167          | 0              | 4,667          | 14,000           | (14,000)           |
| Custom Work Exp - NON Meter                 | 0              | 1,417          | 0              | 3,667          | 15,000           | (15,000)           |
| Property Damage - Claims                    | 0              | 166            | 0              | 665            | 2,000            | (2,000)            |
| Rent                                        | 0              | 0              | 0              | 0              | 1                | (1)                |
| Engineering Expense                         | 0              | 4,167          | 2,448          | 16,667         | 50,000           | (47,552)           |
| GSA - Groundwater Management                | 12,537         | 16,667         | 45,751         | 66,667         | 200,000          | (154,249)          |
| Fuel & Lubrication Expense                  | 8,031          | 9,500          | 25,473         | 38,000         | 114,000          | (88,527)           |
| Pump Repair Expense                         | 0              | 0              | 0              | 0              | 25,000           | (25,000)           |
| Pumping Expense                             | 320            | 2,083          | 1,868          | 8,333          | 25,000           | (23,132)           |
| Pumping Expense (SCADA)                     | 169            | 1,500          | 2,196          | 6,000          | 18,000           | (15,804)           |
| Safety Expense                              | 686            | 833            | 3,882          | 3,333          | 10,000           | (6,118)            |
| Shop Supplies and Expense                   | 287            | 417            | 1,045          | 1,667          | 5,000            | (3,955)            |
| Uniform Expense                             | 875            | 1,000          | 3,752          | 4,000          | 12,500           | (8,748)            |
| Shop Utilities                              | 0              | 500            | 1,654          | 2,000          | 6,000            | (4,346)            |
| Other - Distribution                        | 0              | 250            | 450            | 1,000          | 3,000            | (2,550)            |
| Maintenance Profit Sharing Contributions    | 1,556          | 3,425          | 11,693         | 13,700         | 41,100           | (29,407)           |
| <b>Total Transmission and Distribution:</b> | <b>160,285</b> | <b>181,946</b> | <b>569,389</b> | <b>625,974</b> | <b>1,946,801</b> | <b>(1,377,412)</b> |
| <b>Customer Accounts</b>                    |                |                |                |                |                  |                    |
| Ditchtender Salaries                        | 21,117         | 35,375         | 94,754         | 100,550        | 288,000          | (193,246)          |
| Ditchtender P/R Taxes                       | 1,690          | 1,735          | 7,806          | 8,029          | 23,000           | (15,194)           |
| Ditchtender W/C Insurance                   | 987            | 1,083          | 4,069          | 4,333          | 13,000           | (8,931)            |
| Ditchtender Employee Benefits               | 10,985         | 10,833         | 43,584         | 43,333         | 130,000          | (86,416)           |
| Ditchtender Profit Sharing Contributions    | 1,032          | 2,333          | 8,726          | 9,333          | 28,000           | (19,274)           |
| <b>Total Customer Accounts:</b>             | <b>35,811</b>  | <b>51,361</b>  | <b>158,938</b> | <b>165,579</b> | <b>482,000</b>   | <b>(323,062)</b>   |
| <b>Administrative and General</b>           |                |                |                |                |                  |                    |
| Administration Salaries                     | 37,138         | 37,138         | 154,352        | 154,352        | 425,000          | (270,648)          |
| Administration P/R Taxes                    | 2,859          | 3,843          | 12,585         | 11,069         | 31,550           | (18,965)           |
| Administration W/C Insurance                | 215            | 208            | 860            | 833            | 2,500            | (1,640)            |
| Admin Employee Benefits                     | 10,398         | 10,398         | 41,152         | 41,152         | 105,000          | (63,848)           |
| Mileage Expense                             | 0              | 84             | 0              | 335            | 1,000            | (1,000)            |
| Travel Expense                              | 0              | 417            | 0              | 1,667          | 5,000            | (5,000)            |
| Travel - Training & Education               | 0              | 0              | 1,583          | 250            | 5,000            | (3,417)            |
| Travel - Training & Education (Out of Town) | 0              | 417            | 782            | 1,667          | 5,000            | (4,218)            |
| Travel - Conferences                        | 314            | 667            | 1,422          | 2,667          | 8,000            | (6,578)            |
| Travel - Events                             | 0              | 167            | 0              | 667            | 2,000            | (2,000)            |
| Reports & Publications Expense              | 248            | 160            | 382            | 300            | 500              | (118)              |
| Membership Fees and Dues                    | 2,241          | 2,083          | 7,564          | 8,333          | 25,000           | (17,436)           |
| Membership Fees Madera-Chowchilla Basin     | 0              | 100            | 0              | 400            | 1,200            | (1,200)            |
| Membership Fees and Dues :FWA               | 0              | 0              | 57,216         | 58,000         | 230,000          | (172,784)          |
| Office Supplies and Expense                 | 690            | 700            | 1,817          | 1,900          | 4,000            | (2,183)            |
| Office Expense - Supplies                   | 765            | 1,667          | 6,800          | 6,667          | 20,000           | (13,200)           |
| Office Expense - Copier                     | 328            | 333            | 1,223          | 1,333          | 4,000            | (2,777)            |
| Office Expense - Postage                    | 0              | 750            | 1,363          | 3,000          | 9,000            | (7,637)            |
| Office Expense - IT Support                 | 2,341          | 2,083          | 9,061          | 8,333          | 25,000           | (15,939)           |
| Office Expense - Computer EQ/Software       | 588            | 917            | 2,202          | 3,667          | 11,000           | (8,798)            |
| Office Expense - Deeds & Collection         | 356            | 375            | 1,282          | 1,500          | 4,500            | (3,218)            |
| Office Expense - Education                  | 0              | 83             | 49             | 333            | 1,000            | (951)              |
| Buildings & Grounds                         | 4,717          | 125            | 7,360          | 500            | 1,500            | 5,860              |
| Legal Expense                               | 4,189          | 4,167          | 6,229          | 16,667         | 50,000           | (43,772)           |
| Legal Expense-Joint Defense Agreement       | 4,388          | 8,333          | 10,892         | 33,333         | 100,000          | (89,108)           |



**Chowchilla Water District**  
**Income Statement for Period Ending**  
**April 30, 2022**

|                                             | Current Period   |                    | Year to Date       |                    | ANNUAL BUDGET      | Variance           |
|---------------------------------------------|------------------|--------------------|--------------------|--------------------|--------------------|--------------------|
|                                             | ACTUAL           | BUDGET             | ACTUAL             | BUDGET             |                    |                    |
| Auditing Expense                            | 0                | 0                  | 0                  | 0                  | 10,500             | (10,500)           |
| Advertising - General                       | 0                | 1,000              | 0                  | 1,000              | 1,000              | (1,000)            |
| Legal Advertising Expense                   | 0                | 0                  | 7,050              | 7,325              | 7,500              | (450)              |
| Miscellaneous Exp - Admin                   | 0                | 167                | 0                  | 667                | 2,000              | (2,000)            |
| Insurance Expense                           | 4,032            | 4,083              | 16,128             | 16,333             | 49,000             | (32,872)           |
| Profit Sharing Administrative Costs         | 0                | 0                  | 0                  | 0                  | 2,000              | (2,000)            |
| Administration Profit Sharing Contributions | 1,331            | 2,833              | 11,716             | 11,333             | 34,000             | (22,284)           |
| Directors' Per Diem                         | 0                | 0                  | 165                | 450                | 1,800              | (1,635)            |
| Directors' P/R Taxes                        | 0                | 0                  | 13                 | 35                 | 138                | (125)              |
| Directors' W/C Insurance                    | 0                | 3                  | 1                  | 3                  | 10                 | (9)                |
| Directors' Benefits                         | 5,321            | 5,667              | 21,285             | 22,667             | 68,000             | (46,715)           |
| Hospitality Expense                         | 0                | 83                 | 82                 | 333                | 1,000              | (918)              |
| Hospitality - Lunch (BT)                    | 0                | 83                 | 0                  | 333                | 1,000              | (1,000)            |
| Hospitality - Lunch (DW)                    | 0                | 83                 | 0                  | 333                | 1,000              | (1,000)            |
| Hospitality - Refreshments (Directors)      | 21               | 83                 | 116                | 333                | 1,000              | (884)              |
| Hospitality - Refreshments (Employees)      | 645              | 167                | 1,054              | 667                | 2,000              | (946)              |
| Hospitality - Holidays                      | 0                | 0                  | 0                  | 0                  | 8,000              | (8,000)            |
| Hospitality Expense-Education               | 0                | 0                  | 0                  | 250                | 1,000              | (1,000)            |
| Telephone Expense                           | 2,377            | 2,333              | 7,835              | 9,333              | 28,000             | (20,165)           |
| Office Utilities                            | 0                | 1,458              | 3,883              | 5,833              | 17,500             | (13,617)           |
| <b>Total Administrative and General:</b>    | <b>85,500</b>    | <b>93,258</b>      | <b>395,500</b>     | <b>436,152</b>     | <b>1,313,198</b>   | <b>(917,698)</b>   |
| <b>Total Expenses</b>                       | <b>871,681</b>   | <b>1,134,576</b>   | <b>3,422,458</b>   | <b>3,844,295</b>   | <b>11,771,639</b>  | <b>(8,349,181)</b> |
| <b>NET INCOME FROM OPERATIONS</b>           | <b>(871,681)</b> | <b>(1,133,659)</b> | <b>(3,243,893)</b> | <b>(3,828,628)</b> | <b>(2,009,220)</b> | <b>(1,234,673)</b> |
| <b>Non-Operating Revenue</b>                |                  |                    |                    |                    |                    |                    |
| Investment Interest                         | 2,056            | 917                | 3,564              | 3,667              | 11,000             | (7,436)            |
| Crop Water Interest                         | 369              | 917                | 1,754              | 3,667              | 11,000             | (9,246)            |
| Assessment Interest                         | 1,247            | 1,417              | 3,767              | 5,667              | 17,000             | (13,233)           |
| Annexation Revenue                          | 0                | 0                  | 0                  | 0                  | 3,000              | (3,000)            |
| Miscellaneous Revenue                       | 18,525           | 15,000             | 31,788             | 28,263             | 61,000             | (29,213)           |
| FPA Revenue                                 | 0                | 0                  | 221,397            | 221,397            | 400,000            | (178,603)          |
| Cash Over/Short (Loss)                      | 0                | 0                  | 19                 | 0                  | 0                  | 19                 |
| Refunds                                     | 26,358           | 0                  | 26,358             | 0                  | 0                  | 26,358             |
| Other Income - Reserves Transfer            | 0                | 0                  | 0                  | 0                  | 2,000,000          | (2,000,000)        |
| <b>Total Non-Operating Revenue:</b>         | <b>49,690</b>    | <b>18,250</b>      | <b>289,851</b>     | <b>262,659</b>     | <b>2,503,000</b>   | <b>(2,213,149)</b> |
| <b>Non-Operating Expenses</b>               |                  |                    |                    |                    |                    |                    |
| MCWPA Three Sites                           | 11,859           | 18,224             | 46,030             | 72,896             | 218,688            | (172,658)          |
| MCWPA Site 980                              | 6,689            | 7,068              | 19,539             | 28,271             | 84,813             | (65,274)           |
| <b>Total Non-Operating Expenses:</b>        | <b>18,547</b>    | <b>25,292</b>      | <b>65,569</b>      | <b>101,167</b>     | <b>303,501</b>     | <b>(237,932)</b>   |
| <b>Total Other Revenue and Expense:</b>     | <b>31,142</b>    | <b>(7,042)</b>     | <b>224,282</b>     | <b>161,492</b>     | <b>2,199,499</b>   | <b>(1,975,217)</b> |
| <b>Earnings Before Income Taxes</b>         | <b>(840,538)</b> | <b>(1,140,701)</b> | <b>(3,019,611)</b> | <b>(3,667,136)</b> | <b>190,279</b>     | <b>(3,209,890)</b> |
| <b>Net Income (Loss):</b>                   | <b>(840,538)</b> | <b>(1,140,701)</b> | <b>(3,019,611)</b> | <b>(3,667,136)</b> | <b>190,279</b>     | <b>(3,209,890)</b> |

**Chowchilla Water District**  
**Income Statement for Period Ending**  
**April 30, 2022**

|                        | Current Period |             | Year to Date |             | ANNUAL<br>BUDGET | Variance     |
|------------------------|----------------|-------------|--------------|-------------|------------------|--------------|
|                        | ACTUAL         | BUDGET      | ACTUAL       | BUDGET      |                  |              |
| Income Operations      | 0              | 917         | 178,565      | 15,667      | 9,762,419        | (9,583,854)  |
| Income Non-Operation   | 49,690         | 18,250      | 289,851      | 262,659     | 2,503,000        | (2,213,149)  |
| Total Income           | 49,690         | 19,167      | 468,416      | 278,326     | 12,265,419       | (11,797,003) |
| Expenses Operations    | 871,681        | 1,134,576   | 3,422,458    | 3,844,295   | 11,771,639       | (8,349,181)  |
| Expenses Non-Operation | 18,547         | 25,292      | 65,569       | 101,167     | 303,501          | (237,932)    |
| Total Expenses         | 890,228        | 1,159,867   | 3,488,027    | 3,945,462   | 12,075,140       | (8,587,113)  |
| B of A Debt Service    | 0              | 0           | 0            | 0           | 1,667,792        | (1,667,792)  |
| Expense Capital        | 600            | 7,518       | 423,845      | 428,337     | 441,500          | (17,655)     |
| Net Expenses           | 600            | 7,518       | 423,845      | 428,337     | 2,109,292        | (1,685,447)  |
| Net Income             | (840,538)      | (1,140,701) | (3,019,611)  | (3,667,136) | 190,279          | (3,209,890)  |
| B of A Debt Service    | 0              | 0           | 0            | 0           | 1,667,792        | (1,667,792)  |
| Debt Service Ratio     | -              | -           | -            | -           | 0.11             | 1.92         |

RESOLUTION

2022-04

DESIGN

STANDARDS &  
CONSTRUCTION  
SPECIFICATIONS

This Page is Blank Intentionally

**RESOLUTION NO: 2022-04**

**RESOLUTION ADOPTING THE  
CHOWCHILLA WATER DISTRICT STANDARD SPECIFICATIONS AND  
DRAWINGS FOR NEW DISTRICT FACILITIES AND/OR IMPROVEMENTS,  
REPAIRS AND MODIFICATION TO EXISTING DISTRICT FACILITIES**

WHEREAS, it is recommended by the General Manager of the Chowchilla Water District (“District”) and the District’s Engineering Firm that the District adopt the Standard Specifications and Drawings attached hereto as Exhibit A (“Standard Specifications”), and;

WHEREAS, from time to time the District will develop supplemental specifications to modify the Design Standards, and;

WHEREAS, the Design Standards, along with any supplemental specifications, will be used to design and construct public improvements within the District, and;

WHEREAS, it is the determination of the District’s Board of Directors that it would be in the best interest of the District to adopt the Design Standards.

NOW, THEREFORE, BE IT RESOLVED that the attached Design Standards are hereby adopted by the Board of Directors of the Chowchilla Water District.

AYES:

NOES:

ABSTAINING:

ABSENT:

ADOPTED AND APPROVED:                     May 11, 2022                    

\_\_\_\_\_  
*Kole Upton, President*

ATTEST: \_\_\_\_\_  
*Brandon Tomlinson, Secretary*

This Page is Blank Intentionally



# Standard Specifications and Drawings

**May 11, 2022**

**Chowchilla Water District  
327 Chowchilla Blvd.  
Chowchilla, CA 93610  
(559) 665-3747**

# Table of Contents

|     |                                                                  |      |
|-----|------------------------------------------------------------------|------|
| 1   | Compaction                                                       | 1-1  |
| 1.1 | Situations Requiring Mechanical Compaction during Backfill ..... | 1-1  |
| 1.2 | Methods of Compaction during Backfilling .....                   | 1-1  |
| 1.3 | Optimum Moisture for Backfilling .....                           | 1-2  |
| 1.4 | Optimum Compaction for Backfilling .....                         | 1-2  |
| 1.5 | Backfilling in Areas with Poor Soil.....                         | 1-2  |
| 2   | Gunite Lining/Shotcrete .....                                    | 2-3  |
| 2.1 | Definition.....                                                  | 2-3  |
| 2.2 | Reinforcement .....                                              | 2-3  |
| 2.3 | Gunite Thicknesses, Footings, Cutoff Walls .....                 | 2-3  |
| 2.4 | Ladders Installed in Lining .....                                | 2-4  |
| 2.5 | Material Specifications and Application .....                    | 2-4  |
| 2.6 | Gunite Lining Repair .....                                       | 2-4  |
| 3   | Slip Form Structures .....                                       | 3-5  |
| 3.1 | Definition and Use .....                                         | 3-5  |
| 3.2 | Material Specifications .....                                    | 3-5  |
| 3.3 | Form Preparation.....                                            | 3-5  |
| 3.4 | Slip Form Construction .....                                     | 3-5  |
| 3.5 | Baffle Wall Installation .....                                   | 3-6  |
| 3.6 | Precast Manhole Pipe Installation.....                           | 3-7  |
| 4   | Concrete Reinforced Structures.....                              | 4-7  |
| 4.1 | Excavation for Structure .....                                   | 4-7  |
| 4.2 | Formwork.....                                                    | 4-7  |
| 4.3 | Reinforcement .....                                              | 4-8  |
| 4.4 | Concrete Properties.....                                         | 4-8  |
| 4.5 | Concrete Placement .....                                         | 4-9  |
| 4.6 | Form Removal & Backfill .....                                    | 4-9  |
| 5   | Rubber Gasket Reinforced Concrete Pipe (RGRCP).....              | 5-10 |
| 5.1 | Manufacturer Specifications .....                                | 5-10 |
| 5.2 | Ordering, Receiving, Handling, and Distributing .....            | 5-10 |



|      |                                                                                     |              |
|------|-------------------------------------------------------------------------------------|--------------|
| 5.3  | Excavation .....                                                                    | 5-11         |
| 5.4  | Gaskets and Sealants at Connections .....                                           | 5-14         |
| 5.5  | RGRCP Pipe Installation .....                                                       | 5-15         |
| 5.6  | Backfilling .....                                                                   | 5-16         |
| 5.7  | Curved Alignment .....                                                              | 5-17         |
| 5.8  | Construction Testing .....                                                          | 5-17         |
| 5.9  | RGRCP Pipeline Repair .....                                                         | 5-17         |
| 6    | <b>Polyvinyl (PVC) Pipe .....</b>                                                   | <b>6-18</b>  |
| 6.1  | Manufacturer Specifications .....                                                   | 6-18         |
| 6.2  | Receiving, Unloading, & Storage .....                                               | 6-19         |
| 6.3  | Trench Preparation .....                                                            | 6-20         |
| 6.4  | Gasket Pipe Installation .....                                                      | 6-20         |
| 6.5  | Solvent/Glue Pipe Installation .....                                                | 6-21         |
| 6.6  | Pipe Filling & Testing .....                                                        | 6-24         |
| 6.7  | Pipe Backfill & Compaction .....                                                    | 6-25         |
| 6.8  | PVC Pipeline Repair .....                                                           | 6-25         |
| 7    | <b>Gate Installation 7-27</b>                                                       |              |
| 7.1  | CWD Required Gates .....                                                            | 7-27         |
| 7.2  | CWD Gate Specifications .....                                                       | 7-27         |
| 7.3  | FV&C Series 6600 Model 101C Gate Installation .....                                 | 7-27         |
| 7.4  | FV&C Type YW & PW Line Gate Installation .....                                      | 7-28         |
| 7.5  | Maintenance and Replacement .....                                                   | 7-30         |
| 8    | <b>OSHA Requirements .....</b>                                                      | <b>8-30</b>  |
| 9    | <b>Develop Procedures &amp; Requirements .....</b>                                  | <b>9-31</b>  |
| 9.1  | Development Procedure Involving Urban, Commercial, and Industrial Development ..... | 9-31         |
| 10   | <b>General Engineering &amp; Maintenance Concepts &amp; Procedures .....</b>        | <b>10-34</b> |
| 10.1 | Engineering Concepts .....                                                          | 10-34        |
| 10.2 | Standard Easement Width for Open Canals and Pipelines .....                         | 10-37        |
| 10.3 | Automation and Supervisory Control and Data Acquisition (SCADA) Notes .....         | 10-40        |

# List of Attachments

Attachment A – Standard Drawings

# 1 Compaction

## 1.1 Situations Requiring Mechanical Compaction during Backfill

Mechanical compaction may be required where loose backfill and subsequent settling will not be acceptable. The following situations will require mechanical compaction as described within this section and the appropriate section pursuant to each topic listed below:

- A) Trench Backfill
  - 1) Rubber Gasket Reinforced Concrete Pipe (RGRCP)
  - 2) Polyvinyl Chloride (PVC) Pipe
- B) Structure Backfill
  - 1) Formed Structures
  - 2) Precast & Slipform Stands
  - 3) Inlet/Outlet Structures
  - 4) Check Structures

Mechanical compaction may also be required in the following situations including but not limited to: Backfilling road crossings within public street rights-of-way, backfilling where vehicle traffic may cross pipelines or tailpipe, and compacting banks to be lined. Any situations where compaction will lessen the maintenance requirement of a Chowchilla Water District (CWD or District) facility, every effort should be made to compact all material as specified within this section. Each workman shall be responsible to make those situations known to his supervisor.

## 1.2 Methods of Compaction during Backfilling

The following pieces of equipment to be used for compaction:

- A) Hand Tampers  
Tampers shall be used to compact all soil types adjacent to structures or in confined spaces which larger equipment cannot access.
- B) Sheepsfoot  
Sheepsfoot roller shall be used to compact all soil types. Roller shall be used to compact lift thicknesses so that the foot will penetrate through the non-compacted material to the compacted material on the initial pass.
- C) Gradall/Backhoe/Excavator  
Each may be used for compaction on inaccessible slopes or in situations where compaction could put a worker at risk. Use should only be used in these situations since this equipment is not designed for compacting.
- D) Front end loaders and dozers should not be used for compaction.
- E) Vibratory Plate Attachments  
Vibratory plate attachments may be used in granular soil types.

### 1.3 Optimum Moisture for Backfilling

The following steps shall be used to obtain the optimum moisture based on the soil type. For silty clays, water shall be applied during backfilling so that a handful of soil which is squeezed makes a loose ball. If the soil material does not stick together, the soil is too dry and water should be added; and if the material leaves a soft mud on the skin or can be rolled into a “worm” similar to pottery clay, the soil is too wet, and dry material should be imported or the soil should be allowed to dry. For sandy soil, water shall be applied so that all material loses its light color, and in most situations, it will be nearly impossible to add too much water to sandy soils when backfilling. A general rule is that heavier soils will require little added water or often no water for compaction where lighter soils such as sand will require water to be added for compaction.

During any backfilling operation, water should be continuously applied to the backfilled material as described above to ensure that the soil through the entire backfilled profile is at the proper moisture. If the trench or excavation is not compacted and moistened when backfilled, the backfilled material should be “jetted” by applying water into the backfilled material through the entire profile. Jetting can be accomplished by inserting steel or plastic pipe from a water truck into the backfilled material and applying water at several depths which will fill voids and provide additional compacting of the backfilled material. However, caution should be used when jetting PVC pipe which could cause the pipe to float if empty, see Section 6 for more details.

If compaction is critical, a compaction test should be which will test the moisture of compacted material by using a Field Density Test.

### 1.4 Optimum Compaction for Backfilling

During any backfilling operation, adequate compaction can be field tested by the following: Remove some of the loose newly backfilled material and step onto existing backfilled material. If more than a 1/2 inch of the material compacts, the material is not compacted enough and will require mechanical compaction as discussed in Section 1.2, and/or water will be required as discussed in Section 1.3. The next test which may be used is ramming the handle end of a shovel into the backfilled material, and if the handle sinks more than 1 inch, the material is not compacted enough, and mechanical compaction should be used.

CWD does not own any compaction testing equipment or the properly licensed personnel to use such equipment. Where compaction is necessary, it is the responsibility of the workman’s supervisor to request compaction tests in any situation where he deems compaction is critical either to safe operation and maintenance of a CWD facility, or in situations where surface use will be negatively impacted by poor compaction.

### 1.5 Backfilling in Areas with Poor Soil

The majority of the District has fairly sandy soil which has good characteristics for backfilling and compacting. However, soils in the northeast area of the District tend to have a high clay content and lands planted with fig trees typically have soils with hard pan layers

which in both of these cases makes backfilling and compacting difficult. In these areas having poor native soils, it may be necessary to import sand material to obtain optimum compaction around the pipe and then backfill the remaining open trench with the native soil. Often, the native soil may be either too wet or dry during compaction so caution and good judgment should be used to prevent backfilling with material, which is too wet, or trying to add water to native material which is too dry.

## 2 Gunite Lining/Shotcrete

### 2.1 Definition

For the purposes of this section, the terms gunite and shotcrete will be used interchangeably with the understanding that gunite refers to the dry-mix shotcrete process as specified in the American Concrete Institute (ACI) codes 506, 506R, and 506.2. CWD will also allow the wet-mix shotcrete process pursuant to the same codes above. Any other processes or mix specifications not specified in the above codes shall be permissible only with prior CWD approval.

### 2.2 Reinforcement

Gunite lining reinforcement used on open canals and other lined tub structures is usually 6-6 x 10-10 welded wire fabric mesh which shall conform to ASTM A185 or ASTM A497 and may be uncoated or galvanized. Mesh shall be installed to lay flat and should have no wrinkles. CWD will allow the use of steel fibrous reinforcement which shall be 1.5-inch long in amounts of 2 percent by metered volume or 60 pounds per cubic yard of the gunite being used as determined by CWD'S Engineer. CWD will allow the use of 2-inch long Fibermesh reinforcement in amounts of 2 pounds per cubic yard. CWD will also allow the use of reinforcing bars (rebar) providing the use of bars shall not exceed #5 bar which shall be laid on 1-foot square spacing grid and tied together at each intersection. The use of adobe or brick chairs will be required at spacings to keep the reinforcement elevated off the ground surface so when the lining is applied the reinforcement is in the lower 30%-50% of the lining thickness. Anchors shall also be required at spacings to hold the reinforcement in place during lining application. Typical anchors are constructed of six 18-inch long, depending on the soil type, #3 or #4 rebar with a hook at one end to grab the reinforcement. The anchors are driven into the ground to a depth to provide rigid holding and so the hook doesn't extend through the finished lining surface.

Regardless of the reinforcement used, all material shall be free from oil, loose rust, mill scale, or other surface deposits which may affect the bond to the gunite. During gunite application, mesh and rebar reinforcement shall be pulled away from the soil surface so that the reinforcement is fixed at the center thickness of the lining.

### 2.3 Gunite Thicknesses, Footings, Cutoff Walls

All gunite applied to CWD facilities shall comply with the CWD Standard Specifications and Drawings. The lining requirements are as follows: the lining thickness shall be 6 inches thick

minimum on all canal bottoms including inlet/outlet bathtubs and stands, and all other slope protection uses, and shall remain 6 inches thick at the bottoms of all side slopes tapering to 4 inches thick at the top of the lined slope. In cases where a gunite-lined structure will require dredging as directed by CWD Maintenance Department or will be exposed to severe elements, the lining shall be 6 inches thick. Where required by CWD's Engineer, footings shall be constructed on all lining which shall be 6 inches thick and extend a minimum of 24 inches below the canal bottom where a floor is not poured. CWD will also require cutoff walls at the edge of any lining with cutoff walls in the canal being a minimum of 8 inches thick and 24 inches deep, and cutoff walls around the edge of lining atop the bank which is 4 inches thick and 8 inches deep. The use of cutoff walls and footings will prevent water from undermining the lining.

## 2.4 Ladders Installed in Lining

Ladders shall be installed on any lined section and shall comply with the CWD Standard Specifications and Drawings. In particular, ladders shall be installed on both sides of the canal at regular spacing as specified by CWD and at all structures which include check structures, road culverts, entrances to pipelines, and any other facility which will allow easy access to the canal. Ladders shall be tied to the lining reinforcement prior to gunite application. During the gunite application, all ladders shall be protected to avoid excess gunite build-up on the ladder and shall be cleaned after the gunite application.

## 2.5 Material Specifications and Application

CWD will require that all mix specifications and materials used in the mix conform to ACI specifications 506, 506R, and 506.2. CWD will also require that at least four 6-inch concrete cubes be sprayed by the Contractor into CWD's form for each job or for each 200 yards of gunite applied. CWD will maintain the cubes in the same environment as the applied gunite and will remove the cubes and test at 7 and 28 days. The minimum 28-day concrete strength shall be 4,000 psi. CWD will require that any contractor applying gunite on CWD's facilities have the appropriate registration for the nozzleman applying the gunite as specified in ACI code 506.3R.

## 2.6 Gunite Lining Repair

In situations where lining will be patched only, all cracks shall be washed and wire brushed clean to ensure all material and debris is removed from the concrete/gunite. In small cracks less than a 1/2 inch, a silicon based product, i.e. Sikaflex-IA, should be used by extruding enough material to fill the crack and then by applying enough pressure to the material to insure that it bonds to both sides of the crack. After the material has set, a mortar band mixed with an additive, i.e. white glue, can be placed over the repair.

In situations where a section of lining will be relined, all cracks shall be washed and wire brushed clean to ensure all material and debris is removed from the concrete/gunite. If the cracks need to be repaired prior to relining, mortar band repair as discussed in the above paragraph is adequate.

## 3 Slip Form Structures

### 3.1 Definition and Use

For the purposes of this section, slip form structures shall apply to all structures which have a reinforced poured-in-place concrete base, a below ground non-reinforced poured-in-place riser section using a prefabricated steel form for the interior of the structure, and an above ground precast pipe section. Slip form structures shall use concrete as specified in ACI Code 318-Structural Concrete, as specified in Section 3.2. Structures which may be slip formed are the following: back-up stands, inlet/outlet stands, and surge chambers as specified CWD Standard Specifications and Drawings.

### 3.2 Material Specifications

Concrete for non-reinforced, slip-form structures shall conform to ACI Code 318 and ASTM C150 and be 5.5 or 6 sack mix with a minimum compressive strength at 28 days of 3,000 psi. The concrete shall also have the following properties:

- 1) Cement shall be Type II and shall meet the requirements for low alkali.
- 2) Coarse Aggregate shall be no more than 1/5 the minimum wall thickness and shall be no larger than inches and shall conform to the latest revision of ASTM Specification C-33.
- 3) Water shall be clean and free substances which may be deleterious to the reinforcement or concrete.
- 4) Maximum Water-Cement ratio shall not exceed 46%.

Slump shall be approximately three inches at the job site as determined by a Slump Test. The slump batched at the concrete plant will vary depending on the travel time to the job site which should be determined prior to ordering any concrete.

Concrete shall not be placed when the air temperature in the shade, in the vicinity of the work exceeds 95°F, or when the temperature of the concrete exceeds 85°F.

### 3.3 Form Preparation

All forms used for slip-form stands shall be prefabricated steel forms and shall have a maximum of 2% deflection during construction. All dirt, chips, sawdust, nails, and other foreign matter shall be completely removed from forms before any concrete is deposited, and forms shall be thoroughly coated with form oil.

### 3.4 Slip Form Construction

- A) The trench shall be excavated to twelve inches below the specified stand invert elevation. The bottom and sides of the trench shall be prepared to provide full, firm, and uniform support by undisturbed earth or compacted fill. Where excavation

- occurs in rock or other hard material, sand shall be imported, moistened, and compacted as discussed in Section 1.
- B) All entering and leaving pipe shall be placed so that the top and bottom of pipe are flush with the interior of the stand. The sides of the pipe and inside of stand shall be troweled after the stand has been poured to form a smooth transition.
  - C) The base shall contain reinforcement consisting of #4 rebar on twelve-inch centers in perpendicular directions. The reinforcement shall be placed and tied on mortar blocks so that the reinforcement is elevated above the bottom of trench a minimum of three inches.
  - D) All surfaces against which concrete is to be placed shall be free from standing water, mud, and debris and shall be firm enough to prevent contamination of the concrete by earth or other foreign material.
  - E) At the time of concrete placement, all soil adjacent to the pipe shall be sufficiently wet so that it does not absorb water from the concrete or expand upon additional wetting.
  - F) The base shall be constructed in one placement. The concrete shall be rammed and tamped until it has been consolidated to the maximum practicable density and properly conforms against the reinforcement. The concrete shall be troweled to provide a smooth and level surface.
  - G) The walls of the slip form stand shall be constructed in one placement and shall immediately follow the construction of the base. Walls should be poured to an elevation that is a minimum of twelve inches below the surrounding grade, or to an elevation which allows installation of jointed precast pipe to the correct top of structure elevation. The concrete shall be vibrated, rammed, and tamped until the concrete has been consolidated to the maximum practicable density, free of rock pockets, and properly conforms against the form surface. Wall thickness should average approximately 12 inches at the base and approximately 8-10 inches at the top of the slip form pour.
  - H) Concrete shall not be placed when the air temperature in the shade, in the vicinity of the work exceeds 95°F, or when the temperature of the concrete exceeds 85°F.
  - I) The top of the slip-form stand shall be keyed to receive the tongue end of the precast riser section. The key shall be formed in the freshly poured concrete by using a template manufactured to the dimensions of the riser section.
  - J) After the concrete has adequately set but not hardened, approximately thirty minutes, the form shall be removed by “jerking” loose and removing vertically.
  - K) The interior of the stand shall be troweled smooth with a wooden trowel and all excess concrete shall be removed from the base and any incoming or outgoing pipe.

### 3.5 Baffle Wall Installation

After the slip form has been removed from the structure and interior finishing has occurred, #4 or #6 rebar shall be driven into the stand wall to a minimum of half the wall thickness. The rebar length shall be long enough so that a minimum of 6 inches protrudes from the stand wall to allow future installation of baffle wall reinforcement. Construction of the baffle wall shall be according to formed reinforced structure construction as discussed in Section 9.



## 3.6 Precast Manhole Pipe Installation

The slip form base and wall concrete shall cure a minimum of four hours before installation of any precast pipe riser section. After curing, precast pipe shall be placed and fitted into the keyway on the top of the slip-form wall. All joints shall be filled with a soft butyl formable rubber gasket prior to placement and banded with cement mortar after placement of precast sections. The interior and exposed exterior of the stand shall be troweled smooth with a wooden trowel, removing excess mortar extruded out of joints for the entire height of the stand.

Precast riser sections shall be reinforced concrete pipe and shall conform to ASTM Standard C478. Manhole material comes in 2-, 3-, and 4-foot sections. The job supervisor shall be responsible for slip form stand construction as described in Section 3.4 so that the top of the slip form stand is at an elevation to provide installation of intervals of 2-, 3-, or 4-foot sections to match the ultimate finish grade top of stand elevation.

## 4 Concrete Reinforced Structures

### 4.1 Excavation for Structure

#### A) Clay, Rock, Hardpan Soils

Where clay, rock subgrade, stones, or hardpan material larger than 1.5 inches are encountered, the excavation for structures shall be approximately four inches below the specified bottom pad elevation of the structure. A minimum of 4 inches of sand bedding should be placed, wetted, and compacted according to Section 1 above the surface. The sides of the trench shall be prepared to provide full, firm and uniform support by undisturbed earth or compacted fill.

#### B) Sandy Loam Soils

Where structures will be constructed in lighter soils such as sandy or loam soils, the excavation should provide a uniform stable support for the structure and should be free of any irregularities that could cause point loads on the structure. Regardless of the soil type, it is recommended but not required except for soils in 4.1 A, that a minimum of a two-inch sand bedding be used which is compacted and wetted as specified in Section 1.

#### C) OSHA Requirements

Excavations for structures shall be performed according to Section 8, OSHA Excavation Requirements.

### 4.2 Formwork

- A) All forms shall conform to the shape, line, grade, and dimensions of the structure or structures as shown on the plans and drawings.
- B) All forms shall have sufficient strength and be tied together and braced in such a manner to withstand the internal pressure resulting from the placement and vibrating of the concrete.

- C) Forms shall be constructed in such a manner as to remain in the correct position.
- D) All forms that are exposed to the surface of the concrete to be placed shall be smooth and sufficiently tight to prevent loss of concrete or its components through the form joint.
- E) Snap ties shall be used at spacings to hold the forms in place and shall remain embedded in the concrete until the concrete has sufficiently set. The ties shall be removed when the forms are removed with no metal remaining within one inch (1") of any surface. Any holes left by the snap ties shall be patched.
- F) Prior to concrete placement, all forms shall be lubricated to prevent concrete from sticking to the forms.

### 4.3 Reinforcement

Reinforcement used for formed structures shall conform to ACI 318 and be of the size, type, and spacings as specified on the plans and drawings for the structure. The use of adobe or brick spacers may be required at spacings to keep the reinforcement centered in the wall thickness so when the concrete is poured into the form the reinforcement is not pushed against the form. For all structures having a pad, the reinforcement in the pad shall be bent so that a minimum of 12 inches of reinforcement extends above the finished pad elevation. During wall construction, wall reinforcement shall be tied to the floor reinforcement. All reinforcement intersections shall be tied together so as to prevent movement of the reinforcement during the forming or pouring of the structure. Regardless of the reinforcement used, all material shall be free from oil, loose rust, mill scale, or other surface deposits which may affect the bond to the concrete.

### 4.4 Concrete Properties

- A) Cement shall be Type II, low alkali, and shall conform to the requirement of ASTM C150, and shall be the same type for the same element or portion of the work.
- B) Unless otherwise specified, the strength of concrete shall be at least 3,000 psi as determined on the basis of 28-day compressive strength tests when the concrete is not exposed to severe and frequent freezing and thawing.
- C) All concrete shall have a water-cement ratio not exceeding 0.53 by weight, including free moisture on aggregate.
- D) Slump shall be determined in accordance with ASTM C143. Slump shall be the minimum required for satisfactory placement of the concrete by the equipment and crew. Structure wall thickness which is 6 inches or less will require slump of approximately 4-5 inches at the job site to ensure that concrete will form a solid and consistent wall throughout the structure. Concrete which has a dryer slump will tend to have rock pockets and voids which will require patching after the forms have been removed and will require increased maintenance. Thicker structure walls will require a dryer slump of approximately 3-4 inches at the job site. Slump shall be checked using the rod and cone method.
- E) Concrete shall be ready mixed meeting the requirements of ASTM C94. All concrete shall be mixed until there is a uniform distribution of materials which for most concrete trucks

is 90 revolutions per minute (RPM) for two minutes. Failure to mix concrete prior to pouring will cause separation of concrete materials.

## 4.5 Concrete Placement

### A) Method of Placement

The structure shall be constructed in placements as required to construct the structure pad, walls, and other appurtenances. The concrete shall be vibrated, rammed, tamped, or worked with suitable compacting equipment until thoroughly consolidated. Concrete shall be deposited as nearly as possible in its final position and shall not be caused to flow in a manner to permit or cause separation. Excessive separation of coarse aggregate from the concrete caused by allowing the concrete to fall freely from too great of height will not be allowed.

### B) Construction Joints

When work is stopped at the end of placement or for any period of time that would permit initial set to take place, a construction joint shall be formed. Immediately before resuming concrete placement, the surfaces to be bonded shall be cleaned of all coatings, foreign material, and loose or defective concrete, thoroughly wetted, and coated with a waterstop compound.

### C) Forms

The surface of the forms shall be free from mortar, grout, concrete, or other foreign material that would contaminate the new concrete or interfere with the attainment of the desired finish on the formed surfaces. Before the concrete is placed, the form surface shall be oiled to prevent the concrete from sticking to the form surface.

### D) Temperature

The temperature of concrete when it is being discharged from the mixer shall be no more than 90°F and not less than 40°F in moderate weather, or 50°F in weather during which the mean daily temperature drops below 40°F. Whenever the mean daily temperature in the vicinity of the work site falls below 40°F for more than 1 day, the concrete shall be maintained at a temperature not lower than 50°F for at 48 hours after it is placed.

### E) Addition of Water to Mixture

In most instances, water will be added to the concrete mixture at the job site to obtain the correct slump. However, caution should be used since the addition of excess water can decrease the concrete strength and increase the slump. Also, if enough time elapses between batching and delivery of the concrete, the mixture may begin setting which will be evidenced by high concrete temperatures compared to the batch temperature, and the tendency of the concrete not to mix well in the truck. If it is believed that the concrete has begun its initial setting due to temperature, delivery time or other factors, serious consideration should be given to rejecting the concrete and simultaneously contacting the appropriate supervisor.

## 4.6 Form Removal & Backfill

### A) Form Removal

All forms shall be normally removed as soon as practical in order to delay curing of the concrete by application of a curing compound or by periodic moistening of the concrete with water. However, the forms shall not be removed until the strength of the concrete is such that no damage will be done to the concrete by removal of the forms.

B) Defects in Concrete

After the forms have been removed from the structure, the concrete shall be immediately inspected for surface irregularities caused by misplaced forms, poor consolidation, or any other defects. Excessive bulges or projections shall be removed, and the surface finished with grout or cement mortar. All rock pockets or voids shall be entirely removed until solid concrete is reached, the edges cut square, the old concrete saturated with water, and the space filled with concrete or mortar held in place with forms if necessary.

C) Curing and Protection

All reinforced concrete structures shall be cured by using a curing membrane which will form a water retaining membrane on the surface of the concrete. As an alternative, water may be used to keep the concrete moistened such that the concrete retains a dark gray color until the structure is backfilled.

D) Backfill

The structure shall be backfilled with clean material which shall be free from hardpan, rocks, or other debris which will prevent compaction as specified in Section 1.

## 5 Rubber Gasket Reinforced Concrete Pipe (RGRCP)

### 5.1 Manufacturer Specifications

1. Rubber Gasket Reinforced Concrete Pipe Reinforced Concrete Pipe per ANSI/ASTM C76 (Class 3, unless otherwise indicated on the construction drawings), with rubber gasket joints per ANSI/ASTM C443.

### 5.2 Ordering, Receiving, Handling, and Distributing

A) Ordering

When ordering RGRCP pipe, the following must be included to ensure the correct type and class of pipe is delivered:

- 1) Pipe Diameter
- 2) Pipe Class, ASTM C-76 or C-361
- 3) Laying Length, normally in either 8- or 12-foot lengths
- 4) Total footage
- 5) Type of joint, CWD will use Bell and Spigot Joints
- 6) Delivery Location and Schedule

B) Receiving

Pipe delivered to the construction site has been plant inspected, but a field check should be made to ensure that the pipe is clearly marked with the following information:

- 1) Specification designation

- 2) Pipe class or strength designation
  - 3) Date of manufacture
  - 4) Name or trademark of the manufacturer
  - 5) Plant identification
- C) Handling and Unloading
- It is the responsibility of the receiver to determine that damage has not occurred during delivery. An overall inspection of each pipe shipment should be made before unloading and total quantities of each item checked against the delivery slip and damaged or missing items recorded. The pipe should be unloaded by lowering the pipe in controlled manner to prevent collision with other pipe sections or fittings and care should be taken to avoid chipping or spalling, especially to joint surfaces. Caution is necessary to ensure workers are out of the path of the pipe as it is lowered down the skid. If the pipe is moved after unloading, the sections should be rolled or lifted and never dragged or rolled over rough or rocky terrain. Mechanical equipment is necessary for unloading the larger sizes of pipe and usually simplifies and speeds up the unloading of smaller pipe. When mechanical equipment is used, the lifting device which supports the pipe must provide safe handling without damaging the pipe. Many carriers are equipped with automatic unloaders. These unloaders consist of a forklift type apparatus mounted at the rear of a flatbed truck. The forks rotate vertically rather than moving up and down, so that when the forks are in a vertical position, they extend above the truck bed. This provides a backstop and cushion for the pipe sections as they are rolled to the rear of the truck for unloading. A cradle formed by the forks and unloader frame securely retains the pipe section being unloaded as the forks are rotated downward and lowered to the ground.
- D) Distributing
- Coordination of pipe delivery with installation will avoid unnecessary handling and equipment movement. For trench installations, the pipe should be placed on the trench side away from the excavated material. If the pipeline is to be installed adjacent to a road right-of-way, the pipe should be strung out between the trench and road to prevent vehicles from driving into the trench. For embankment installations, with pipe to be installed on a shallow bedding at approximately the same elevation as original ground, the pipe can be strung out immediately after clearing and rough grading.

### 5.3 Excavation

- A) Excavation, pipe installation and backfill operations should succeed each other as rapidly as possible. Avoiding long stretches of open trench will:
- 1) Reduce equipment requirements
  - 2) Reduce sheathing and shoring required at any one time
  - 3) Prevent trench flooding
  - 4) Reduce the need to control groundwater
  - 5) Minimize disruption to existing utilities
  - 6) Simplify traffic maintenance
  - 7) Reduce safety hazards
  - 8) Permit closer supervision and inspection of the work
  - 9) Permit better quality control

- 10) Reduce adverse environmental impacts
- 11) Assist in maintaining better public relations
- B) For irrigation pipeline construction, the most important excavation limitations are trench width and depth. As excavation progresses, trench grades are continuously checked to obtain the elevations established on the pipeline profile. Incorrect trench depths may adversely affect the flow capacity of the pipeline, require more vents to relieve trapped air, and may require additional maintenance after the line is completed.
- C) The backfill load ultimately transmitted to the pipe is a function of trench width so trench widths should be as narrow as established in the plans or standard drawings. Side clearance must be adequate to permit proper compaction of backfill material at the sides of the pipe, and trenches are usually designed for a width of 1.25 times the outside diameter of the pipe plus one foot.
- D) The placement and storage of excavated material is an important consideration in pipeline construction and influences the selection of excavating equipment, the need for providing sheathing and shoring, and backfilling operations. For trench installations the excavated material is usually used for backfill, and the material stockpiled along the trench in such a manner as to reduce unnecessary handling during backfill operations. The distance excavated material is placed from the trench is controlled by site conditions, dumping radius, and casting capabilities of the equipment. A general rule for spoil placement along unsupported trenches is that the minimum distance from the trench sides to the toe of the spoil bank should not be less than one half the trench depth. If the trench walls are supported, a minimum distance of three feet from the edge of the trench to the toe of the spoil bank is usually sufficient. Stockpiling excavated material adjacent to the trench produces a surcharge load. The ability of the trench walls to stand under this additional load depends on the cohesive properties of the soil. Any surcharge load should be considered when evaluating the need to provide trench support. When deep or wide trenches are excavated, it may be necessary to haul away a portion of the excavated soil or spread the stockpile. If the excavated material is to be used as backfill, the stockpile should be visually inspected for rocks, frozen lumps, highly organic or plastic clays, and other objectionable material. If the excavated soil differs significantly from the type of backfill material specified, it may be necessary to remove the unsuitable soil and bring in a select backfill.
- E) Trench stabilization is usually accomplished through the use of sheathing and shoring. The Occupational Safety and Health Administration and many states, municipalities and other local agencies have established codes of safe practice regarding support requirements for trench excavation. The structural requirements of sheathing and shoring depend on:
  - 1) Depth and width of excavation
  - 2) Characteristics of the soil
  - 3) Water content of the soil
  - 4) Water table
  - 5) Weather conditions
  - 6) Proximity of other structures
  - 7) Vibration from construction equipment and traffic
  - 8) Spoil placement or other surcharge loads
  - 9) Code requirements



- If any of the above conditions are encountered, a trench shield can be used which is a heavily braced steel or wood box which is moved along the trench bottom as excavation and pipe laying progress. Trench boxes are used to protect workmen installing pipe in stable soil where the trenches are deep and unsheathed. Trench shields are also used in lieu of other methods of sheathing and shoring for shallow excavations where the sides of the shield can extend from the trench bottom to the ground surface. When trench shields are used, care must be taken to avoid pulling the pipe apart or disrupting the bedding as the shield is moved. Improper removal of sheathing can reduce soil friction along the trench wall and increase the backfill load on the pipe. Therefore, sheathing should be removed in increments as the backfill is placed. Additional compaction of the backfill material may be necessary to fill any voids left by the sheathing.
- F) A stable and uniform foundation is necessary for satisfactory performance of any pipe. The foundation must have sufficient load bearing capacity to maintain the pipe in proper alignment and sustain the loads imposed. The foundation should be checked for hard or soft spots. Where undesirable foundations exist, they should be stabilized by ballasting or soil modification. Ballasting requires removal of undesirable foundation material and replacement with select materials such as sand, gravel, crushed rock, slag, or suitable earth backfill. The depth, gradation and size of the ballast depends on the specific material used and the amount of stabilization required. The ballast is usually well graded from coarse to fine, having a size not more than one inch per foot of pipe diameter with three inches maximum and placed to a minimum depth of four inches. Soil modification involves the addition of select material to the native soil. Crushed rock, gravel, sand, slag, or other durable inert materials with a maximum size of three inches is worked into the subsoil to accomplish the required stabilization. Soil modification can also be accomplished by the addition of lime, cement, or chemicals to the soil. Adequate foundation stability is difficult to evaluate by visual observation. However, when concrete pipe is set on the foundation with little or no care exercised to provide a bearing surface, the weight of the pipe exerts a pressure of approximately 1,000 pounds per square foot. This pressure is about the same pressure a 200-pound man would exert when standing on one foot. If the foundation can support men working in the trench without sinking into the soil, the foundation should be stable enough to support the pipe and maintain it in proper alignment.
- G) Once a stable and uniform foundation is provided, it is necessary to prepare the bedding in accordance with the requirements of the plans, specifications, or standard drawings. An important function of the bedding is to assure uniform support along the barrel of each pipe section. The bedding distributes the load reaction around the lower periphery of the pipe. The required supporting strength of the pipe is directly related to this load distribution, and several types of bedding have been established to enable specification of pipe strengths during the design phase of the project. Pipe set on a flat foundation without bedding results in high load concentration at the bottom of the pipe. Bedding the pipe so that the bottom reaction is distributed over 50 percent of the outside horizontal span of the pipe results in a 36 percent increase in supporting strength; a 60 percent distribution results in a 73 percent increase for the same amount of settlement; and a 100 percent distribution results in as much as a 150 percent increase depending on backfill compaction. If the pipe strength specified for a particular project is

based on a design assumption that at least 60 percent of the outside horizontal span of the pipe is bedded, and the pipe is actually set on a flat foundation, a pipe strength significantly greater than specified would be required. The bedding being constructed needs to be continuously compared with the requirements in the plans or specifications.

## 5.4 Gaskets and Sealants at Connections

- A) Rubber gaskets are either flat gaskets which may be cemented to the pipe tongue or spigot during manufacture, O-ring gaskets which are recessed in a groove on the pipe tongue or spigot and then confined by the bell or groove after the joint is completed, or roll-on gaskets which are placed around the tongue or spigot and then rolled into position as the tongue or spigot is inserted into the bell or groove. When gaskets are used, dust, dirt and foreign matter must be removed from the joint surfaces. For flat and O-ring gaskets, the gasket and joint surfaces are lubricated with a lubricant recommended by the manufacturer. The lubricant can be applied with a brush, cloth pad, sponge, or glove. For all gaskets not cemented to the pipe, a smooth round object should be inserted under the gasket and run around the circumference two or three times to equalize stretch in the gasket.
- B) Mastic sealants consist of bitumen and inert mineral filler and are usually cold applied. The joint surfaces are thoroughly cleaned, dried, and prepared in accordance with the manufacturer's recommendations. A sufficient amount of sealant is used to fill the annular joint space with some squeezed out. Better workability of the mastic sealant can be obtained during cold weather if the mastic and joint surfaces are heated.
- C) Cement sealants consist of Portland cement paste or mortar made with a mixture of Portland cement, sand, and water. The joint surface is thoroughly cleaned and soaked with water immediately before the joint is made. A layer of paste or mortar is placed in the lower portion of the bell or groove end of the installed pipe and on the upper portion of the tongue or spigot end of the pipe section to be installed. The tongue or spigot is then inserted into the bell or groove of the installed pipe until the sealant material is squeezed out. Any annular joint space between the adjacent pipe ends is filled with mortar and the excess mortar on the inside of the pipes wiped and finished to a smooth surface.
- D) Portland cement mortar bands are sometimes specified around the interior of the pipe joint. A slight depression is excavated in the bedding material to enable mortar to be placed underneath the pipe. The entire external joint surface is then cleaned and soaked with water. Special canvas or cloth diapers can be used to hold the mortar as it is placed. Backfill material should be immediately placed around the pipe.
- E) Rubber-mastic bands also can be used around the exterior of the pipe joint. After application of the mastic, a concrete collar should be poured around the band.
- F) All pipe connections to structures and existing pipelines shall be reinforced concrete collar connections per the CWD Specifications and Drawings.



## 5.5 RGRCP Pipe Installation

- A) The pipe is elevated outside the trench where a gasket is placed on the spigot end. After the gasket is installed, lubricant is applied to the gasket to allow it to slide into the bell without slipping.
- B) The bottom of trench is prepared by levelling the trench to provide for a uniform surface under the pipe.
- C) The pipe length is measured from the bell end to determine the location of the next bell. At that point, a hole is dug in the trench bottom which allows the pipe to lay flat in the trench which prevents the bell from taking the loading from the pipe weight and loading from backfilling and compaction operations.
- D) Lubricant is applied to the bell end of the last pipe laid in the trench. Care should be taken that all dirt is removed prior and after the lubricant is applied to the bell end.
- E) The pipe section to be installed should be aligned as closely as possible to the axis of the last installed pipe section. The pipe should be lowered into the trench so that the top of the spigot pipe end should be inserted into top of the bell end. The pipe should then be lowered so that the bell makes contact with the trench bottom.
- F) The pipe should be joined to the existing pipe by the following:
  - 1) Breaker Bar  
Joints for pipe sizes up to 30 inches in diameter can usually be assembled by means of a bar. A bar is then driven into the bedding and wedged against the bottom bell or groove end of the pipe section being installed. A wood block is placed horizontally across the end of the pipe to act as a fulcrum point and to protect the joint end during assembly. By pushing the top of the vertical bar forward, lever action pushes the pipe into a home position.
  - 2) Come Along  
When jointing larger diameter pipe, and when granular bedding is used, mechanical pipe pullers are required. Several types of pipe pullers or come along devices have been developed but the basic force principles are the same. When jointing small diameter pipe, a chain or cable is wrapped around the barrel of the pipe a few feet behind the tongue or spigot and fastened with a grab hook or other suitable connecting device. A lever assembly is anchored to the installed pipe, several sections back from the last installed section, and connected by means of a chain or cable to the grab hook on the pipe to be installed. By pulling the lever back, the tongue or spigot of the pipe being jointed is pulled into the bell or groove of the last installed pipe section. To maintain close control over the alignment of the pipe, a laying sling can be used to lift the pipe section slightly off the bedding foundation.
  - 3) Dead man blocking  
Large diameter pipe can be joined by placing a dead man blocking inside the installed pipe, several sections back from the last installed section, which is connected by means of a chain or cable to a strong back placed across the end of the pipe section being installed. The pipe is pulled home by lever action similar to the external assembly. Mechanical details of the specific apparatus used for pipe pullers or come along devices may vary, but the basic lever action principle is used to develop the necessary controlled pulling force.

4) Heavy equipment

In some situations, the use of excavating equipment may be used to push pipe sections together, however, this should be avoided unless provisions are made to prevent localized overstressing of the pipe joints such as the use of wood blocking or using the flat side of the bucket which applies pressure evenly around the circumference of the pipe.

## 5.6 Backfilling

The backfill consists of two zones with separate material and compaction criteria. The first zone extends from the bedding to a plane approximately 12 inches above the top of the pipe. The second zone includes all of the remaining fill.

### A) Backfilling Around Pipe

The load carrying capacity of an installed pipe is largely dependent on the initial backfilling around the pipe. Because of the importance of obtaining proper compaction of backfill material immediately around the pipe, material and density criteria are often included as part of the bedding requirements. For trench installations, where space is limited, tamping by pneumatic or mechanical impact tampers is usually the most effective means of compaction. Impact tampers which compact by static weight and kneading action are primarily useful for clay soils, while granular soils are most effectively consolidated by vibration. Where impact type tampers are used, caution should be exercised to prevent direct blows on the pipe. Backfill material should be compacted and brought up in even layers on both sides of the pipe. The backfill material should not be bulldozed into the trench or dropped directly on the pipe. Heavy vibratory equipment should not be permitted to operate directly over the pipe until a minimum of three feet of backfill has been placed.

### B) Final Backfilling

Once the backfill material is placed around the pipe and properly compacted, the remainder of the fill is placed and compacted to prevent settlement at the surface. Several types of compaction equipment are available and certain types are best for particular soils. The steel wheeled roller is best suited for compacting coarse aggregate such as slag, coarse gravel, and graded rock. The sheepsfoot roller is best suited for cohesive clays or silts and is not suitable for use on granular soils. Rubber tired rollers, which provide static weight and kneading action, are effective for many soils. Vibratory rollers are effective for granular materials. If the pipe is not under a roadway, sidewalk or other proposed structure, and possible settlement at the surface is not critical, flooding or jetting can be used to compact the backfill material. Water flooding and jetting are limited to compacting soils which are sufficiently permeable to dispose of the excess water and should not be used with cohesive soils. The trench is usually flooded until the backfill material is thoroughly saturated and has subsided from six to 18 inches. After initial saturation and subsidence, water is jetted into the backfill to the pipe depth at intervals varying from three to six feet. This process is repeated until the full depth of backfill material is placed.

## 5.7 Curved Alignment

Changes in direction and grades of pipelines are usually accomplished at manhole structures or prefabricated bends. Alignment changes in concrete pipelines, however, can be accomplished with deflected straight pipe or radius pipe. Since manufacturing and installation feasibility will determine the particular method used to negotiate a curve, the method must be established prior to trench excavation. For deflected straight pipe, the joint of each section is opened on one side while the other side remains in the home position. The difference between the home and opened joint space is generally designated as the pull. The maximum permissible pull is limited to an opening which will provide satisfactory joint performance. Based on manufacturer's specifications, pulling of joints up to three degrees (about 2 inches from pipe centerline) is permissible on spun pipe (ASTM C-361), however, no pull is allowed on pipe (ASTM C-76).

Radius pipe, also referred to as beveled or mitered pipe, incorporates the deflection angle in the pipe joint. The pipe is manufactured by shortening one side, and the amount of shortening, drop, for any given pipe is dependent on manufacturing feasibility. Because of the possibility of greater deflection angles per joint, sharper curvature with a correspondingly shorter radius can be obtained with radius pipe than with deflected straight pipe. When establishing alignment for radius pipe, the first section of radius pipe begins one-half of a pipe length beyond the point of curvature and the last section of radius pipe extends one-half of a pipe length beyond the point of tangent.

One or more of these methods may be employed to meet the most extreme alignment requirements. Since manufacturing processes and standards vary, local concrete pipe manufacturers should be consulted to determine the geometric configuration of pipe sections available. Many manufacturers have standardized joint configurations and deflections for specific radii and economies may be realized by using standard pipe.

## 5.8 Construction Testing

Tests included in the standards under which the pipe is purchased assure that pipe delivered to the job site meets or exceeds the requirements established for a particular project. The project specifications usually include acceptance test criteria to assure that reasonable quality of workmanship and materials has been realized during the construction phase of the project. Tests applicable to all storm sewer, sanitary sewer and culvert projects are soil density, line and grade and visual inspection.

## 5.9 RGRCP Pipeline Repair

### A) A Pipeline Shutdown and Access

- 1) If the pipeline is being used for deliveries, the system should be shutdown with an authorized shutdown from the water department. The headgate should be locked shut to prevent water from flowing into the system.
- 2) If the pipeline is not being used, a shutdown authorization is not required, however, the headgate should be locked shut to prevent water from flowing into the system.

- 3) The pipeline should be pumped dry from locations such as boxes, stands, vents. If plans show that the leak is at a low section of the pipeline or no structures exist close to the leak, it may be necessary to knock a hole in the pipeline to complete pumping and access the pipeline.
- 4) When the pipeline is accessed, ventilation blowers should be used to provide fresh air during operation.
- 5) Vehicles should be parked close to access point so the outside man can hear men inside pipeline in case of emergency.
- 6) Prior to access, the required confined space permit shall be obtained.
- 7) Prior to access, gas detectors should be used to check for harmful gases.
- 8) After the pipe has been accessed to determine why the pipe is leaking, one of the following repair methods should be used:
  - B) Bell/Spigot Joint Repair
    - 1) In most cases, RGRCP pipe will leak at the joint connection which may be caused from a poorly formed pipe joint, the gasket being rolled during installation, poor subgrade, or excess joint gap or deflection. If the joint is leaking, the following repair method should be used:
      - a) If the surface is not free of silt, debris, or trash, the void should be cleaned to insure bonding to the existing concrete.
      - b) Sikaflex 1-A or an approved equivalent should be used to fill the joint and should be pressed and set into the crack to insure the Sikaflex or the approved equivalent sticks to the concrete.
      - c) A liquid bonding agent such as “white glue” should be applied over the joint and on the pipe wall which will allow for new grout/concrete to be applied to the pipe wall. The bonding agent will ensure that the repair will adhere to the existing concrete. The bonding agent should be applied according to the manufacturer specifications.
      - d) The joint should be covered using a suitable grout mixed with a liquid bonding agent such as "white glue" according to manufacturer specifications. The bonding agent will increase the grout strength and make it less susceptible to drying out and cracking.
      - e) After the repair has been made on the inside, a supervisor should be consulted to determine whether or not a concrete collar should be used on the exterior of the pipe.
    - C) Pipe Section Failure Repair
      - 1) If the leak appears to be caused by pipe fatigue, failure, or decay, a supervisor should be consulted.
      - 2) If the supervisor determines that the pipe cannot be repaired, the section of pipe should be removed and replaced with RGRCP pipe according to this Section.

## 6 Polyvinyl (PVC) Pipe

### 6.1 Manufacturer Specifications

Pacific Western Extruded Plastics Company (PWPipe) produces PVC municipal water (Cast Iron Pipe Size) pipe in conformance with AWWA Standards C900 and C905, IPS (Iron Pipe

Size) pipe in conformance with ASTM D2214, and PIP (Plastic Irrigation Pipe) in conformance with ASAE and SCS specifications. PWPipe recommends that the pipe be installed according to this guide, AWWA Manual M23, and ASTM D2774. PWPipe or an approved equivalent shall be used depending on availability.

## 6.2 Receiving, Unloading, & Storage

### A) Receiving

When receiving the pipe shipment at the job site, exercise established precautions.

Each pipe shipment should be inventoried and inspected with care to ensure that there has been no loss or damage. The following procedures are recommended for acceptance of delivery:

- 1) Make overall examination of the load. If the load is intact, ordinary inspection while unloading should be sufficient to ensure that the pipe has arrived in good condition. If the load has shifted, has broken packaging, or shows rough treatment, carefully inspect each piece for damage.
- 2) Check total quantities of each item against shipping records.
- 3) Note any damaged or missing items on the delivery receipt. Notify the carrier immediately and make a claim according to his instructions. Do not dispose of any damaged material. The carrier will notify you of the procedure to follow.

### B) Unloading

The means by which the pipe is unloaded in the field is the decision and the responsibility of the receiver. These recommendations should be followed:

- 1) Remove restraints from the top unit loads. These may be either straps, ropes, or chains with padding.
- 2) Remove any boards on the top or sides of the load which are not part of the pipe packaging.
- 3) Using a forklift with thin chisel forks (or a front-end loader equipped with forks), remove the top units one at a time from the truck.
- 4) If a forklift is not available, use a spreader bar with fabric straps capable of carrying the load. Space straps approximately eight feet apart. Loop straps under the load. Cables may be used only if they are cushioned to prevent damage to the pipe.
- 5) During the removal and handling, ensure that the units do not impact anything especially in cold weather.
- 6) Place pipe package units on level ground.
- 7) Do not handle units with individual chains or single cables, even if padded.
- 8) Do not attach lifting cables to unit frames or bands.
- 9) Do not stack package units more than eight feet high.
- 10) Protect units with packing materials the same way they were protected while on the truck.
- 11) To unload lower units, repeat the unloading process described above.
- 12) Do not unload by hand.

### C) Storage

The following procedures are recommended to prevent damage to the pipe:

- 1) Store the pipe at the site in unit packages.

- 2) Avoid compression, deformation or damage to bell ends of the pipe.
- 3) When unit packages are stacked, ensure that the weight of upper units does not cause deformation to pipe in lower units.
- 4) Support pipe unit packages on wood blocking to prevent damage to the bottom surfaces during storage. Space supports to prevent pipe bending.
- 5) Store solvent cement in tightly sealed containers away from excessive heat.
- 6) Do not store pipe where gaskets may be exposed to ozone, grease, or oil.
- 7) Protect pipe interior and sealing surfaces from dirt and foreign matter.
- 8) When unit packages are stacked, ensure that the stack remains stable.

### 6.3 Trench Preparation

- A) The trench bottom should provide a uniform stable support for the pipe. The soil surface at the bottom of the trench should be free of any irregularities that could cause point loads on the pipe or bell.
- B) Where dewatering of the trench is necessary, water should be removed until the pipe has been installed and the backfill has been placed to a sufficient height to prevent flotation of the pipeline.
- C) Where live loads are expected on the pipe, the pipe should be installed a minimum of 3 feet below the finish grade surface.
- D) Where an unstable trench bottom condition occurs, special foundations may be required. A layer of sand bedding material should be placed between foundation and pipe.
- E) Where rock subgrade, stones, or hardpan material larger than 1.5 inches are encountered, a minimum of 4 inches of sand bedding should be placed under the pipe above the rock.

### 6.4 Gasket Pipe Installation

- A) When distributing pipe along a trench (stringing), place pipe on the opposite side of the trench from the spoil pile. Place pipe with bell ends in the direction of the work progress.
- B) Clean the gasket area. Remove sand, dirt, grease, and debris. Do not remove gaskets from bells, removal could cause improper reinstallation.
- C) Check the gasket. Make sure the gasket is seated uniformly in the groove by running a finger around the inner edge of the gasket.
- D) Clean the spigot. Use a rag to wipe the spigot clean.
- E) Excavate a hole for the pipe bell and lower the pipe into the trench. Lower carefully to avoid getting dirt into the bell or spigot.
- F) Apply lubricant to the bevel of the spigot end and approximately midway back to the stop line. A thin layer of lubricant may be applied to the face of the gasket but be careful not to get lubricant behind or under the gasket. Use only those lubricants supplied by PWPipe or an approved equivalent because use of other lubricants may cause deterioration of pipe or gasket.



- G) Keep lubricated areas clean. If dirt or sand adheres to lubricated areas, clean and re-lubricate.
- H) Insert the spigot end into the pipe until it contacts the gasket uniformly. Straight alignment is essential for ease of assembly. Apply steady pressure by hand or by mechanical means (bar and block, come-along, hydraulic jack) until the spigot slips through the gasket. Insert pipe until the stop line is flush with the bell end. Do not use a backhoe bucket for assembly, the action of the bucket can damage bells or dislodge gaskets from raceways.
- I) If undue resistance to pipe insertion is encountered or if the pipe cannot be inserted to the reference mark, disassemble the joint and check the position of the gasket.
  - 1) If the gasket has been dislodged from the race, inspect the pipe and gasket for damage, replace damaged items, clean the components, and repeat the assembly steps, assuring straight alignment.
  - 2) If the gasket is still properly positioned, verify proper positioning of the reference mark. Relocate the mark if it is not correctly positioned. In general, fittings allow less pipe insertion than do pipe bells. If the pipe still cannot be inserted properly, contact the supervisor, and if needed, call the supplier for assistance.
- J) If the pipe must be field-cut, mark the entire circumference of the pipe to insure a square cut. The pipe can be cut with a hacksaw, handsaw, or power handsaw with a steel blade or abrasive disc. Bevel the cut end using a pipe beveling tool or a portable sander or abrasive disc. Round off any sharp edges on the leading edge of the bevel with a pocket knife or a file. Mark cut end with an insertion line similar to uncut pipe.

## 6.5 Solvent/Glue Pipe Installation

- A) When distributing pipe along a trench (stringing), place pipe on the opposite side of the trench from the spoil pile. Place pipe with bell ends in the direction of the work progress. Pipe should be laid 1 day in advance.
- B) Basic principles of solvent-cemented joints:
  - 1) The joining surfaces must be clean and dry.
  - 2) The joining surfaces must be softened and made semi-fluid.
  - 3) Sufficient cement must be applied to fill the gap between male and female ends.
  - 4) The assembly must be made while the surfaces are still wet and fluid.
  - 5) Joint strength develops as the cement dries. In the tight part of the joint, the surfaces will fuse together. And in the loose part, the cement will bond with both surfaces.
  - 6) Completed joints should not be disturbed until they have cured sufficiently to withstand handling.
  - 7) For solvent weld pipe, the manufacturer states that no horizontal or vertical deflection is permitted.
- C) Selection of Solvent Cement
  - 1) PVC solvent cements are available in a variety of viscosities and wet film thicknesses to cover a wide range of pipe sizes, and for interference-fit joints as well as non-interference joints. The solvent cement manufacturer's recommendations should be followed for selection of proper cement.
  - 2) PVC solvent cements should be stored in a cool place except when actually in use at the job site. Cements have a limited shelf life when not stored in hermetically sealed

containers. (Screw-top containers are not considered to be hermetically sealed.) Consult the cement manufacturer for specific recommendations on storage conditions and shelf life. The cement is unsuitable for use if it exhibits an appreciable change from the original viscosity, or if there is any sign of gelation. Do not add solvent or thinners to the cement.

D) Installation Procedure

- 1) Cut pipe square with the axis, using a fine-tooth saw with a miter box or guide. Woodworking blades may be used. A rotary cutter may be used if the cutting blades are specifically designed for cutting plastic pipe in such a way as not to raise a ridge (flare) at the end cut of the pipe. The use of a standard rotary metal pipe cutter is not recommended.
- 2) Remove all burrs and break the sharp lead edges.
- 3) Test dry fit of the joint. The solvent cement joint is designed so that there will generally be interference of pipe wall with the fitting socket before the pipe is fully inserted. Insert the pipe into the fitting and check that the interference occurs about 1/3 to 2/3 of the socket depth. Sometimes, when the pipe and fittings are at their tolerance extremes, it may be possible to fully insert the dry pipe into the fitting socket until it bottoms. If this occurs, extra care must be taken to apply sufficient cement to fill the gap between pipe and fitting in order to obtain a strong leak-free joint.
- 4) Surfaces to be joined must be cleaned and be free of dirt, moisture, oil, and other foreign material.
- 5) Keep cement can closed and shaded when not actually in use. Discard the cement when a noticeable change in viscosity occurs, when the cement does not flow freely from the brush, or when the cement appears lumpy and stringy. Keep the brush immersed in cement between applications.
- 6) PVC solvent cement is fast drying and therefore the cement shall be applied as quickly as possible, consistent with good workmanship. It may be necessary for two workers to perform this operation for larger sizes of pipe. Provide adequate ventilation to reduce fire hazard and to minimize breathing of vapors. Avoid contact with skin and eyes.
  - a) First apply primer to the inside surface of the female end. Use a scrubbing motion to insure penetration. Repeat applications as necessary.
  - b) Apply primer to the outside surface of the spigot end to the depth of insertion. Be sure that the entire surface is softened.
  - c) Reapply primer to the inside surface of the female end.
  - d) Immediately apply cement to the pipe spigot end.
  - e) Apply a light coat of cement to the inside of the socket. To prevent solvent damage to the pipe, do not apply an excess of cement and do not apply cement to the pipe/bell transition.
  - f) Apply a second coat of cement to the pipe spigot end.
- 7) Immediately after applying the last coat of cement to the pipe, and while both the inside socket surface and the outside surface of the male end of the pipe are SOFT and WET with solvent cement, forcefully bottom the male end of the pipe in the socket. Turn the pipe or fitting 1/4 turn during assembly (but not after the pipe is bottomed) to distribute the cement evenly. Assembly should be completed within 20 seconds after the last application of cement.



- 8) If there is any sign of drying of the cement surfaces, carefully redcoat the surfaces and assemble. Care should be taken not to disturb or apply any force to previously assembled joints, which can be adversely affected by rough handling.
- 9) After assembly, wipe excess cement from the pipe at the end of the socket. Any gaps in the cement bead around the pipe perimeter may indicate a defective assembly.
- 10) Handle the newly assembled joints carefully until after the set period as follows:

| Temperature Range (°F) | Minimum Set Time |
|------------------------|------------------|
| 60 to 100              | 30 minutes       |
| 40 to 60               | 1 hour           |
| 20 to 40               | 2 hours          |
| 0 to 20                | 4 hours          |

- 11) Weather Precautions
  - a) For high humidity, quick application of primer and cement is essential to minimize condensation of moisture.
  - b) For high temperatures, the surface temperature of PVC surfaces should not exceed 110° F at the time of assembly.
  - c) For low temperature below freezing, solvents penetrate the PVC surfaces more slowly than in warmer weather. Testing on scrap pipe is recommended to ensure the glue will adequately bond to both surfaces.

E) General Installation Notes

- 1) Longitudinal Bending
  - a) The ability of PVC pipe to bend is a significant advantage over rigid pipes. For gasketed pipes, longitudinal bending is done deliberately during construction or may be the result of changes that occur in the pipe-soil system after construction.
  - b) For gasketed pipes, longitudinal bending is accomplished by axial flexure of the pipe combined with deflection of the gasketed joints:
    1. For axial flexure, the minimum bending radius is recommended to be 300 times the pipe OD.
    2. For joint deflection design purposes, joint deflection should be zero; in the field the maximum allowable joint deflection is one degree.
  - c) For solvent-welded pipes, longitudinal bending is accomplished solely by axial flexure of the pipe. The minimum bending radius is recommended to be 200 times the pipe OD. Bending of pipe before cement has gained sufficient strength may weaken joints.
  - d) Where bending is required, it should be done manually. The use of mechanical equipment may cause damage to the pipe or joining system.
- 2) Thermal Expansion and Contraction
 

All materials expand and contract with changes in temperature. Linear expansion of pipe in the longitudinal direction is dependent on:

  - a) Variation in temperature
  - b) 0.36 inch of length variation for every 100 feet of pipe for each 10° F change in temperature.
  - c) For gasketed joints, thermal movement is not a significant design factor as long as the pipe temperatures are kept within accepted limits for PVC pipe, and joints are properly installed with the pipe spigots inserted into the bells to the insertion

line. If spigots are inserted past the insertion line, thermal expansion may cause significant stresses in the pipe bells.

- d) For solvent cemented joints, thermal movement cannot be accommodated in the pipe joints. The following installation procedures are recommended (after the joints are properly cured): the pipe should be installed in straight alignment, and before backfilling restricts longitudinal movement, the product temperature should be adjusted to within 15°F of operating temperature. Where the operating temperature cannot be closely controlled, the stresses resulting from extreme temperature variations must be considered in the design. The design engineer should be consulted for guidance.
- 3) Ultraviolet (UV) Radiation  
Like most plastics, PVC can experience degradation when exposed to UV radiation. This degradation occurs only on surfaces exposed to the sun and penetrates only about .001 inch into the pipe wall. The affected areas often turn a yellow color. When the pipe is no longer exposed to the sun, further degradation does not occur. Ultraviolet exposure does not significantly affect pipe stiffness or tensile modulus properties. However, there is a measurable reduction in values for impact strength. Although pipe may not be damaged by UV radiation, fittings could be damaged and should not be used. If it is questionable as to whether UV damage has occurred, a supervisor should be consulted. PVC pipe's high initial impact strength means that reductions in impact properties due to UV radiation are of little concern. If good construction practice is followed in unloading, handling, and installation, pipe breakage due to impact loads will not be a problem.
  - 4) Thrust Restraint  
The large thrust forces exerted in water distribution systems require thrust restraint designed to resist test pressures as well as peak operating pressures.
    - a) When concrete thrust blocks are used, the size and type of blocking must be based on the maximum thrust force expected and the load-bearing capacity of the soil.
    - b) When mechanical thrust restraint devices are used, they must be a type that is specifically designed for use with PVC pipe.

## 6.6 Pipe Filling & Testing

- A) These precautions should be followed during filling:
  - 1) The line should be filled slowly, with flow velocity not to exceed 2 fps (0.6 m/sec).
  - 2) If possible, the line should be filled at its lowest point.
  - 3) During filling, all air should be expelled through permanent air vents at all high points. If permanent air vents are not required, the installer should install corporation stops at all high points to expel air during initial filling and during pressure testing.
- B) Water pipe installations are tested for pressure and leakage. PWPipe recommends simultaneous pressure and leakage test. If PWPipe is not used, follow the recommendations of the approved equivalent. If the tests are to be done separately, the pressure test should be done first. It is good installation practice to test portions of a line as they are completed. Sections that fail to pass testing should be located, repaired, and

retested until tests are passed. Prior to the start of testing, the following steps are required:

- 1) The pipe to be tested should be backfilled to prevent movement while under test pressures.
- 2) At fittings, permanent thrust restraint is required sufficient to withstand test pressures. If concrete thrust blocks are used, the concrete must be allowed to cure before testing begins.
- 3) Test ends are to be capped and braced to withstand forces developed by test pressures.

## 6.7 Pipe Backfill & Compaction

- A) The maximum earth load on flexible pipe is the weight of the material directly over the pipe (prism load). Unlike rigid pipe, the width of the excavated trench does not affect pipe loading. Trench width is based solely on practical and economical construction.
  - 1) Initial backfill is placed to protect the pipe from impact damage during final backfill.
  - 2) Since initial backfill provides little additional structural support, special compaction is not required.
  - 3) The material used for final backfill need not be as carefully selected as material in the embedment zone, but should not contain boulders, frozen clumps or rubble which could damage the pipe. Excavated material such as debris and removed pavement is not suitable for trench backfill.
- B) If saturation methods are used for compaction, the following recommendations should be followed:
  - 1) Prevent flotation of the pipeline.
  - 2) Do not use saturation during freezing temperatures.
  - 3) Exercise care to prevent erosion at pipe sides and bottom caused by water jetting.
  - 4) Apply only enough water to provide complete saturation.
  - 5) Allow each layer to dewater and solidify until it will support the weight of workers.
- C) Compaction equipment
  - 1) Avoid contacting the pipe with compaction equipment.
  - 2) Do not use compaction equipment directly over the pipe until sufficient backfill has been placed to prevent damaging or disturbing the pipe.
  - 3) Compaction. Under open fields, natural compaction should be adequate. Under improved surfaces, special compaction (as specified by the design engineer) is required.

## 6.8 PVC Pipeline Repair

- A) Pipeline Shutdown and Access
  - 1) If the pipeline is being used for deliveries, the system should be shutdown with an authorized from the water department. The headgate should be locked shut to prevent water from flowing into the system.
  - 2) If the pipeline is not being used, a shutdown authorization is not required, however, the headgate should be locked shut to prevent water from flowing into the system.

- 3) The pipeline should be pumped dry from locations such as boxes, stands, vents. If plans show that the leak is at a low section of the pipeline or no structures exist close to the leak, it may be necessary to cut a hole in the pipeline to complete pumping.
- B) Cracked Pipe Repair
- 1) All PVC District pipelines are 27 inches in diameter or less, which requires that all repairs be made from the exterior of the pipeline. PVC pipe may be damaged due to poor backfilling operations, increased soil loading, equipment damage, etc. and should be repaired as follows:
    - a) The crack/leak location should be positively identified and excavated to allow access to the entire crack.
    - b) The pipe should be cleaned free of dirt or debris and should be towed dry.
    - c) A split piece of plastic having a similar diameter as the cracked pipe should be selected. The size and shape of the plastic piece should be such that the plastic will overlap the crack on all edges of at least two inches. The plastic piece should be trial fit.
    - d) An epoxy cement should be selected to glue the plastic repair piece to the existing pipe. The manufacturer specifications should be consulted to determine how the surfaces should be prepared and mated. PVC pipe glue cement should not be used.
    - e) The epoxy should be applied according to manufacturer specifications, the surfaces mated, and large hose clamps used to hold the mated surfaces together.
    - f) The surfaces should be dried according to manufacturer specifications prior to pressurizing the pipe system.
- C) Broken Pipe Section Repair
- 1) Broken pipe sections are normally damaged from large equipment i.e. rippers, auger holes for trees which either break through the pipe or break enough of the material so the above repair is impossible to make. If the repairs can't be made according to (A) above, the following method should be used:
    - a) The broken pipe section should be positively identified and excavated. For 100-foot head PVC pipe, the pipe will be egg-shaped due to the thin wall thickness. The pipe may need to be excavated in both directions so that the PVC can be reshaped circular for the future connections.
    - b) The broken section of pipe should be removed so that the two remaining ends are undamaged and can be used for coupler connections.
    - c) Both pipe ends should be cleaned free of dirt or debris and should be towed dry.
    - d) A slip coupler should be primed and glued to one of the pipe ends.
    - e) A full Gheen coupler should be inserted over the other pipe end so that the end of the pipe and the Gheen are flush.
    - f) A new section of pipeline should be cut so that it fits between the two pipe ends and can be primed and glued into the slip coupler.
    - g) After the joint has sufficiently set, the Gheen coupler should be slid back over the new pipe end and the gaskets secured on both pipe ends. After the Gheen has been trial fit, it should be bolted into position.
    - h) Upon completion of the installation, the glued surfaces should be set according to manufacturer specifications prior to pressurizing the pipe system.

## 7 Gate Installation

### 7.1 CWD Required Gates

CWD will allow installation of stainless-steel canal gates and line gates as manufactured by Fresno Valves and Castings (FV&C) or approved equal which are the following:

- A) FV&C Series 6600 Model 101C Gate - shall be used in any open vented structure. For diameters 24 inches or less, use type “W” pressure gates. For diameters greater than 24 inches, use Model 20-10C. Installation shall be according to both Manufacturer and CWD specifications. All gates shall be installed with a rising stem unless as otherwise directed by CWD’s Engineer.
- B) FV&C YW Line Gate - shall be used in any closed pipeline application where concrete pipe shall be attached to both sides of the gate. Installation shall be according to both Manufacturer and CWD specifications. All gates shall be installed with a rising stem unless as otherwise directed by CWD’s Engineer.
- C) FV&C PW Line Gate - shall be used in any closed pipeline application where plastic pipe shall be attached to both sides of the gate. Installation shall be according to both Manufacturer and CWD specifications. All gates shall be installed with a rising stem unless as otherwise directed by CWD’s Engineer.

### 7.2 CWD Gate Specifications

All gates installed on CWD facilities shall be of the type as discussed in Section 7.1. Any material required for gate refurbishing shall be obtained by Fresno Valve and Castings.

On all gate installations at the heads of CWD canals and pipelines, the gate wheel for Line and Type W gates, and gate frame, for canal gates, shall extend above ground surface to approximately workman’s hip height.

On all gate installations for standard grower turnouts, the gate wheel for Line and Type W gates, and gate frame, for canal gates, shall extend to approximately 36” above ground surface, or an approved height.

For Line and Type W gates, locking tabs shall be installed on the top screw collar to allow the gate to be locked if required by CWD.

### 7.3 FV&C Series 6600 Model 101C Gate Installation

#### A) General Notes

These gates are easily warped during installation, and the following instructions should be carefully followed for correct gate installation. These gates are accurately machined, assembled and inspected before leaving the factory. Seats are machined to make proper metal-to-metal contact. The space between the seating face was adjusted to less than four thousandths (0.004) of an inch, approximately the thickness of a sheet of paper. Since only one wedge per side is used on these models and they are relatively

light, the seating faces may open up in shipment. If these installation instructions are carefully followed, the gate will operate properly.

B) Installation Instructions

- 1) Locate and layout horizontal and vertical center of pipe opening in the structure where the gate is to be mounted and locate the horizontal and vertical center of the gate opening on the gate frame. An alternative would be to place a piece of plywood against the gate and drill holes at the anchor hole locations. This template could then be used in the structure to mark the location of the anchor holes to be drilled in the structure.
- 2) Layout location of anchor holes by measuring from the horizontal and vertical centers as determined from actual measurements from the gate, or by using the template as discussed above. Mark or punch locations in the structure wall.
- 3) For valves 16 inches in diameter or less, drill (rotary hammer) a 5/8-inch diameter by 2-inch deep hole at each marked location. For valves larger than 16 inches, drill (rotary hammer) a 7/8 inch by 2-inch deep hole. During drilling, care should be taken to keep bit perpendicular in both directions to the future gate frame.
- 4) Remove concrete powder from each hole and insert drop-in expansion anchors or an approved equivalent.
- 5) Install an all thread stud of the appropriate diameter per step (3) in each hole and tighten until the anchor is snug. Care should be taken that the stud is not over-tightened, or threads stripped.
- 6) Install one nut on each thread and run each nut until the nut is approximately 1 inch from the wall or structure.
- 7) Install, dry fit, valve onto the anchored all thread studs and install a nut on each thread so that a nut is behind and in front of the gate at each stud. Adjust, plumb, the valve by loosening and tightening the required nuts so that the gate vertically true and verify by using a carpenter's level.
- 8) Before removing the gate, mark any exposed threaded stud beyond the nut so it may be removed before the valve is reinstalled.
- 9) Remove the outside nuts and valve and leave the inside nuts at the location where the gate was plumbed per step 7. Wire brush the surface between and around the studs and also the mating concrete surface where the gate will be mounted to insure a clean bondable surface.
- 10) Remove any excess threaded stud material before reinstalling the gate and chase and deburr the studs before installing the gate.
- 11) Reinstall the valve and tighten the bolts so that the seal is compressed snugly to the concrete surface.
- 12) Open the gate to check for a smooth transition from the inside of the valve to the face of pipe using mastic if necessary.
- 13) If the gate frame or stem is longer than 4 feet, support anchors/bracing should be installed 12 inches below the top of structure to prevent the gate from swaying.

## 7.4 FV&C Type YW & PW Line Gate Installation

A) General Notes



All line gate housings are cast, and therefore, caution should be used during transport and installation to ensure that the housing does not crack. All gates shall be installed in protector/access stands which will allow access to the gate for maintenance and protection against equipment damage.

During opening and closing of any line gate, it is likely that air will be trapped on either side of the gate so vents should be installed on both sides of the gate, and if PVC pipe is used, prefabricated tees will be required for all vents.

B) Installation Instructions

- 1) The gate location should be located by verifying stationing on the pipeline plans or by location by CWD's surveyor. The location should be excavated to a minimum of 12" below the pipe flow line to allow for construction of a support pad and the gate housing below the pipe flow line.
- 2) The pad location should be compacted and prepared per Section 1.
- 3) The pad shall contain reinforcement consisting of #4 rebar on twelve-inch centers in perpendicular directions. The reinforcement shall be placed and tied on mortar blocks so that the reinforcement is elevated above the bottom of trench a minimum of three inches.
- 4) All surfaces against which concrete is to be placed shall be free from standing water, mud, and debris and shall be firm enough to prevent contamination of the concrete by earth or other foreign material. At the time of concrete placement, all soil adjacent to the pipe shall be sufficiently wet so that it does not absorb water from the concrete or expand upon additional wetting.
- 5) The base shall be constructed in one placement. The concrete shall be rammed and tamped until it has been consolidated to the maximum practicable density and properly conforms against the reinforcement. The concrete shall be troweled to provide a smooth and level surface for gate and protector stand installation.
- 6) The pipe that the gate is to be installed on should be installed and verified that the grade and elevation is per plan. For concrete pipe, the pipe face should end at the gate location. For PVC pipe, the pipe face should be cut 5 feet short to allow for installation of the prefabricated tee and PVC vent.
- 7) For PVC pipe, the prefabricated tee should be installed, and a short piece of PVC pipe installed so that the gate is installed at the correct location.
- 8) The gate should be trial fit to verify that the gate slides over the pipe O.D., is supported by the pad, and that the wheel extends approximately 2-3 feet above surrounding grade.
- 9) During the trial fit, the gate should be checked ensure the gate is vertically true in the direction of the pipe and perpendicular to the pipe. When this is established, alignment marks should be put on the gate and on the pipe, which can be aligned when the gate is cemented to the pipe.
- 10) The pipe should be wire brushed clean if concrete and primer used for plastic. To provide the best bond, epoxy should be applied to the gate and pipe so when the two are joined epoxy flows and fills the gate insert for the pipe. The gate should then be secured to pipe to allow adequate drying of the epoxy.
- 11) After the pipe and gate are bonded, the pipe and vents can be installed on the opposite side of the gate in reverse order as described above.

- 12) Based on the pipe diameter, holes should be cut in the protector standpipe so that holes will straddle the pipe when installed. The standpipe should be placed on the pad and should not be grouted to the pad or pipe which will allow the stand to drain. The pipe stand should be installed so that the top finish elevation is approximately 2-3 feet above surrounding grade.
- 13) The stand should be backfilled with clean sand up to the bottom of the split bell housing which will allow for removal of the gate shutter for maintenance or repair purposes.
- 14) A bolt down expanded metal cover should be installed per CWD specifications on stand. The cover should also include support brackets to prevent the lid from concaving and also provide support for the rising stem to prevent it from wobbling.
- 15) Depending on the stand diameter, the vents should either be installed inside the stand, however, in most situations, the vents will be outside of the stand and should be secured to the stand with metal brackets.

## 7.5 Maintenance and Replacement

- A) All CWD gates will require some periodic maintenance which should be performed according to the following:
  - 1) Exposed non-operating surfaces that are not galvanized should be coated with a waterproof paint designed to withstand the operating conditions prevailing at the particular installation.
  - 2) FV&C 101C gate rails and Type W Stems should be replaced with new galvanized material if the rails or stems are damaged, rusted, or if the gate is removed from a structure and replacement is considered to be proactive maintenance.
  - 3) If material is required which requires purchases from the manufacturer, a material request form shall be written and submitted to the supervisor.
  - 4) All gates shall be operated with a dry stem except for gates which have not been operated for a period of time. In cases where lubricant is needed for gate operation, a silicon spray shall be used-which will prevent the accumulation of dirt, dust, and debris on the stem.
- B) In situations where repair of a gate will require several new parts(i.e., shutter, rails, stem, etc.), it may be less costly to purchase and install a new gate rather than paying for new parts and labor to reconstruct the gate. If a repair fits this category, the supervisor should be contacted to confirm the purchase and installation of a new gate. If a new gate is installed, the old gate should be disassembled and all parts which are in good condition salvaged.

## 8 OSHA Requirements

- A) CAL-OSHA safety requirements shall be in effect during all construction. Special safety precautions shall be taken when working in the vicinity of gas, oil, and/or electrical lines.
- B) It is the responsibility of the contractor to comply with California Government Code 4216, as applicable.



- C) To obtain an Underground Service Alert (USA) Identification Number, Call (800) 227-2600 at least two working days before digging underground.
- D) All excavations and shoring requirements shall conform to OSHA Code 1541.1, Requirements for Protective Systems.
- E) An excavation shall be protected from cave-ins by an adequate protective system which shall have the capacity to resist without failure all loads that are intended or could reasonably expected to be applied to the protective system except if the one of the following conditions is met:
  - 1) The excavation is made in entirely stable rock.
  - 2) The excavation is less than 5 feet in depth and examination of the ground provides no indication of potential cave-ins.
  - 3) The excavation is sloped at an angle not steeper than 1.5:1 horizontal vertical or 34 degrees measured upwards from the horizontal. If the excavation has steeper angles, it may be necessary to construct slopes and benches to avoid potential cave-ins.
- F) Sloping and Benching shall be required to prevent cave-ins in excavations where soils show evidence of distress as evidenced by development of fissures in the face or adjacent to the excavation, the subsidence of the edge of excavation, the slumping of material from the face or the bulging or heaving of material from the bottom of the excavation, the spalling of material from the face of excavation, or material suddenly separating from the face of an excavation. If the excavation appears to be distressed, a supervisor should be consulted, and if necessary, an engineering plan designed for the excavation.
- G) The OSHA Code for this section should be used which provides specific shoring plans based on depths and types of soil.

## 9 Develop Procedures & Requirements

### 9.1 Development Procedure Involving Urban, Commercial, and Industrial Development

In an effort to protect the interests of and reduce future liability to the District the following procedures and requirements have been established.

When properties adjacent to, or potentially impacted by, canals or pipelines owned by the District are proposed for urban, commercial, or industrial development, every effort will be made to ensure the future safe and efficient operation of the District's distribution system. The District will consider development proposals and may request that the approving agency impose certain requirements to mitigate or eliminate the impacts on District facilities and constituents. The imposition of any requirements, conditions, or specifications on any proposed development will be based on one or more of the following reasons:

1. The District incurs greater liability from improvements adjacent to its facilities. Should an open canal or pipeline break or overtop, homes, yards, and streets would be flooded where pasture/vacant land existed in the past. Damage from

- flooding to pasture/vacant land is typically minimal, while damage to residential areas could quickly result in claims of many thousands of dollars. The greater liability and increased costs arise only because development is encroaching upon lands where the District has historically operated its facilities.
2. The District's maintenance and associated costs will be increased. As open canals naturally move over time, prescriptive easements move along with them. Thus, the District is only required to occasionally spray for weeds and maintain a drivable bank. Open canals which traverse through documented easements, on the other hand, require a higher level of maintenance, such as repairing natural erosion to the inside of the banks, in order to keep the canal within the documented easement while still allowing room for workers and equipment to access the canal. When considered with the additional maintenance due to greater liability, the increase in cost can be significant. In locations where pipelines exist, the impact from adjacent development can cause significant impact, requiring additional maintenance. The difficulty in accessing pipelines in developed areas further increases the cost.
  3. General canal safety will be improved. It is the District's experience that the number of children playing in or near open canals increases with new developments that are built adjacent to or near the District's facilities. Not only will required lining or piping of the canal help to control the District's maintenance and associated costs, it will also greatly increase the safety of all persons that new development will bring into the area. Should a person accidentally fall into an unlined canal, it would be difficult, at best, for the person to extricate himself or herself from the canal. Canal banks are inherently muddy and slippery, usually with no readily available handholds or footholds. Lining of canals eliminates this condition in the areas where lining is placed. The District requires ladders to be built into the lining at both ends, thus providing relatively easy places at which persons may rescue themselves.

Therefore, to mitigate impacts and properly allocate the burdens associated with development, the following process shall be implemented:

1. The owner/developer will submit to the appropriate governmental agency (i.e., City of Chowchilla, County of Madera, County of Merced) a request to develop the particular parcel. Notification of the proposed development will be made to the District by the permitting agency. The District will review the project to determine if there are any impacts to the District's distribution system or natural waterways used by the District to convey irrigation water and notify the appropriate agency.
2. Preliminary briefing meeting(s) shall be held between the owner/developer and the owner/developer's architect and/or engineer to discuss the pertinent factors concerning the feasible and rational alternatives concerning the development. These meetings could include District staff to assist in providing acceptable alternatives for incorporating District facilities into a development to meet the needs of the owner/developer and the District.
3. Preliminary design meetings shall be held between the owner/developer, the owner/developer's architect or engineer, and District staff to outline District procedures and policies which may pertain to the project. Based on a risk analysis by the District Engineer, replacement of the existing pipelines or piping/lining of open canals may be required. During the course of these meetings, the District will need adequate time to

- analyze the impact on the affected facility based on system demands and any proposed relocation to accommodate the development. After the facility has been analyzed, the required easement can be determined according to CWD Standard Specifications and Drawings, which the owner/developer and their architect or engineer will need to incorporate into the development. If replacement of existing pipelines or piping/lining of open canals is required, the following conditions will apply:
- A) Re-piping of Existing Pipelines  
Many of the District's existing pipelines are of older pipe that will not hold up to the impacts associated with development and surrounding construction activity. If this is deemed to be the case, the pipeline shall be replaced with a new pipeline. All current District Standard Specifications and Drawings dealing with piping shall apply.
  - B) Piping of Open Canal  
If the canal is of a capacity which can be accommodated by a pipeline having an inside diameter of 84 inches or less, the canal shall be piped. Under certain circumstances, the District may elect to participate in piping a canal with a capacity requiring an inside diameter in excess of 84 inches. All short runs of open canal created from the relocation of canal shall be piped. All current District Standard Specifications and Drawings dealing with piping shall apply.
  - C) Parcel Splits  
In the event development requires District parcels with existing turnouts to be split, new turnouts shall be constructed to serve split parcels. All current District Standard Specifications and Drawings dealing with piping shall apply.
4. At such time as the owner/developer, their architect or engineer, and District staff have agreed upon a preliminary development plan and District facility plan, the following items should be submitted to the District:
    - A) Fees according to the District's project agreement and/or current fee schedule.
    - B) Preliminary title report which shows current ownership and property description.
    - C) Cost estimate for all work proposed on the District's facility prepared by a registered engineer.
    - D) Legal description of property and pipeline easement on 8"x11" paper that is preapproved by the District and prepared by a registered land surveyor.
    - E) A recordable 8"x11" drawing of the new easement prepared by a registered engineer or surveyor.
    - F) A copy of any applicable design drawings, tract map, parcel map, site plan, street plan, etc. for review and approval by the District.
  5. District staff will review and comment on the plans, easements, estimates, etc. for the project. Timing of the District review and approval will be dependent upon staff workload and the size of the project.
  6. District staff will prepare the requirements for the development dependent on staff workload and the size of the project.
  7. After the necessary agreements and requirements have been signed and recorded, the District's Engineer will sign all construction plans related to the relocation of the District's facility, and the owner/developer will be authorized to begin construction on the District facility.

8. The owner/developer's contractor shall contact the District and shall secure a permit prior to commencement of work, which shall include the contractor's construction schedule.
9. After the contractor has completed all work, the District will make a final inspection of the project and accept the project if all work has been completed in accordance with approved plans. The owner/developer shall provide the District with the following:
  - A) Maintenance bond guaranteeing maintenance of the facility and appurtenances for a one-year period following the date of acceptance.
  - B) A policy of title insurance guaranteeing the facility easement and proper title to the District.
10. Following the one-year maintenance period, the District will release the maintenance bond provided all necessary maintenance has been completed. From that point on, the District will maintain the facility.
11. The development agreements referenced hereinabove are limited to a maximum of one year. Extension of development agreements may be given in periods of up to one year. Extension of an agreement will require a review of both design drawings and the existing agreement to ensure that all terms and conditions are consistent with current CWD Standard Specifications and Drawings. A fee for extension of an agreement will be charged as required.

## 10 General Engineering & Maintenance Concepts & Procedures

### 10.1 Engineering Concepts

A) Private vs. CWD Facility Determination

Engineering department has prepared and continues to update service area and facility maps which show which pipe/canal facilities are owned, operated, and maintained by the District and which facilities are private. If work is requested or ordered on facility which could be private, a supervisor should be called to the location to verify who owns the facility, and if necessary, engineering should be contacted to verify ownership.

B) Road Closures, Culvert Replacements within Road Right-of-Ways, Compaction Tests

The District is continually working with other street maintaining agencies to replace and upgrade existing culverts which benefits both the District and the street agency. In all cases, ASTM C-361 pipe will be used and is purchased and delivered by the street maintaining agency. The District will use its forces to install and backfill the pipeline. A typical road crossing will consist of the following steps:

| Item | Agency   | Work Description                                                   |
|------|----------|--------------------------------------------------------------------|
| 1    | District | Engineering investigation of existing utilities.                   |
| 2    | Street   | Street Maintaining Agency issuance of a no-fee permit to District. |
| 3    | District | USA Check of Utilities within the culvert replacement relocation.  |
| 4    | District | Removal of the existing culvert.                                   |

|   |          |                                                                 |
|---|----------|-----------------------------------------------------------------|
| 5 | Street   | Purchase and delivery of new pipe by street maintaining agency. |
| 6 | District | Installation of pipe by District.                               |
| 7 | District | Backfill and compaction of pipeline by District.                |
| 8 | Street   | Compaction test completed by street maintaining agency.         |
| 9 | Street   | Repaying of road by street maintaining agency.                  |

- C) Prior to the start of any project, the plans should be reviewed on site by the crew leader and engineer, and between the crew leader and crew to assign specific tasks and a daily work schedule. The plans should accurately show all project features and the scope of the proposed work. However, items such as turnout tailpipe or pipe flow lines at outlets may not be exactly as shown on the plans since these items are not potholed prior to start of work. If discrepancies exist between field conditions and plans, a supervisor and engineer should be contacted to discuss various options.
- D) The signature of the CWD Engineer on drawings constitutes District approval of the same as to the engineering aspects thereof and does not authorize, expressly or implicitly the construction of any aspect hereof or the interference with any property, equipment, or interest of CWD. No such construction or interference shall occur until the District has obtained, by separate agreement such agreements as CWD deems necessary for the protection of its facilities.
- E) All work to CWD facilities and/or within the CWD right-of-way requires an approved license agreement (encroachment permit) prior to the start of any construction.
- F) Landowner/developer/contractor responsible for improvements over CWD facilities agrees to assume sole responsibility for the job site conditions during the course of construction of the project, including safety of all persons and property. This requirement shall apply continuously and not be limited to normal working hours.
- G) All construction within the CWD right-of-way shall be done in accordance with the approved drawings and the current edition of the CWD Specifications and Drawings, and Caltrans Standard Specifications. In the event of conflict, the more stringent requirements shall apply.
- H) Where the plans or specifications describe portions of the work in general terms, but not in complete detail, it is understood that only the best general practice is to prevail and that only materials and workmanship of the first quality are to be use.
- I) The District will not be responsible for the, or liable for, unauthorized changes to or uses of the plans. All changes to the plans must be obtained in writing and must be approved by the preparer of the plans.
- J) CWD Standard Details may require modifications based on found field conditions. Such modifications shall be reviewed and approved by the District Engineer.
- K) Construction within the CWD right-of-way will not be allowed during the irrigation season. The start and end of the irrigation season varies annually (typically March to October).
- L) The Contractor shall provide an alternate storm water reroute during construction unless determined otherwise by the District Engineer.

- M) Contact the CWD Engineering Department at least two working days prior to any construction and/or necessary inspections. Work within the CWD right-of-way shall proceed in a continuous manner once started. The District Engineer shall be notified of any work stoppages. Whenever work is to restart, the District Engineer shall also be contacted a minimum of two working days prior to all construction scheduled on a holiday or weekend. CWD phone (559) 665-3747.
- N) The Contractor shall be required to have a pre-construction conference with the CWD Engineering Department, prior to starting any work within the CWD right-of-way.
- O) A set of approved plans and/or encroachment permit shall be on the job site at all times during construction.
- P) Any damages to CWD facilities during construction shall be repaired or replaced in a manner approved by the District Engineer at the sole cost of the Contractor.
- Q) From time to time, it may be necessary to change the work as designed on the plans to simplify construction or complete aspects of the project in less time. If change orders are needed, the engineer for the project shall be consulted, a revised plan/detail drawn and signed by the District Engineer, and the change order delivered to the field. No changes shall be made in the field unless this process is followed.
- R) It shall be the responsibility of the crew leader and crew to make As-Built changes on the plans which show utilities, District facilities, or other items which exist or are installed differently in the field than shown on the project plans. Also, the crew leader should be notifying his supervisor daily of any As-Built changes so those changes can be related to engineering. Any work shall not be deemed complete until the CWD Engineering Department has been provided with a set of As-Built plans in AutoCAD (.dwg) and hard copy formats.
- S) For each pipeline and/or canal, the District has either a prescriptive easement or a recorded easement which requires that public utilities or other private facilities have a permit from the District. The District's permit clearly states that the District has the right to request that these utilities/facilities be removed/relocated if they impact repair, replacement, or installation of District facilities. If it appears that a conflict may exist between District facilities and other facilities, engineering should be contacted to verify a permit is on file and to make contact with the other agency/party. Prior to the start of any work which will require excavating, USA should be contacted, and facilities marked which may be in the immediate area of work.
- T) Most District facilities were constructed and/or installed prior to most road rights-of-ways, and according to California Water Code Section 7034 and 7035, the street maintaining agency is responsible for maintenance, replacement, and repair of the facility within the road right-of-way. The District under these codes is still responsible for keeping the facilities clean of trash, debris, and sand. If work is requested near a road right-of-way, engineering should be contacted to stake the limits of the road right-of-way. If the requested work is within the road right-of-way, engineering will contact the street maintaining agency and coordinate with that agency to have the work completed.
- U) For structure and pipeline installation, line and grade are usually established by control points consisting of stakes, spikes, or shiners set at the ground surface and offset from the proposed centerline of the structure or pipe. When stakes are established at the



surface, batter boards, tape and level, or other instruments are used to transfer line and grade to the trench bottom. Regardless, the basic procedures include:

- 1) Stakes, spikes, plugs or shiners are driven flush with the ground surface, at 100-foot intervals for straight alignment and at shorter intervals for curved alignment.
- 2) Control points are offset 10 feet, or some other convenient distance, on the opposite side of the trench from which excavated material will be placed.
- 3) Control point elevations are determined, and the depth from the control point to the trench bottom or pipe invert is indicated on a guard stake next to the control point. After the stakes are placed, care should be taken not to disturb the stakes until the pipe and/or structure referenced by that stake is completed. If the stake is disturbed, the stake should be replaced by the surveyor.

## 10.2 Standard Easement Width for Open Canals and Pipelines

An act to add Section 22438 to the Water Code, relating to irrigation districts.

Approved by the Governor on July 5, 1989.

Filed with the Secretary of State July 5, 1989.

### LEGISLATIVE COUNSEL'S DIGEST

*Senate Bill SB 891, Vuich. Irrigation Districts: canal easements.*

*Under existing law, an irrigation district may acquire by any means any property or interest in property to carry out its purposes.*

*This bill would declare that whenever any irrigation district is the owner of an easement for an open canal for the transportation of water across lands not owned by it, other than as specified, the district shall have a secondary easement on each side of the open canal for the maintenance, repair, cleaning, operation, and control of the open canal, as prescribed, and would specify related matters.*

*The people of the State of California do enact as follows:*

*SECTION 1. Section 22438 is added to the Water Code, to read:*

*22438. (a) Whenever any district is the owner of an easement for an open canal for the transportation of water across lands not owned by it, other than an easement evidenced by a written grant or judgement providing a legal description of the easement, the district shall have a secondary easement on each side of the open canal for the maintenance, repair, cleaning, operation, and control of the open canal and such other use thereof as may be reasonably be required by the district in exercising those rights and in the maintenance, repair, cleaning, and operation of that easement and open canal with equipment owned by or available to the district for that use at the time the rights are exercised. The duration of the secondary easement shall be for so long as the district, or its successors or assigns, continues to own the open canal easement regardless of what use has or has not been made of the secondary easement.*

*(b) The owner of the land upon which a secondary easement is located, or any lessee of the land, shall have the right to use the surface of the land upon which the secondary easement is located for his or her own purposes to the extent that the use does not unreasonably interfere with the district's ownership or use of the secondary easement, or upon the open canal easement. Any encroachment or obstruction placed or permitted upon the secondary easement by the owner of the land or any lessee of the land, which unreasonably interferes with the secondary easement or the open canal easement, may be*

*removed by the district at the owner's or lessee's expense, or by legal action filed by the district.*

*(c) This section shall not be construed to limit the right of a district or of any person to acquire any easement by prescriptive or condemnation or to enter into a written agreement concerning an easement or secondary easement upon such terms as are agreed upon the parties.*

## GENERAL REQUIREMENTS

The following requirements are to provide a guideline for establishing adequate right-of-way widths for canals and ditches owned, operated, and maintained by the District. Any extraordinary conditions, circumstances, misunderstandings, failure, or refusal of a property owner to accept or comply with the general requirements described below should be brought to the immediate attention of the General Manager.

1. When establishing top of bank width required for operation and maintenance purposes, some existing top of bank widths may be more than required by the District, but in most cases, will be less. Therefore, the right-of-way line should be established in accordance with the requirements for future improvements, operations, and maintenance of the canal.
2. To determine the requirements for top of bank widths, canals and ditches shall be classified into two different categories. First, canals with banks which are not more than one foot (1.0') above the surrounding ground level will be classified in a "cut" category. Second, canals with banks which are more than one foot (1.0') above the adjacent ground level will be classified as "fill."
3. Required top of bank widths shall be measured on a level plane from the inside edge of the canal or ditch bank.
4. Canals with capacity of 50 CFS or more:
  - a) Canals which are in a "cut" or at grade shall require a top of bank width no less than twenty feet (20') wide.
  - b) Canals which are in a "fill" shall require a top of bank width of no less than fifteen feet (15') plus one and one-half feet (1.5') for each vertical foot outside of the bank slope plus an additional two feet (2') to establish the right-of-way line beyond the outside toe of the canal bank. Easement width will be as required or no less than twenty feet (20') from the top inside bank to Right of Way line.
5. Canals with a capacity of less than 50 CFS:
  - a) Canals which are in a "cut" shall require a top of bank width no less than fifteen feet (15') wide.
  - b) Canals which are in a "fill" shall require a top of bank width of no less than twelve feet (12') plus one and one-half feet (1.5') for each vertical foot outside of the bank slope, plus an additional two feet (2.0') to establish the right of way line beyond the outside toe of the canal.
6. Canals with a capacity of less than 50 CFS: (Alternate):
  - a) Canals which are in a "cut" shall require a top of bank width no less than fifteen feet (15') wide.
  - b) Canals which are in a "fill" shall require a top of bank width of no less than four feet (4') plus four feet (4.0') for each vertical foot outside of the bank slope.



- c) On smaller slope-type ditches, it may be necessary to resort to access along and outside the ditch, but in all cases the requirements should be established to prevent encroachments on the right-of-way.
- d) The alternate section cannot be used if the overall width exceeds the standard width and is permitted only when the District operations and maintenance functions do not require a standard road right of way.

The following shall be used by staff in the determination and acquisition of new pipeline easement widths:

| Easement Widths (feet)                        |                 |                  |            |
|-----------------------------------------------|-----------------|------------------|------------|
|                                               | Pipe Dia. ≤ 24" | 24" < Dia. ≤ 36" | Dia. > 36" |
| PVC                                           | 20              | 30               | n/a        |
| RGRC                                          | 20              | 30               | 30         |
| Minimum width adjacent to public right-of-way | 15              | 15               | 20         |

Where the pipeline easement will be contiguous and parallel to a joint use right-of-way such as a "local" public street right-of-way or a "rural" road with a right-of-way 60 feet or less, the required easement may be reduced if the street maintaining agency allows the District to perform maintenance using a portion of the road right-of-way. On any street or rural road where curbside parking will be permitted by the street maintaining agency, the easement width may be reduced.

The easement width may not be reduced for controlled access streets designated as freeways, expressways, super arterials, arterials, collectors, or landscaped drives. No easement reduction will be permitted adjacent to turn lanes or bus stops or other locations posted to prohibit stopping or parking without special provision for maintenance access. Written evidence may be required from the street maintaining agency showing that the predetermined easement width reduction can be satisfied.

Where public utility easements or landscape easements will overlap the District's pipeline easement, regardless of pipeline diameter, the required pipeline easement width shall be increased as necessary so that fifty percent (50%) of the required easement width is free from overlapping utilities. The District may waive this easement requirement for landscape easements if the District can be assured the landscaping will not impact the pipeline.

The required easement for pipelines greater than 72-inch internal diameter shall be determined on a case-by-case basis.

All easements must provide a minimum turning radius for WB-67 (45-foot minimum).

### 10.3 Automation and Supervisory Control and Data Acquisition (SCADA) Notes

- A) All automation and SCADA facilities shall comply with the CWD Standard Specifications and Drawings
- B) CWD's standard control gates for canals and pipelines in outlet structures shall be solar powered, automatic, and capable of remote control. Gates shall be Slipmeter, Slipgate, Flumegate, as manufactured by Rubicon Water, or equivalent.
- C) All new automated gates shall be outfitted with 900Mhz radios as manufactured by Guardian, MDS, Viper, or equivalent. Gate controls and radios shall communicate with and be integrated into the District's SCADA system.
- D) All new trash screens shall be automated inline trash screens using solar panels or overhead electrical power, as manufactured by International Water Screens, or approved equivalent.
- E) Protection for automated gates and trash screens shall be provided with chain link fencing per CWD Standard Specifications and Drawings.

Attachment A – Standard Drawings

**GENERAL NOTES:**

1. THE SIGNATURE OF THE CHOWCHILLA WATER DISTRICT (CWD) ON DRAWINGS CONSTITUTES CWD'S APPROVAL OF THE SAME AS TO THE ENGINEERING ASPECTS THEREOF ONLY AND DOES NOT AUTHORIZE, EXPRESSLY OR IMPLICITLY THE CONSTRUCTION OF ANY ASPECT HEREOF OR THE INTERFERENCE WITH ANY PROPERTY, EQUIPMENT, OR INTEREST OF THE CWD. NO SUCH CONSTRUCTION OR INTERFERENCE SHALL OCCUR UNTIL THE CWD HAS OBTAINED, BY SEPARATE AGREEMENT SUCH AGREEMENTS AS CWD DEEMS NECESSARY FOR THE PROTECTION OF ITS FACILITIES.
2. ALL WORK TO CWD FACILITIES AND/OR WITHIN THE CWD RIGHT-OF-WAY REQUIRES AN APPROVED ENCROACHMENT PERMIT PRIOR TO THE START OF ANY CONSTRUCTION.
3. LANDOWNER/DEVELOPER/CONTRACTOR RESPONSIBLE FOR IMPROVEMENTS OVER CWD FACILITIES AGREES TO ASSUME SOLE RESPONSIBILITY FOR THE JOB SITE CONDITIONS DURING THE COURSE OF CONSTRUCTION OF THE PROJECT, INCLUDING SAFETY OF ALL PERSONS AND PROPERTY. THIS REQUIREMENT SHALL APPLY CONTINUOUSLY AND NOT BE LIMITED TO NORMAL WORKING HOURS.
4. ALL CONSTRUCTION WITHIN THE CWD RIGHT-OF-WAY SHALL BE DONE IN ACCORDANCE WITH THE APPROVED DRAWINGS AND THE CURRENT EDITION OF CWD STANDARDS, CALTRANS STANDARD SPECIFICATIONS, AND/OR UNITED STATES BUREAU OF RECLAMATION STANDARDS AS APPLICABLE.
5. WHERE THE PLANS OR SPECIFICATIONS DESCRIBE PORTIONS OF THE WORK IN GENERAL TERMS BUT NOT IN COMPLETE DETAIL, IT IS UNDERSTOOD THAT ONLY THE BEST GENERAL PRACTICE IS TO PREVAIL AND THAT ONLY MATERIALS AND WORKMANSHIP OF THE FIRST QUALITY ARE TO BE USED.
6. CWD WILL NOT BE RESPONSIBLE FOR, OR LIABLE FOR, UNAUTHORIZED CHANGES TO OR USES OF THE PLANS. ALL CHANGES TO THE PLANS MUST BE OBTAINED IN WRITING AND MUST BE APPROVED BY THE PREPARER OF THE PLANS.
7. CWD STANDARD DETAILS MAY REQUIRE MODIFICATIONS BASED ON FOUND FIELD CONDITIONS SUCH MODIFICATIONS SHALL BE REVIEWED AND APPROVED BY THE CWD ENGINEER.
8. CONSTRUCTION WITHIN THE CWD RIGHT-OF-WAY WILL NOT BE ALLOWED DURING THE IRRIGATION SEASON. THE START AND END OF THE IRRIGATION SEASON VARIES ANNUALLY (TYPICALLY MARCH TO OCTOBER).
9. CONTRACTOR SHALL PROVIDE AN ALTERNATE STORM WATER REROUTE DURING CONSTRUCTION UNLESS DETERMINED OTHERWISE BY THE CWD ENGINEER.
10. CAL-OSHA SAFETY REQUIREMENTS SHALL BE IN EFFECT DURING ALL CONSTRUCTION. SPECIAL SAFETY PRECAUTIONS SHALL BE TAKEN WHEN WORKING IN THE VICINITY OF GAS, OIL, OR ELECTRICAL LINES.
11. IT IS THE RESPONSIBILITY OF THE CONTRACTOR TO COMPLY WITH CALIFORNIA GOVERNMENT CODE 4216, AS APPLICABLE. TO OBTAIN AN UNDERGROUND SERVICE ALERT (USA) IDENTIFICATION NUMBER, CALL (800) 227-2600 AT LEAST TWO WORKING DAYS BEFORE DIGGING UNDERGROUND.
12. CONTACT THE CHOWCHILLA WATER DISTRICT ENGINEERING DEPARTMENT AT LEAST TWO WORKING DAYS PRIOR TO ANY CONSTRUCTION AND/OR NECESSARY INSPECTIONS. WORK WITHIN THE CWD RIGHT-OF-WAY SHALL PROCEED IN A CONTINUOUS MANNER ONCE STARTED. THE CWD ENGINEER SHALL BE NOTIFIED OF ANY WORK STOPPAGES. WHENEVER WORK IS TO RESTART, THE CWD ENGINEER SHALL REQUIRE AN ADDITIONAL TWO WORKING DAYS NOTICE. THE CWD ENGINEER SHALL ALSO BE CONTACTED A MINIMUM OF TWO WORKING DAYS PRIOR TO ALL CONSTRUCTION SCHEDULED ON A HOLIDAY OR WEEKEND. PHONE: (559) 665-3747.
13. CONTRACTOR SHALL BE REQUIRED TO HAVE A PRE-CONSTRUCTION CONFERENCE WITH THE CWD INSPECTOR, PRIOR TO STARTING ANY WORK WITHIN THE CWD RIGHT-OF-WAY.
14. CONSTRUCTION LAYOUT AND INSPECTION TO BE PROVIDED BY THE CWD. A SET OF APPROVED PLANS SHALL BE ON THE JOB SITE AT ALL TIMES DURING CONSTRUCTION.
15. EARTH FILL AND SUBGRADE SHALL BE COMPACTED TO A MINIMUM 90% RELATIVE COMPACTION (ASTM D-1557) WITHIN THE CWD RIGHT-OF-WAY, UNLESS DETERMINED OTHERWISE BY THE CWD ENGINEER.
16. ANY DAMAGES TO CWD FACILITIES DURING CONSTRUCTION SHALL BE REPAIRED OR REPLACED IN A MANNER APPROVED BY THE CWD ENGINEER AT THE SOLE COST OF THE CONTRACTOR.
17. ANY WORK WITHIN THE CWD RIGHT-OF-WAY SHALL NOT BE DEEMED COMPLETE UNTIL THE CWD ENGINEERING DEPARTMENT HAS BEEN PROVIDED WITH A SET OF AS-BUILT PLANS IN AUTOCAD AND HARD COPY FORMATS.



**GENERAL NOTES FOR IRRIGATION WORKS**

SCALE: NOT TO SCALE

**C-1**

PREPARED BY: GJF, PAD

APPROVED BY: BT

DATE ADOPTED: 5-11-2022

SHEET 1 OF 2

**AUTOMATION AND SUPERVISORY CONTROL AND DATA ACQUISITION (SCADA) NOTES:**

1. CWD'S STANDARD CONTROL GATES FOR CANALS AND PIPELINES SHALL BE SOLAR POWERED, AUTOMATIC AND CAPABLE OF REMOTE CONTROL. GATES SHALL BE SLIPMETER, SLIPGATE, FLUMEGATE, AS MANUFACTURED BY RUBICON WATER, OR APPROVED EQUIVALENT. ALL NEW CONTROL GATES SHALL BE OUTFITTED WITH 900MHZ RADIOS AS MANUFACTURED BY VIPER, GUARDIAN, MDS OR APPROVED EQUIVALENT. RADIOS SHALL COMMUNICATE WITH AND BE INTEGRATED INTO THE DISTRICT'S SCADA SYSTEM.
2. ALL NEW TRASH SCREENS SHALL BE AUTOMATIC AS MANUFACTURED BY INTERNATIONAL WATER SCREENS, OR APPROVED EQUIVALENT.

**CHOWCHILLA**  
WATER DISTRICT

GENERAL NOTES FOR IRRIGATION WORKS

SCALE: NOT TO SCALE

**C-1**

PREPARED BY: GJF, PAD

APPROVED BY: BT

DATE ADOPTED: 5-11-2022

SHEET 2 OF 2

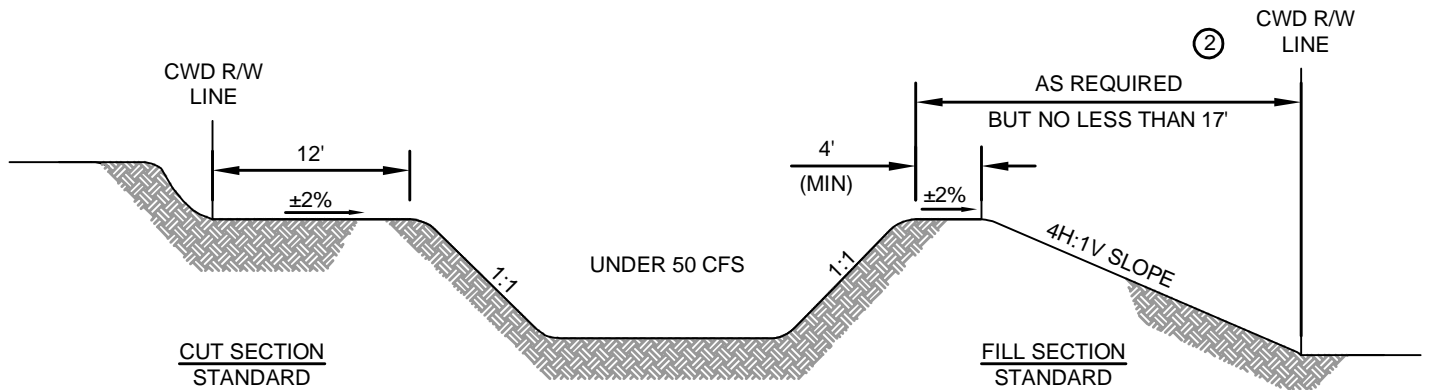
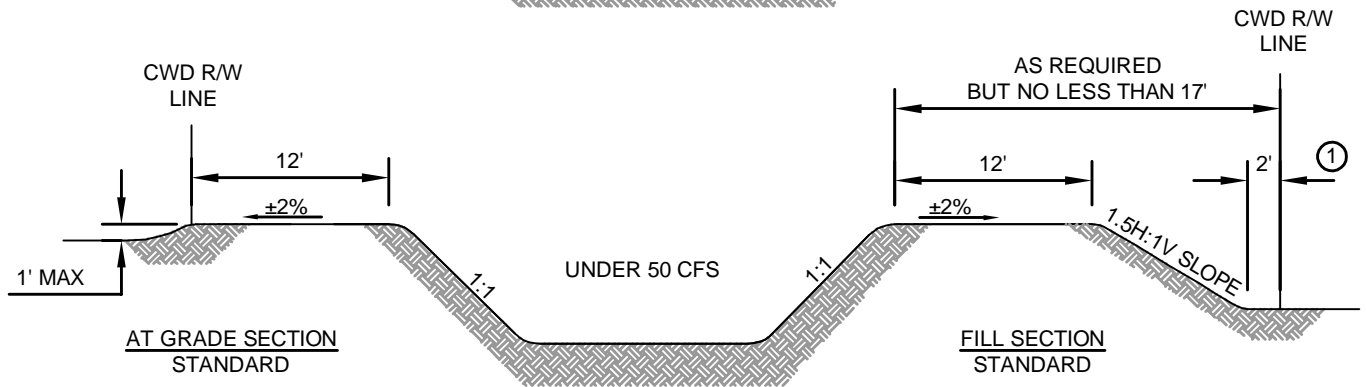
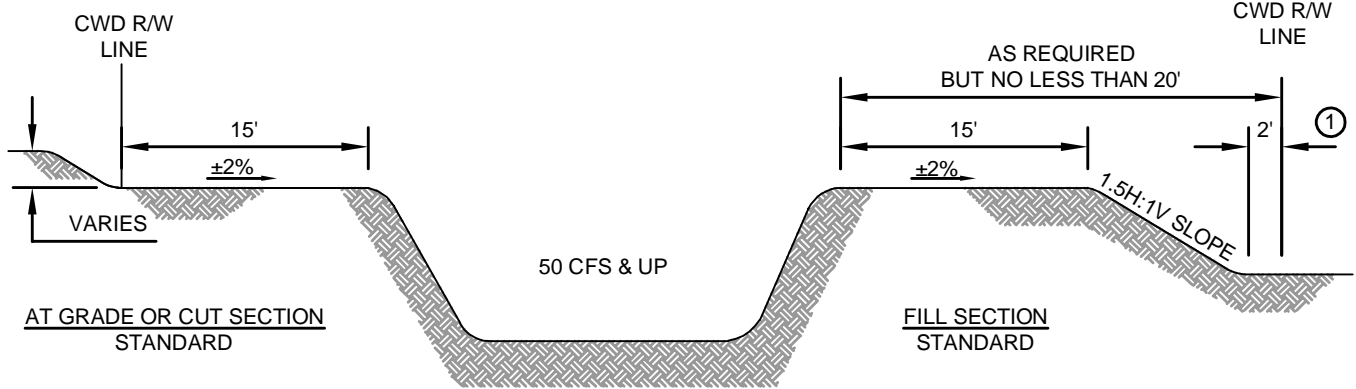

### ALTERNATE

#### NOTES

- ① ADD 2 FEET OF EMBANKMENT WIDTH TO ESTABLISH OVERALL R/W WIDTH TO ACCOMMODATE GRADER BLADE CLEARANCE.
- ② THE ALTERNATE SECTION CAN NOT BE USED IF THE OVERALL WIDTH EXCEEDS THE STANDARD WIDTH AND IS PERMITTED ONLY WHEN DISTRICT OPERATIONS AND MAINTENANCE FUNCTIONS DO NOT REQUIRE A STANDARD ROADWAY.

**CHOWCHILLA**  
WATER DISTRICT

**DISTRICT CANAL RIGHT OF WAY  
REQUIREMENTS**

SCALE: NOT TO SCALE

**C-2**

PREPARED BY: GJF, PAD

APPROVED BY: BT

DATE ADOPTED: 5-11-2022

SHEET 1 OF 1

MINIMUM CROSS SECTION REQUIRED ABOVE MAXIMUM HIGH WATER  
FOR CANAL BANK ELEVATED ABOVE ADJACENT GRADE. (SQ. FT)

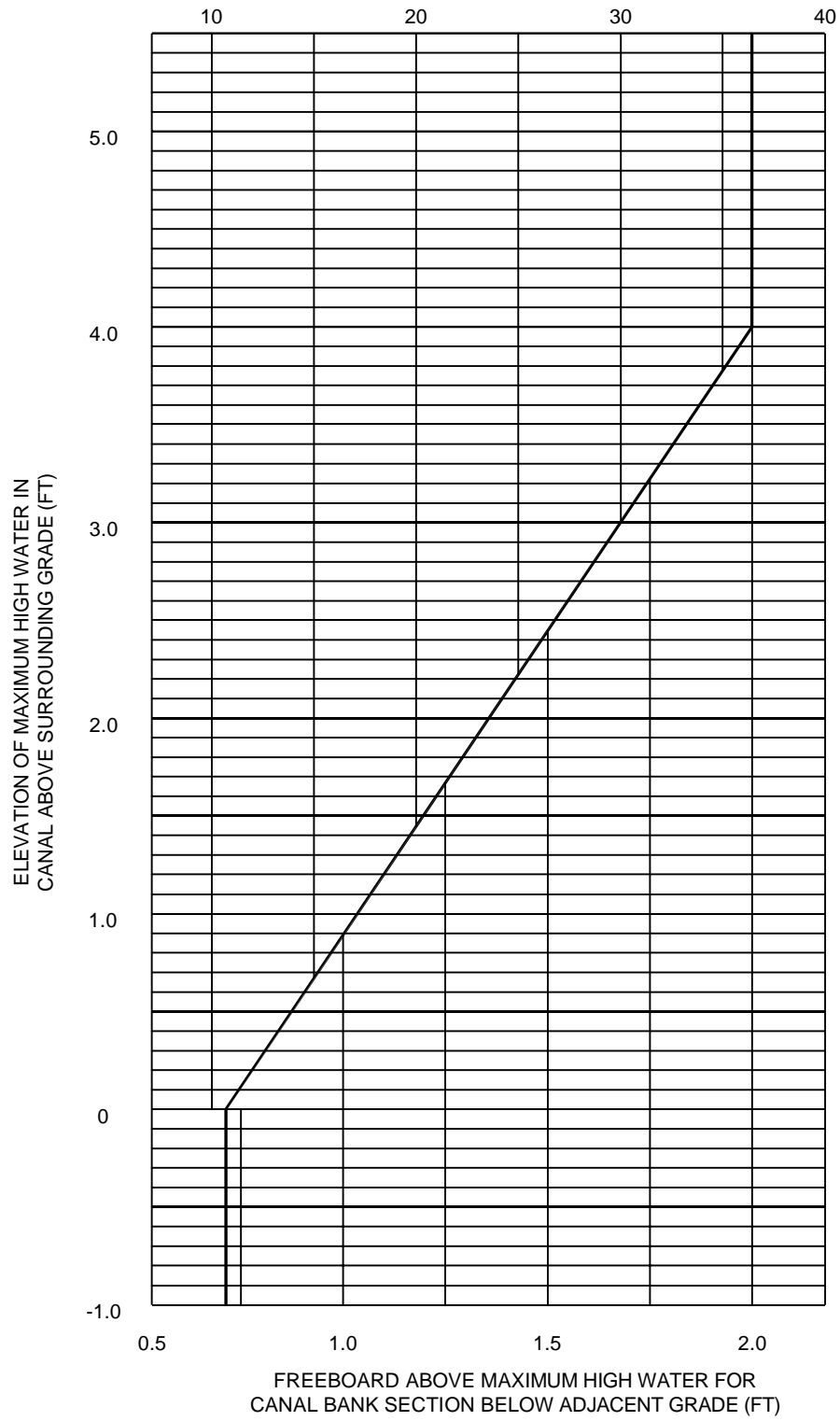

**CHOWCHILLA**  
WATER DISTRICT

**CANAL FREEBOARD REQUIREMENTS**

SCALE: NOT TO SCALE

**C-3**

PREPARED BY: GJF, PAD

APPROVED BY: BT

DATE ADOPTED: 5-11-2022

SHEET 1 OF 1

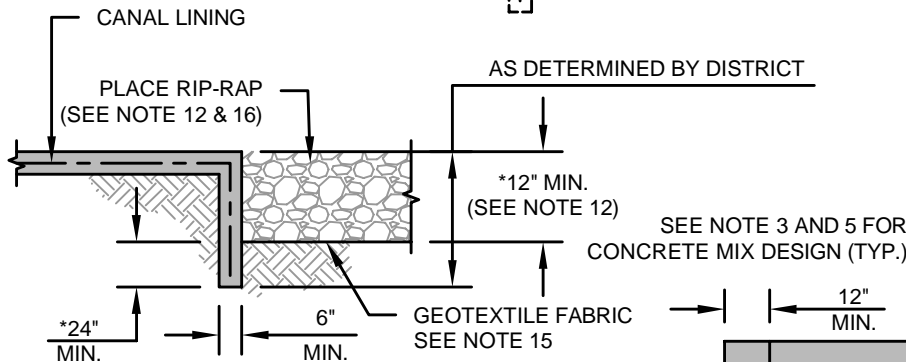
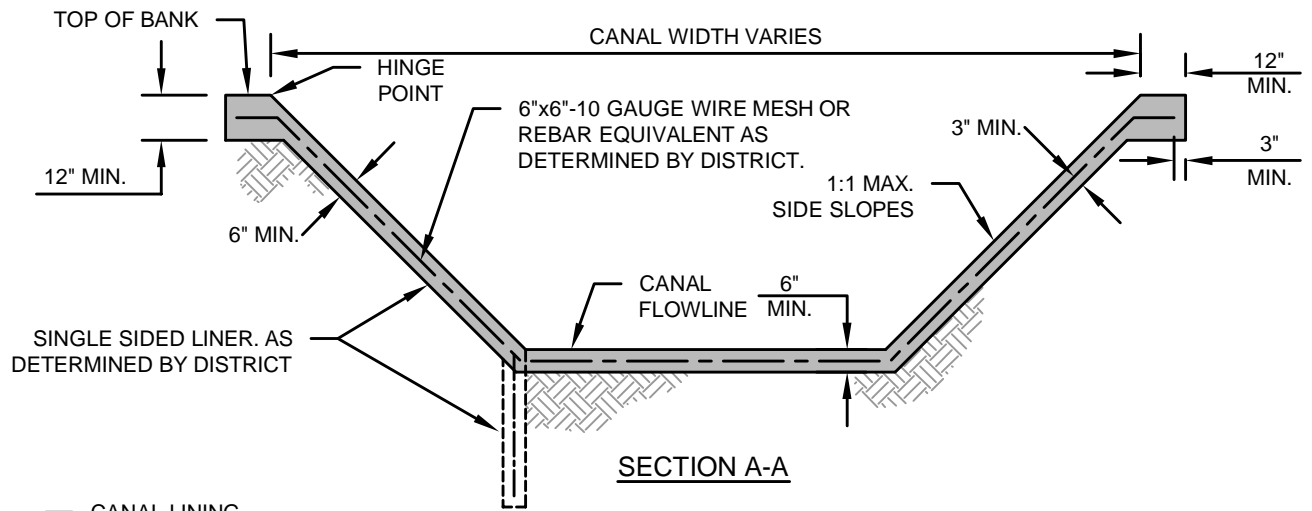

**SECTION B-B  
LINING CUTOFF WALL**

\*MIN. DEPTH SUBJECT TO CWD ENGINEER

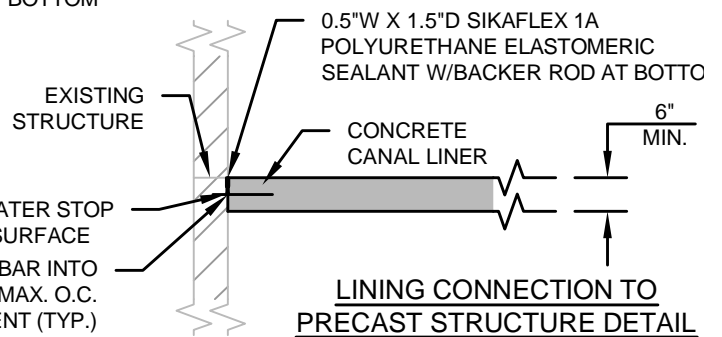
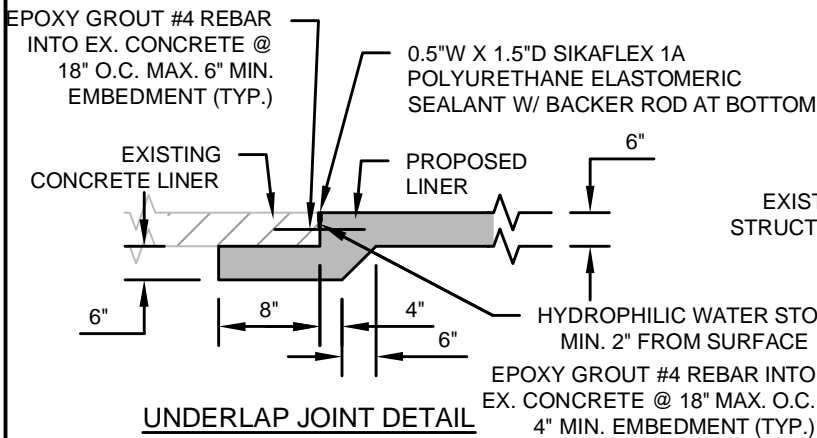
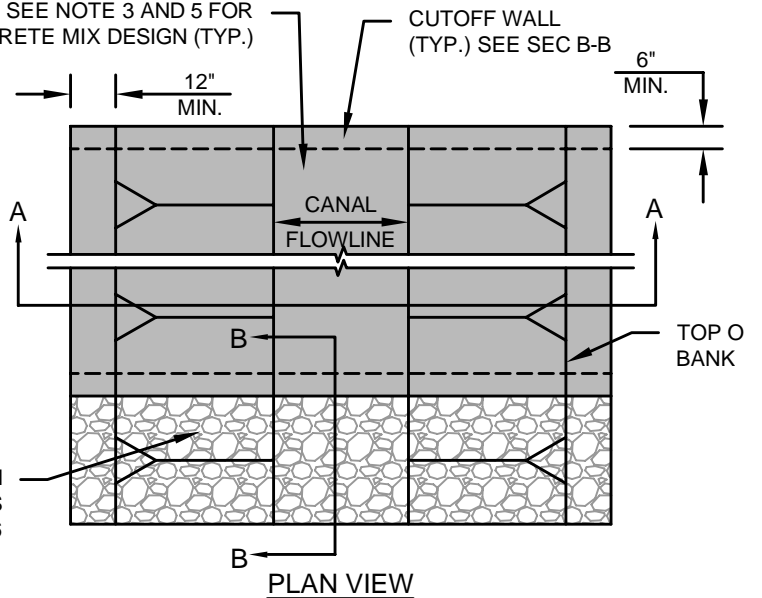

**CHOWCHILLA  
WATER DISTRICT**

**TYPICAL CROSS SECTION FOR CONCRETE LINING**

SCALE: NOT TO SCALE

**C-4**

PREPARED BY: GJF, PAD

APPROVED BY: BT

DATE ADOPTED: 5-11-2022

SHEET 1 OF 2



**CANAL LINING NOTES:**

1. LINING SHALL BE PLACED ON FIRM COMPETENT MATERIAL. IF THE UNDERLYING SOILS ARE NOT SUITABLE FOR CONCRETE PLACEMENT, CONTRACTOR SHALL OVER-EXCAVATE AND REPLACE WITH COMPACTED ENGINEERED FILL.
2. ALL DISTURBED SOILS TO HAVE MINIMUM OF 93% RELATIVE COMPACTION PER ASTM D-1557 IN FILL AREAS FOR A DISTANCE 5 FEET MINIMUM AROUND CONCRETE LINER.
3. CONCRETE LINING SHALL BE 6-1/2 SACK WITH A MINIMUM 28-DAY COMPRESSIVE STRENGTH OF 3,500 PSI.
4. CONTRACTOR SHALL SUBMIT CONCRETE MIX DESIGN TO CWD FOR APPROVAL PRIOR TO CONSTRUCTION.
5. FIBERCAST 500 OR EQUIVALENT CONCRETE FIBER REINFORCED WITH FIBER LENGTHS BETWEEN 1.5 INCH TO 2 INCH. APPLICATION RATE SHALL BE AT A MINIMUM OF 1.5 POUNDS PER CUBIC YARD AND BE INCLUDED IN THE CONCRETE MIX.
6. 6" X 6" - 10" X 10" GAUGE WIRE MESH MAY BE UNCOATED OR GALVANIZED.
7. INSTALL ACCESS/SAFETY LADDERS ON ALTERNATE SIDES OF CANAL 18 INCH ON CENTER AT 100 FEET INTERVALS PER CAL OSHA STANDARDS OR AS DETERMINED BY DISTRICT.
8. LINING CUTOFF WALLS TO BE CONSTRUCTED UPSTREAM AND DOWNSTREAM OF CONCRETE LINING. LINING CUTOFF DEPTH TO BE DETERMINED BY DISTRICT.
9. AS DIRECTED BY CWD'S INSPECTOR OR ENGINEER, CONTRACTOR SHALL MAKE AVAILABLE 7 DAY AND 28 DAY COMPRESSIVE STRENGTH TEST RESULTS.
10. CONTROL JOINTS REQUIRED EVERY 10 FEET IN TRANSVERSE DIRECTIONS WITH CONCRETE JOINT SEAL AND BACKER ROD.
11. CONCRETE LINER REQUIRED FOR A MINIMUM OF 5 FEET IN LENGTH OR LIMITS OF DISTURBED SOIL, WHICHEVER IS GREATER.

**RIP-RAP NOTES:**

12. RIP-RAP REQUIREMENT AS DETERMINED BY CWD ENGINEER AND/OR INSPECTOR.
13. CLASS 2 RIP-RAP WITH METHOD B PLACEMENT FOR A MINIMUM OF 5 FEET PER 2010 CALTRANS STANDARDS AROUND CHANNEL FLOOR AND SIDE SLOPES OR AS DETERMINED BY CWD'S ENGINEER. PLACE WOVEN GEOTEXTILE FABRIC BENEATH RIP-RAP.
14. CUTOFF WALLS SHALL BE EXCAVATED TO A MINIMUM OF 3 FEET BELOW NATIVE GRADE AND 24 INCHES BELOW RIP-RAP SUBGRADE UNLESS OTHERWISE DETERMINED BY CWD'S ENGINEER.
15. WOVEN GEOTEXTILE FABRIC SHALL BE MIRAFI FW500 OR APPROVED EQUIVALENT.
16. RIP-RAP REQUIRED FOR A MINIMUM OF 5 FEET ON UPSTREAM AND DOWNSTREAM ENDS OF CONCRETE LINING.



**TYPICAL CROSS SECTION FOR CONCRETE LINING NOTES**

SCALE: NOT TO SCALE

**C-4**

PREPARED BY: GJF, PAD

APPROVED BY: BT

DATE ADOPTED: 5-11-2022

SHEET 2 OF 2

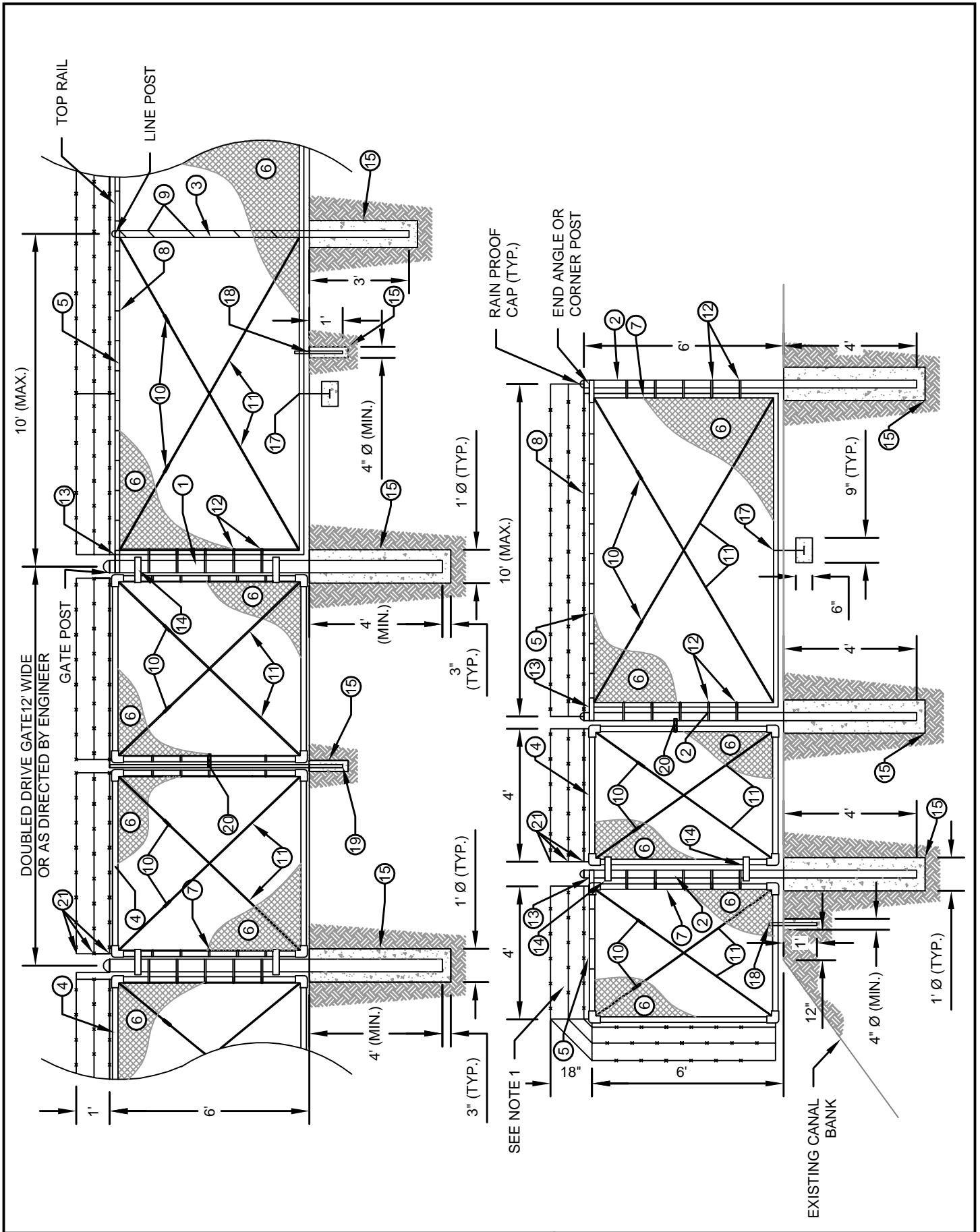

**CHOWCHILLA**  
WATER DISTRICT

**6' CHAIN LINK FENCE GATE DETAIL**

SCALE: NOT TO SCALE  
DATE ADOPTED: 5-11-2022

**F-1**

**FENCING ITEMS TO BE FURNISHED AND INSTALLED**

- |                                                                                                                                                                                                                                                                                                                                                                                                                                                                                                                                                                                                                                                                                                                                                                                                                                                                                                                                                                                                                                                                                |                                                                                                                                                                                                                                                                                                                                                                                                                                                                                                                                                                                                                                                                                                                                             |
|--------------------------------------------------------------------------------------------------------------------------------------------------------------------------------------------------------------------------------------------------------------------------------------------------------------------------------------------------------------------------------------------------------------------------------------------------------------------------------------------------------------------------------------------------------------------------------------------------------------------------------------------------------------------------------------------------------------------------------------------------------------------------------------------------------------------------------------------------------------------------------------------------------------------------------------------------------------------------------------------------------------------------------------------------------------------------------|---------------------------------------------------------------------------------------------------------------------------------------------------------------------------------------------------------------------------------------------------------------------------------------------------------------------------------------------------------------------------------------------------------------------------------------------------------------------------------------------------------------------------------------------------------------------------------------------------------------------------------------------------------------------------------------------------------------------------------------------|
| <p>① 4-1/2" O.D. GALVANIZED STEEL DRIVE GATE POST (10.79 LB/FT)</p> <p>② 2-7/8"Ø GALVANIZED STEEL WALK GATE POST END, ANGLE OR CORNER POST (5.79 LB/FT)</p> <p>③ 2-3/8"Ø O.D. GALVANIZED STEEL LINE POST (3.65 LB/FT)</p> <p>④ 2" O.D. GALVANIZED STEEL GATE FRAME (2.72 LB/FT)</p> <p>⑤ 1-5/8"Ø O.D. GALVANIZED STEEL HORIZONTAL RAIL (2.27 LB/FT)</p> <p>⑥ 2" X 2" MESH X 9 GAUGE GALVANIZED FENCE FABRIC WITH KNUCKLED TOP AND BOTTOM SELVAGE; FENCE FABRIC TO BE GALVANIZED BEFORE WEAVING (GBW)</p> <p>⑦ 1/4" X 3/4" GALVANIZED STEEL STRETCHER BAR</p> <p>⑧ 9 GAUGE (0.148"Ø) GALVANIZED STEEL TIE WIRES OR HOG RINGS AT 15" MAXIMUM SPACING, MINIMUM OF 8 TIE WIRES PER EACH 10' HORIZONTAL RAIL OR TENSION WIRE</p> <p>⑨ 6 GAUGE (0.192"Ø) GALVANIZED STEEL POST CLIPS AT 14" MAXIMUM SPACING MINIMUM, 3 POST CLIPS FOR EACH 4' POST, 5 POST FOR EACH 6' POST</p> <p>⑩ GALVANIZED ADJUSTABLE TURNBUCKLE FOR 3/8" DIAMETER TRUSS ROD</p> <p>⑪ 3/8" DIAMETER GALVANIZED STEEL ADJUSTABLE TRUSS ROD, TRUSS RODS REQUIRED FOR ALL GATE POST PANELS, END OR CORNER POST</p> | <p>⑫ 1/8" THICK GALVANIZED STEEL STRETCHER BAR TENSION BAND AT 12" MAXIMUM SPACING, MINIMUM OF 4 TENSION BANDS FOR EACH 4' POST SECTION AND 6 TENSION BANDS FOR EACH 6' POST SECTION</p> <p>⑬ GALVANIZED RAIL ENDS</p> <p>⑭ HEAVY DUTY MALLEABLE 180° IRON HINGE</p> <p>⑮ CONCRETE FOOTING</p> <p>⑯ 7 GAUGE (0.180"Ø) GALVANIZED STEEL TENSION WIRE</p> <p>⑰ 3/8" X 6" GALVANIZED HOOK BOLT WITH NUT, EMBEDDED IN CONCRETE FOUNDATION MIDWAY BETWEEN POSTS</p> <p>⑱ INSTALL GATE HOLDBACK AT LOCATIONS DIRECTED BY THE ENGINEER</p> <p>⑲ GALVANIZED STEEL PIPE SLEEVE FOR GATE DROP ROD</p> <p>⑳ LOCKABLE LEVER TYPE GATE LATCH</p> <p>㉑ NO. 12 1/2 GAUGE 3-STRAND GALVANIZED BARED WIRE WITH 4-POINT BARBS NO MORE THAN 5-INCHES APART</p> |
|--------------------------------------------------------------------------------------------------------------------------------------------------------------------------------------------------------------------------------------------------------------------------------------------------------------------------------------------------------------------------------------------------------------------------------------------------------------------------------------------------------------------------------------------------------------------------------------------------------------------------------------------------------------------------------------------------------------------------------------------------------------------------------------------------------------------------------------------------------------------------------------------------------------------------------------------------------------------------------------------------------------------------------------------------------------------------------|---------------------------------------------------------------------------------------------------------------------------------------------------------------------------------------------------------------------------------------------------------------------------------------------------------------------------------------------------------------------------------------------------------------------------------------------------------------------------------------------------------------------------------------------------------------------------------------------------------------------------------------------------------------------------------------------------------------------------------------------|

**NOTES FOR FENCING AND GATES**

1. DOUBLE TRUSS RODS ARE REQUIRED IN PANELS ADJACENT TO GATE POSTS AND AT ALL FENCE CORNERS AND END PANELS.
2. ALL GATE CORNERS AND SUPPORT POINTS SHALL BE FASTENED TOGETHER WITH AND REINFORCE WITH MALLEABLE IRON FITTINGS DESIGNED FOR THAT PURPOSE. WELDED CONNECTIONS WILL NOT BE ALLOWED.
3. TACK WELD ALL GATE HINGES AND LATCH COLLARS TO POST.
4. ALL AREAS AFFECTED BY WELDING, TRIMMED ENDS OF BOLTS, STRETCHER BARS, TRUSS RODS OR ANY EXPOSED STEEL SHALL BE PAINTED (GALVANIZED).
5. PROVIDE AND INSTALL GATE HOLDBACK FOR EACH GATE.



**6' CHAIN LINK FENCE GATE DETAIL NOTES**

SCALE: NOT TO SCALE

**F-1**

PREPARED BY: GJF, PAD

APPROVED BY: BT

DATE ADOPTED: 5-11-2022

SHEET 2 OF 2

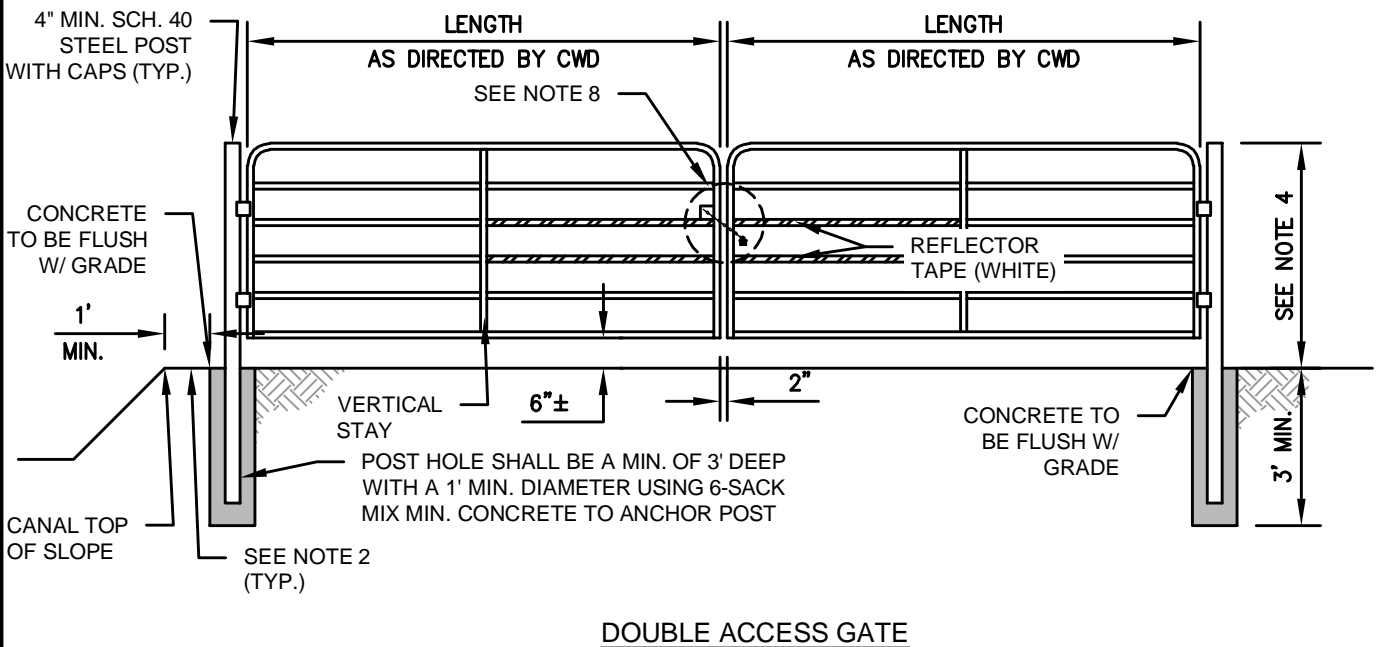
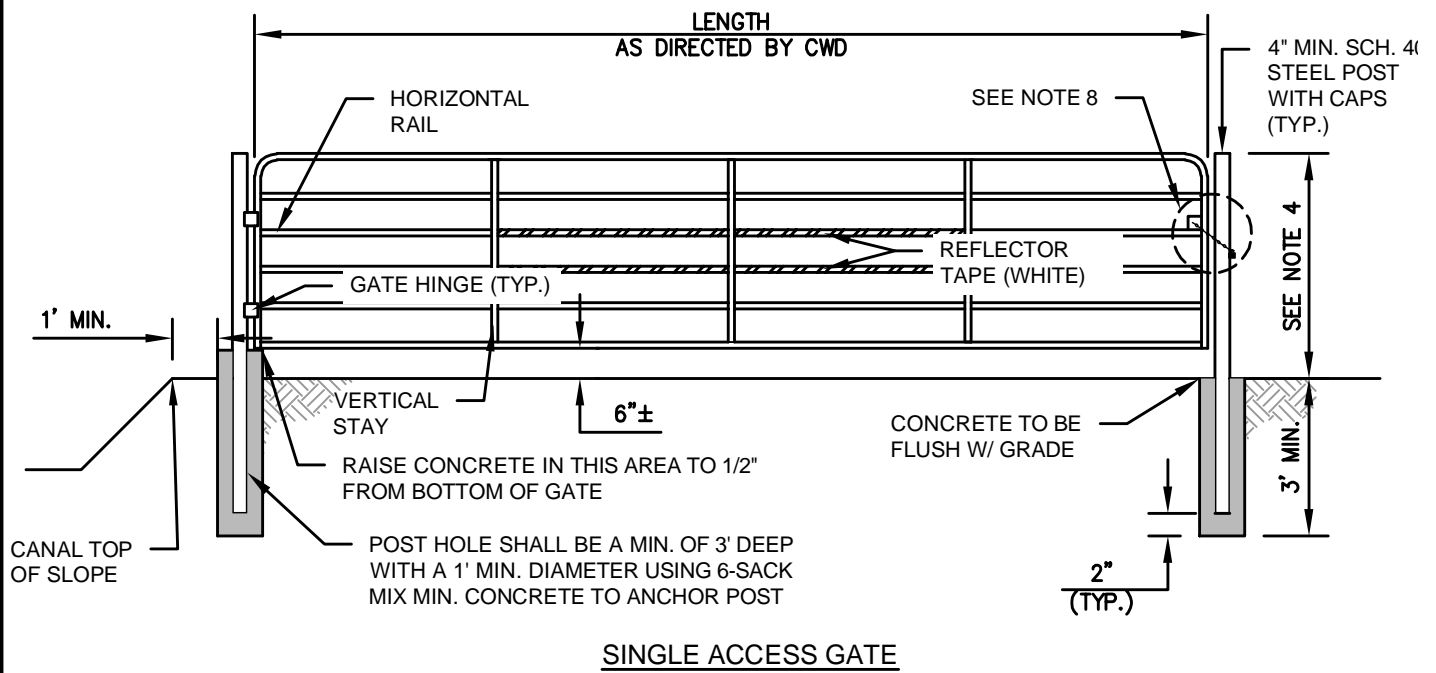

**CHOWCHILLA**  
WATER DISTRICT

**VEHICLE ACCESS GATE RURAL**

SCALE: NOT TO SCALE

**F-2**

PREPARED BY: GJF, PAD

APPROVED BY: BT

DATE ADOPTED: 5-11-2022

SHEET 1 OF 2

GATE SPECIFICATIONS (RURAL PANEL GATES):

1. STRUCTURE PERMIT AND/OR CONSTRUCTION PERMIT IS REQUIRED FOR ALL GATE INSTALLATIONS.
2. LOCATION TO BE VERIFIED WITH CWD INSPECTOR PRIOR TO INSTALLATION.
3. INSTALLED GATE SHALL BE MANUFACTURED BY POWDER RIVER OR APPROVED EQUIVALENT.
4. GATE HEIGHT - 50 INCH MINIMUM.  
GATE WIDTH - AS SPECIFIED IN PLANS OR AS DIRECTED BY CWD.
5. GATE FRAME SHALL BE MADE FROM 1.66 INCH O.D. TUBE, OR LARGER TUBULAR STEEL.
6. GATE SHALL HAVE A MINIMUM OF 5 HORIZONTAL RAILS EVENLY SPACED.
7. GATE SHALL HAVE A MINIMUM OF 2 METAL HINGES.
8. GATE SHALL BE SECURED BY A CHAIN (FURNISHED BY THE LANDOWNER) AND PADLOCK (FURNISHED BY THE DISTRICT).  
AT THE LANDOWNER'S OPTION, ADDITIONAL LOCKS CAN BE INTERLOCKED WITH DISTRICT FURNISHED PADLOCK.
9. VERTICAL STAYS SHALL BE EVENLY SPACED.
10. GATE POSTS WILL BE PAINTED WITH 1 COAT RUSTOLEUM PRIMER AND 2 COATS EXTERIOR RUSTOLEUM (COLOR TO MATCH GATE) OR APPROVED EQUIVALENT. INSTALL OUTRIGGERS AS NECESSARY TO PREVENT 2 WHEEL BYPASS TRAFFIC ON SLOPES.
11. ALL WEEP HOLES SHALL BE FILLED WITH SPRAY FOAM TO PREVENT INSECT INFESTATION.
12. LANDOWNER IS RESPONSIBLE TO MAINTAIN GATE.
13. REFLECTIVE TAPE REQUIRED ON ALL GATES.
14. THESE ARE GUIDELINES ONLY, FINAL DESIGN TO BE PROVIDED BY CONTRACTOR.



VEHICLE ACCESS GATE RURAL NOTES

SCALE: NOT TO SCALE

**F-2**

PREPARED BY: GJF, PAD

APPROVED BY: BT

DATE ADOPTED: 5-11-2022

SHEET 2 OF 2

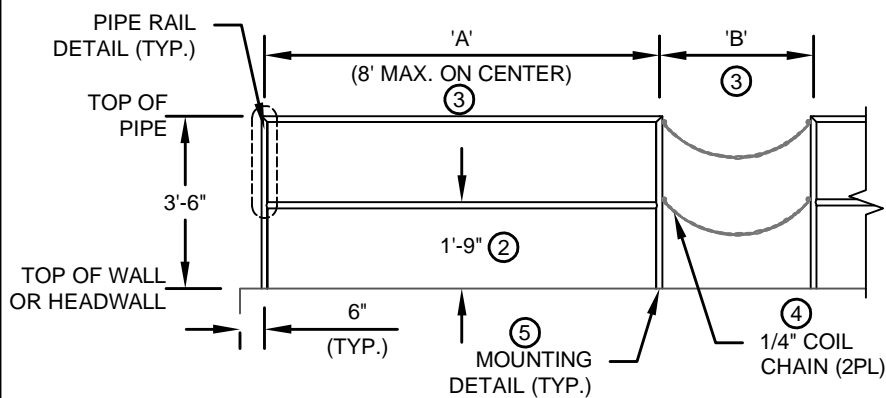

**TYPICAL RAILING SECTION WITH CROSS CHAINS**

NTS

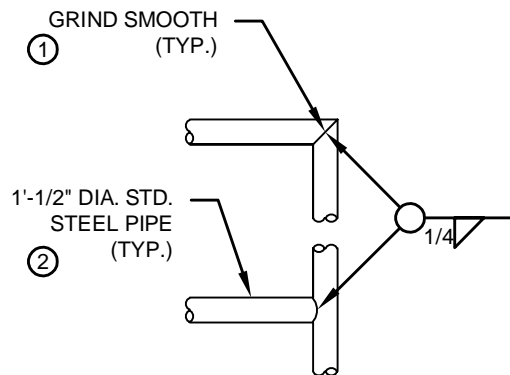

**PIPE RAIL DETAIL** ①

NTS

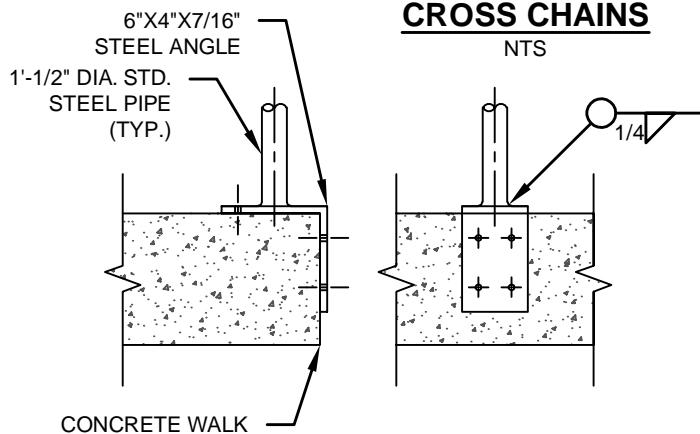

**ANGLE MOUNT DETAIL** ⑥

NTS

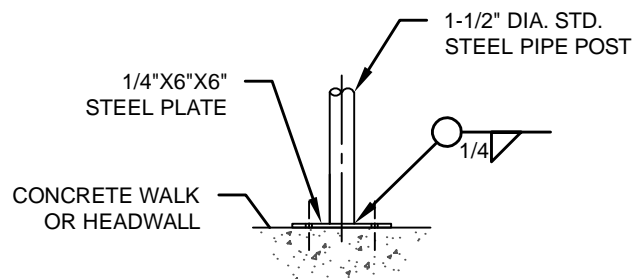

**SQUARE PLATE MOUNT DETAIL** ⑦

NTS

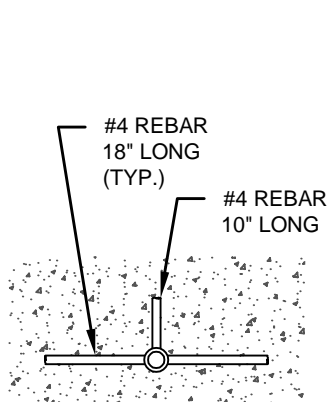

**PLAN VIEW**

NTS

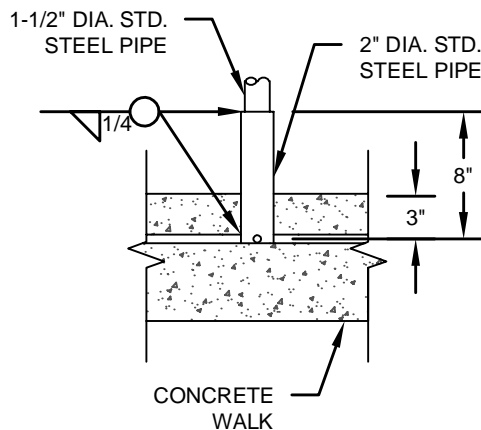

**SLEEVE MOUNT DETAIL** ⑧

NTS

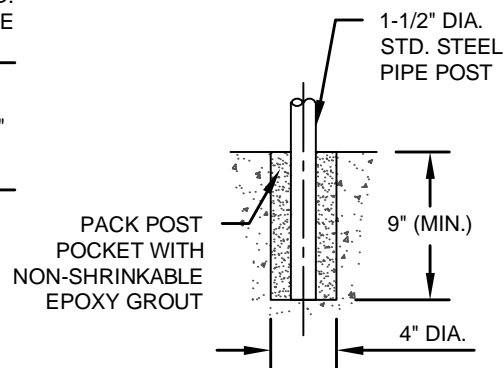

**POST POCKET DETAIL** ⑨

NTS

**CHOWCHILLA**  
WATER DISTRICT

**GUARDRAILS**

SCALE: NOT TO SCALE

**F-3**

PREPARED BY: GJF, PAD

APPROVED BY: BT

DATE ADOPTED: 5-11-2022

SHEET 1 OF 2

**NOTES**

- ① GUARDRAILS SHALL BE INCLUDED ON ALL STRUCTURES WHERE THE VERTICAL FALL DISTANCE EXCEEDS 4'. ALL PIPE FOR GUARDRAIL SHALL BE 1-1/2" NOMINAL STANDARD STEEL PIPE. ALL PIPE TO PIPE CONNECTIONS SHALL BE WELDED AND ALL EXPOSED METAL SURFACES SHALL BE GALVANIZED. WELDS SHALL BE CLEANED WITH WIRE BRUSH AND THEN PAINTED WITH ZINC RICH COLD GALVANIZING, UNLESS THE RAIL HAS BEEN HOT-DIPPED GALVANIZED.
- ② THE CWD RAIL SHALL BE LOCATED APPROXIMATELY HALFWAY BETWEEN THE TOP RAIL AND THE TOP OF THE WALKWAY OR HEADWALL.
- ③ DIMENSIONS 'A' AND 'B' TO BE DETERMINED AND SPECIFIED BY THE CWD ENGINEER.
- ④ CHAIN SHALL BE 1/4" DIAMETER GALVANIZED COIL CHAIN. WELD CHAIN TO GUARD RAILING ON ONE SIDE AT LOCATION AS SPECIFIED ON DRAWING. ATTACH 1/4" DIAMETER "S" HOOK, OR CWD ENGINEER APPROVED EQUIVALENT, TO OPPOSITE END OF CHAIN. WELD SINGLE COIL OF CHAIN TO OPPOSITE SIDE ON GUARD RAILING FOR "S" HOOK TO HANG IN.
- ⑤ MOUNTING DETAIL METHOD IS OPTIONAL AND TO BE DETERMINED BY THE CWD ENGINEER: ANGLE MOUNT, SQUARE PLATE MOUNT, SLEEVE MOUNT, OR POST POCKET.
- ⑥ 1-1/2" NOMINAL STANDARD STEEL PIPE SHALL BE WELDED TO ANGLE MOUNT PIECE. ALL PIPE AND ANGLE TO BE CLEANED AND GALVANIZED AS SPECIFIED IN NOTE 1 ABOVE.
- ⑦ MOUNT PLATE TO CONCRETE WALK OR HEADWALL WITH FOUR (4) 3/8"Ø GALVANIZED REDHEADS (4 PLCS) OR CWD ENGINEER APPROVED EQUAL.
- ⑧ 1-1/2" NOMINAL STANDARD STEEL PIPE SHALL BE WELDED TO GUARDRAIL FOOTINGS. GUARDRAIL FOOTINGS SHALL BE 2" NOMINAL STANDARD STEEL PIPE WITH THREE #4 REBAR PIECES WELDED TO THE PIPE, AND EMBEDDED IN THE CONCRETE WHEN IT IS POURED. PLACE BOTTOM OF FOOTING IN CENTER OF WALKWAY SECTION. ALL PIPE SHALL BE CLEANED AND GALVANIZED AS SPECIFIED IN NOTE 1 ABOVE.
- ⑨ 1-1/2" NOMINAL STANDARD STEEL PIPE SHALL BE EMBEDDED A MINIMUM OF 9" INTO A 4" DIAMETER POST POCKET. A ANNULUS SHALL BE PACKED WITH NON-SHRINKABLE EPOXY GROUT.

③

| DIMENSION |     |
|-----------|-----|
| 'A'       | 'B' |
|           |     |
|           |     |
|           |     |



**NOTES**

1. STEEL COMPONENTS SHALL BE STAINLESS STEEL, HOT DIPPED GALVANIZED, OR EPOXY COATED.
2. DRILL 5/8" DIA. x 2" DEEP HOLE IN "CURED" CONCRETE (MIN. 3-7 DAYS) AND INSTALL DROP-IN ANCHOR WITH 1/2" DIA. ALL THREAD BOLD (STAINLESS STEEL).
3. LADDERS SHALL BE PLACED ON BOTH SIDES OF THE CANAL UPSTREAM OF BRIDGES AND SIPHONS.

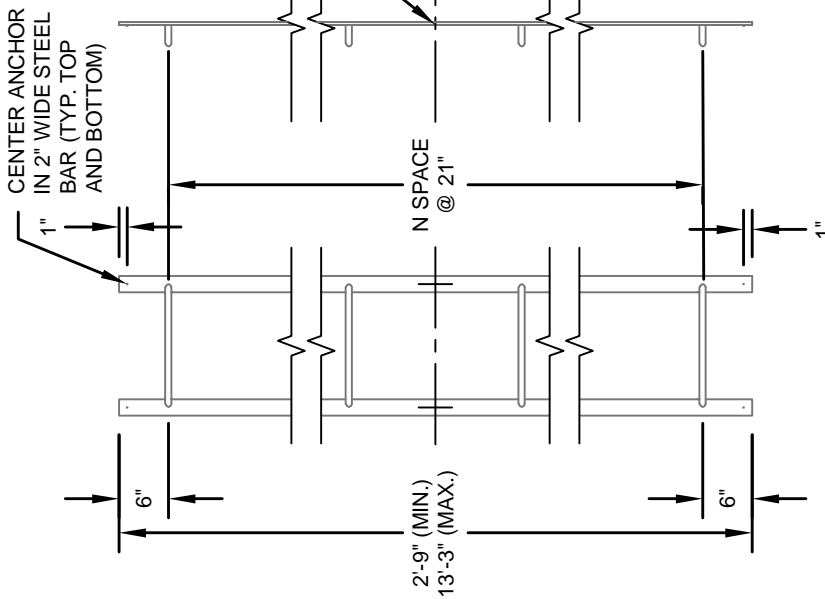

**LADDER SECTION**  
NTS

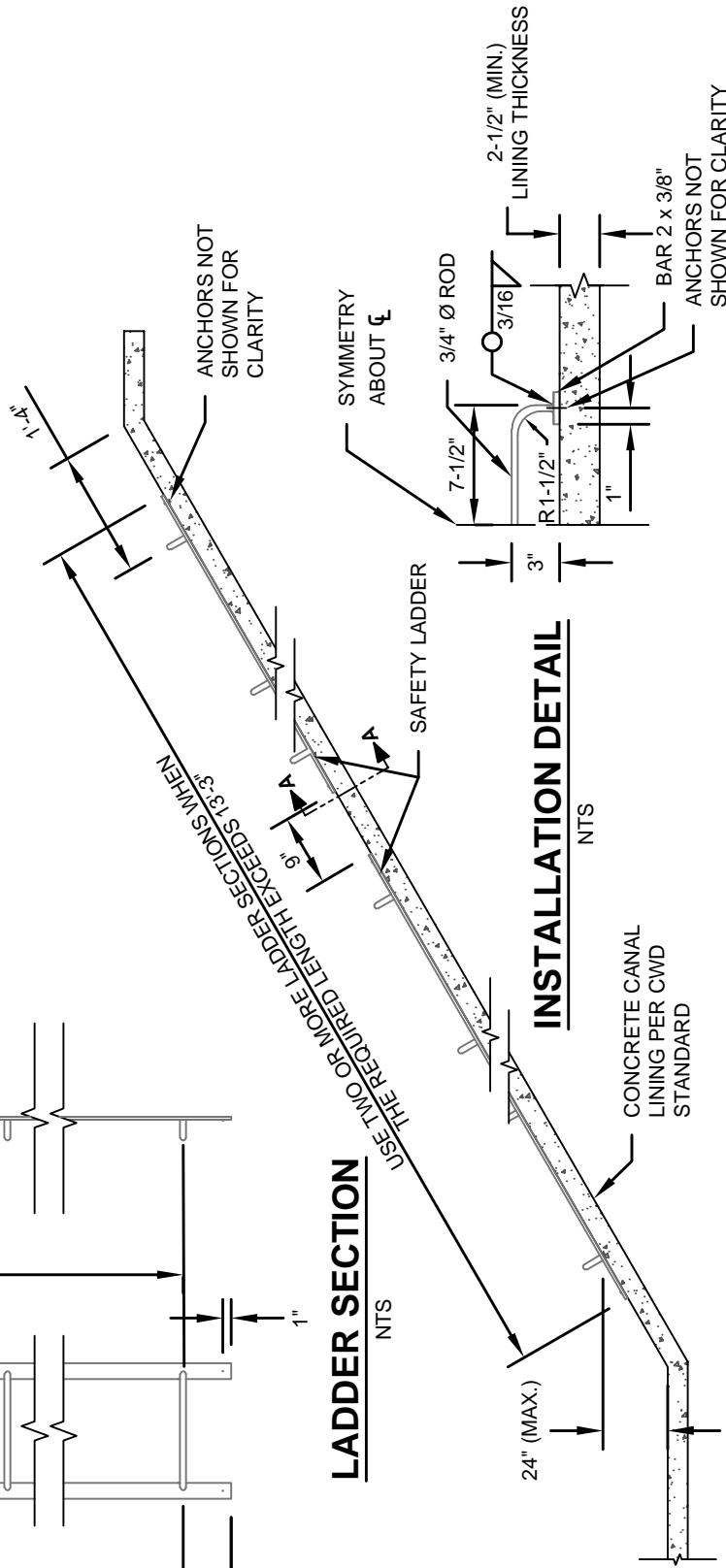

**INSTALLATION DETAIL**  
NTS

**SECTION A-A**  
NTS



**NOTES**

1. LADDER AND HARDWARE TO BE STAINLESS STEEL, HOT DIPPED, GALVANIZED, OR EPOXY COATED.
2. ANY CHANGES OR DEVIATIONS REQUIRED BY FIELD CONDITIONS SHALL BE APPROVED BY CWD INSPECTOR.

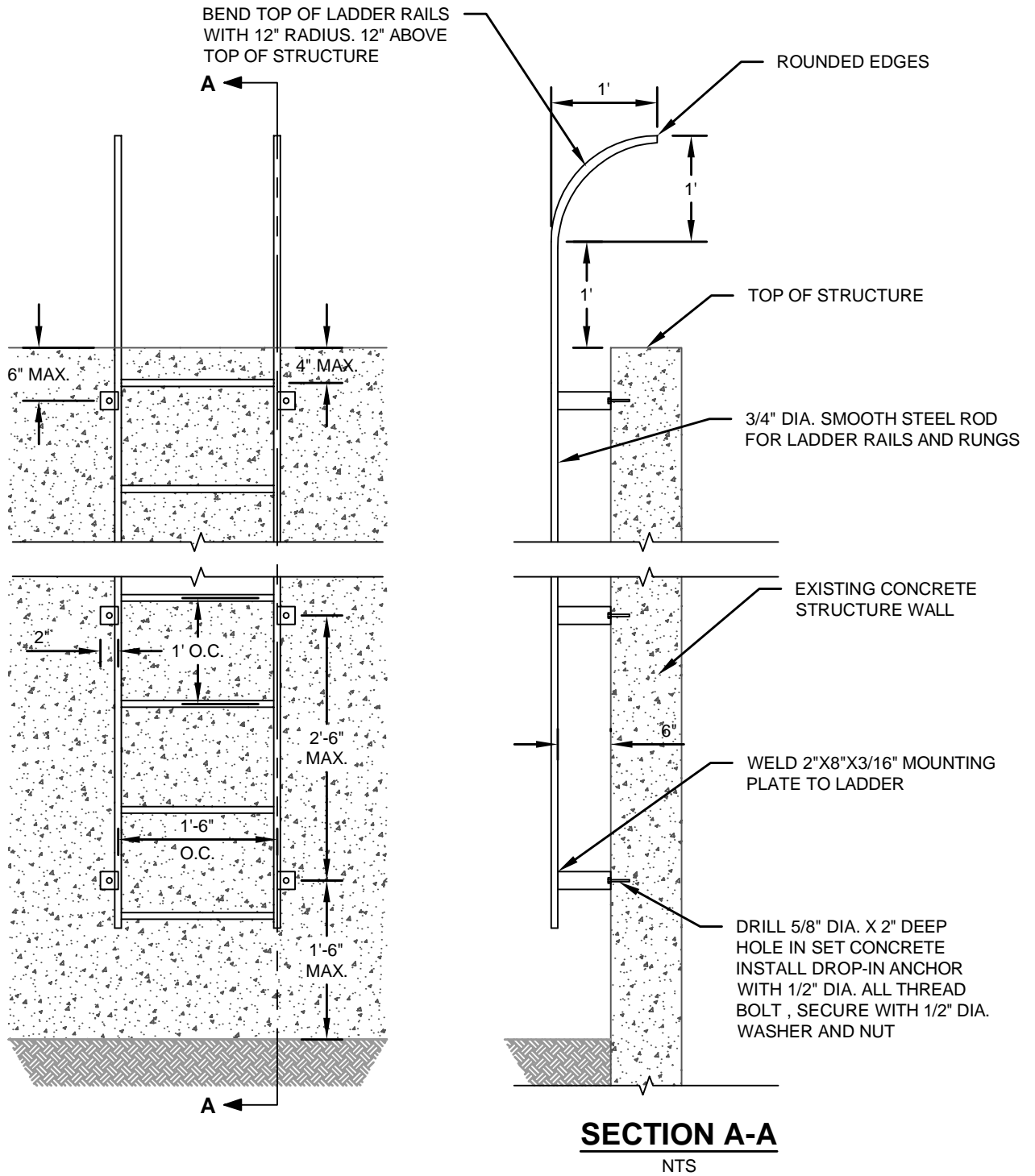

**CHOWCHILLA**  
WATER DISTRICT

**STEP LADDER FOR CONCRETE STRUCTURE**

SCALE: NOT TO SCALE

**F-5**

PREPARED BY: GJF, PAD

APPROVED BY: BT

DATE ADOPTED: 5-11-2022

SHEET 1 OF 1

**NOTE**

SEE SHEET 2 FOR CONSTRUCTION NOTES.

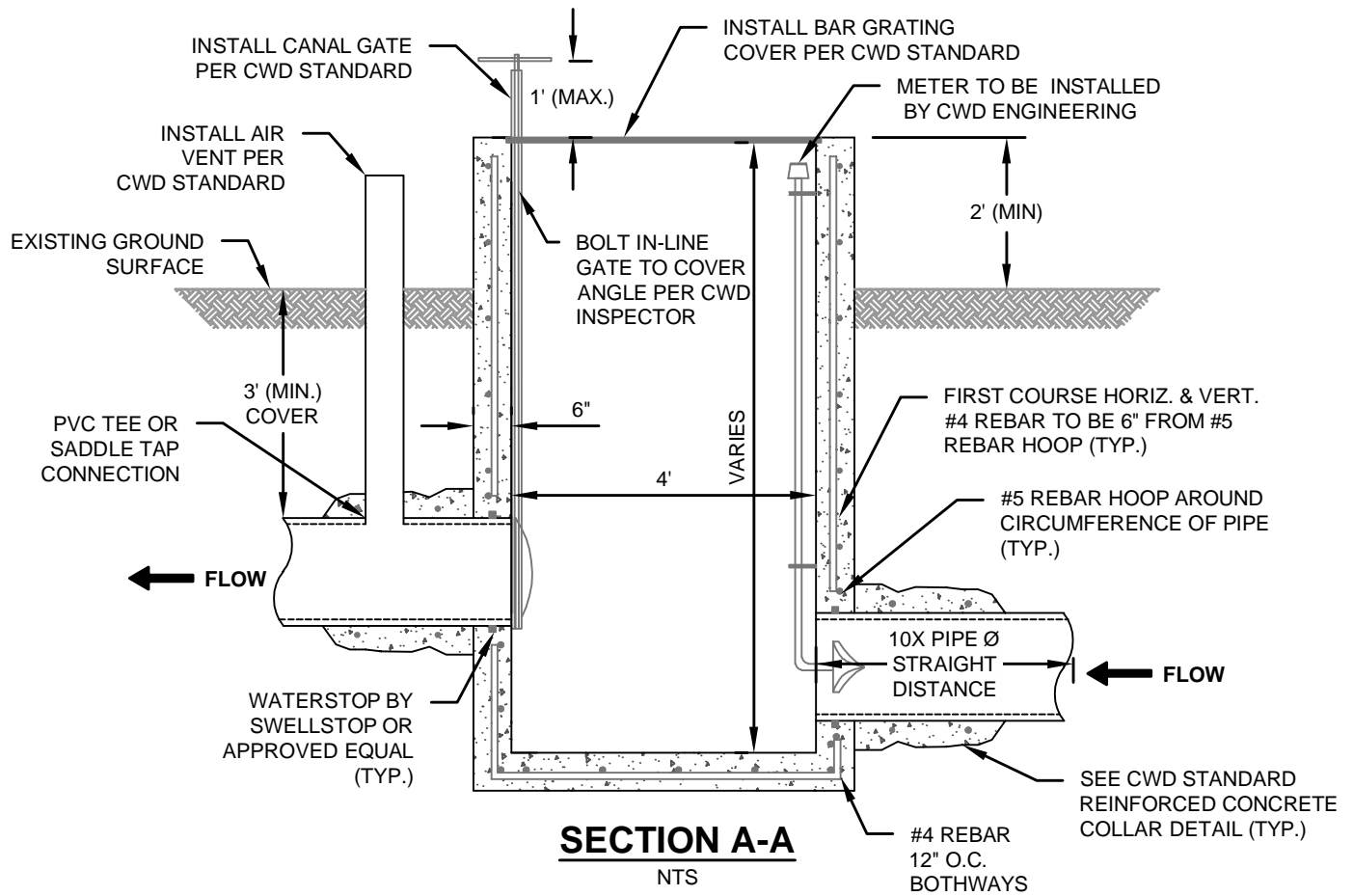
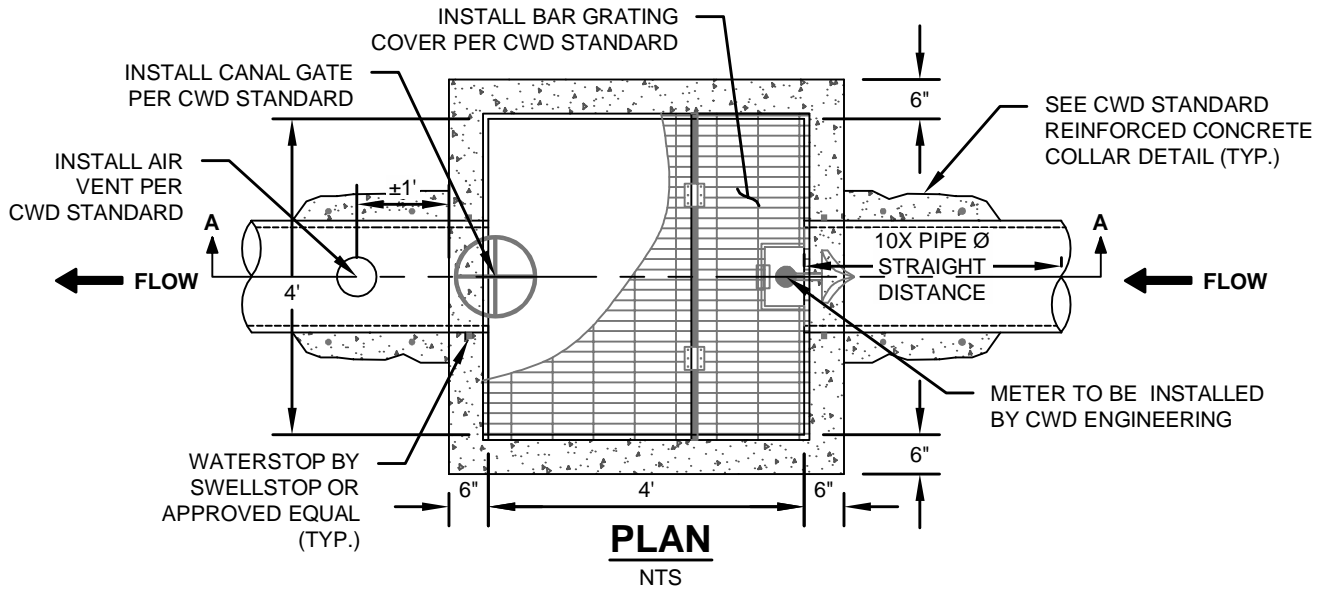

**CHOWCHILLA**  
WATER DISTRICT

**METER BOX DETAIL**

SCALE: NOT TO SCALE

**M-1**

PREPARED BY: GJF, PAD

APPROVED BY: BT

DATE ADOPTED: 5-11-2022

SHEET 1 OF 2

**CONSTRUCTION NOTES**

1. SENATE BILL SB x 7-7 REQUIRES THAT ALL WATER DELIVERY METERS ARE INSTALLED PER THE MANUFACTURER'S RECOMMENDATIONS. THE PIPELINE IMMEDIATELY UPSTREAM OF THE METER SHALL HAVE A CLEAR, UNOBSTRUCTED DISTANCE OF 10 TIMES THE PIPE DIAMETER. THE UPSTREAM DISTANCE CAN BE REDUCED TO 5 TIMES THE PIPE DIAMETER IF PIPELINE STRAIGHTENING VANES ARE INSTALLED UPSTREAM OF THE METER.
2. GATE & PIPELINE LAYOUT ARE FOR DETAIL PURPOSES ONLY. SEE CONSTRUCTION DRAWINGS FOR ACTUAL INSTALLATION.
3. DIMENSIONS, REBAR, & NOTES ARE FOR DETAIL PURPOSES ONLY. A SCALED DRAWING SHOULD BE PREPARED & SUBMITTED WITH ALL PLANS SETS TO PRIOR TO CONSTRUCTION.
4. IF REMOVAL OF AN EXISTING STRUCTURE OR PIPE IS SPECIFIED, REMOVAL SHALL BE BY SAWCUTTING, OR OTHER APPROVED METHOD, WITH THE CWD ENGINEER ON SITE DURING SAWCUTTING.
5. PREPARE SURFACE OF EXISTING PIPES BY WIRE BRUSHING, WATER BLASTING, OR SAND BLASTING AS REQUIRED BY THE CWD ENGINEER.
6. VIBRATE CONCRETE IN PLACE.
7. PROVIDE WATER TIGHT JOINTS.
8. CONCRETE SHALL BE 3000 PSI AT 28 DAYS OR BETTER.
9. CONCRETE PIPE SHALL BE CLEANED AND TREATED WITH AN APPROVED CONCRETE BONDING AGENT PRIOR TO CONCRETE PLACEMENT AS REQUIRED BY CWD ENGINEER.
10. PVC PIPE SHALL BE RUBBED AROUND THE OUTSIDE WITH PVC SOLVENT CEMENT AND SANDED TO ROUGHEN PRIOR TO CONCRETE PLACEMENT



**METER BOX DETAIL NOTES**

SCALE: NOT TO SCALE

**M-1**

PREPARED BY: GJF, PAD

APPROVED BY: BT

DATE ADOPTED: 5-11-2022

SHEET 2 OF 2

**NOTES**

METER OPTIONS:

1. SBx7-7 REQUIRES METERS TO BE INSTALLED PER THE MANUFACTURER'S SPECIFICATIONS.
2. PROPELLER METERS REQUIRE A STRAIGHT, UNOBSTRUCTED DISTANCE OF 10X PIPE DIAMETERS UPSTREAM, AND 2X PIPE DIAMETERS DOWNSTREAM, WITHOUT VALVES, GATES, OR ANGLE POINTS IN BETWEEN.
3. INLINE MAGNETIC METERS REQUIRE A STRAIGHT, UNOBSTRUCTED DISTANCE OF 2X PIPE DIAMETERS UPSTREAM, AND 1X PIPE DIAMETERS DOWNSTREAM, WITHOUT VALVES, GATES, OR ANGLE POINTS IN BETWEEN.

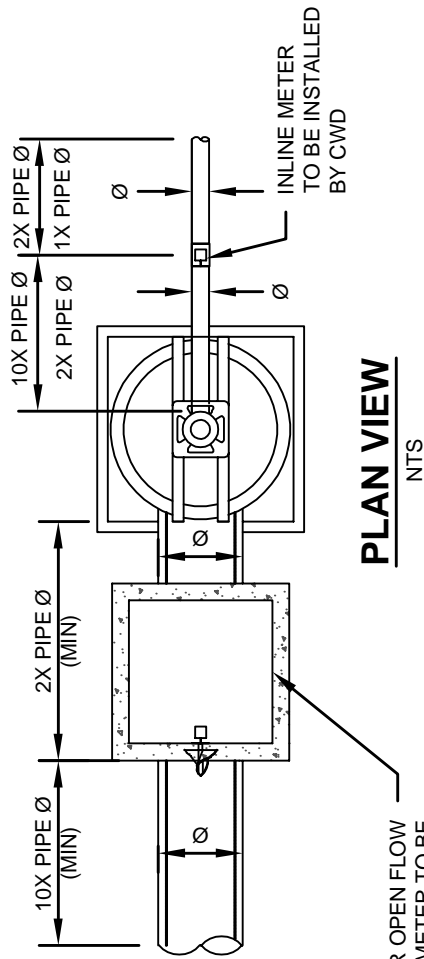

**PLAN VIEW**

NTS

METER BOX FOR OPEN FLOW  
 PROPELLER METER TO BE  
 CONSTRUCTED PER CWD STANDARD.  
 METER INSTALLED BY CWD

PUMP & STAND TO  
 BE LOCATED  
 OUTSIDE OF CWD'S  
 RIGHT-OF-WAY

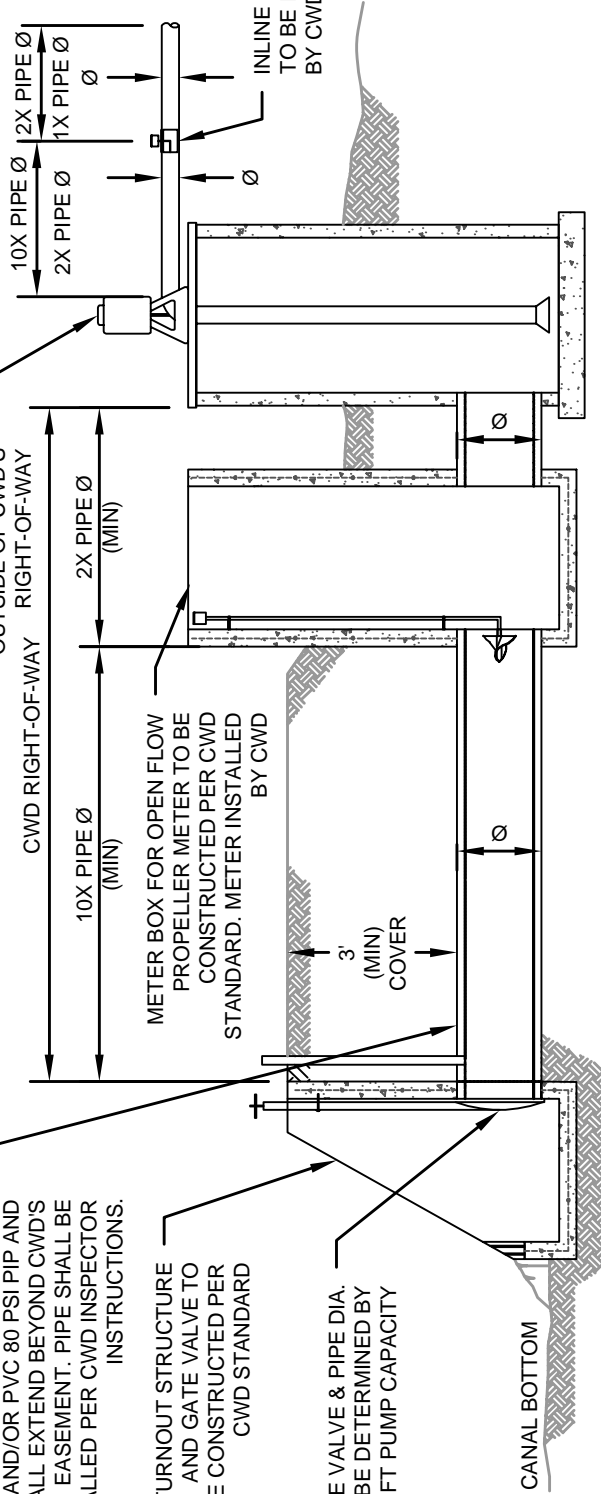

**ELEVATION VIEW**

NTS

ALL PIPE SHALL CONFORM TO  
 A.S.T.M. C-361 B-25 FOR CONCRETE  
 AND/OR PVC 80 PSI PIPE AND  
 SHALL EXTEND BEYOND CWD'S  
 EASEMENT. PIPE SHALL BE  
 INSTALLED PER CWD INSPECTOR  
 INSTRUCTIONS.

TURNOUT STRUCTURE  
 AND GATE VALVE TO  
 BE CONSTRUCTED PER  
 CWD STANDARD

GATE VALVE & PIPE DIA.  
 TO BE DETERMINED BY  
 LIFT PUMP CAPACITY

CANAL BOTTOM

# STRAIGHT PIPE RECOMMENDATIONS (X = PIPE DIAMETER)

**NOTE:** THESE CONFIGURATIONS ARE TO BE USED AS GENERAL GUIDELINES AND DO NOT COVER EVERY POSSIBLE INSTALLATION. IF THERE IS ANY CONCERN ABOUT THE LENGTH OF STRAIGHT PIPE REQUIRED FOR A SPECIFIC DEVICE, PLEASE CONTACT THE CWD ENGINEERING DEPARTMENT.

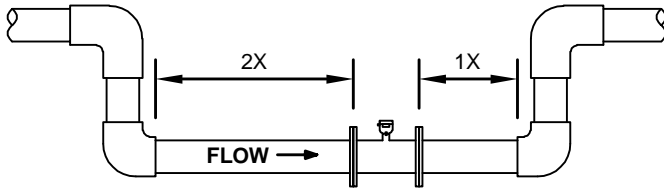

**TWO ELBOWS IN PLANE**

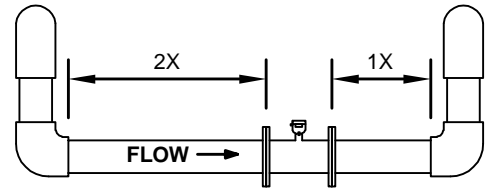

**TWO ELBOWS, OUT OF PLANE**

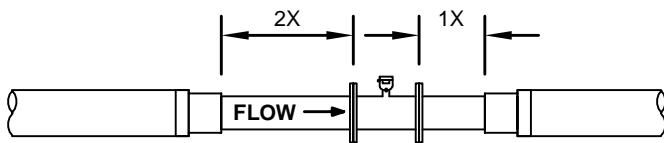

**REDUCED PIPE**

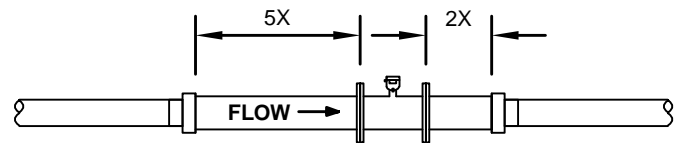

**EXPANDED PIPE**

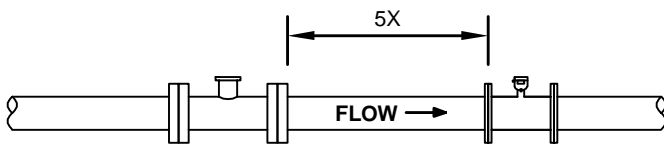

**PROPELLER METER BEFORE METER**

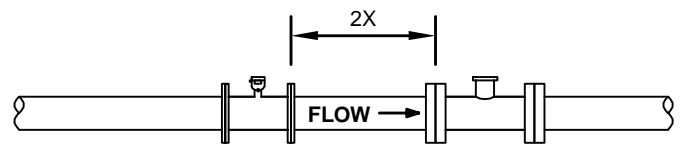

**PROPELLER METER AFTER METER**

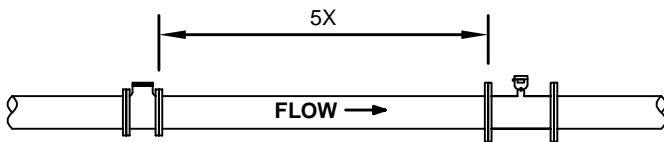

**CHECK VALVE BEFORE METER**

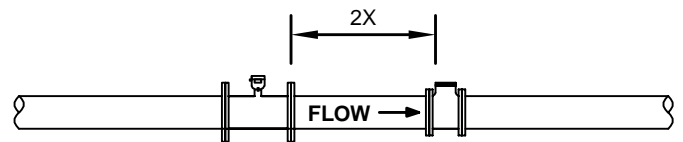

**CHECK VALVE AFTER METER**

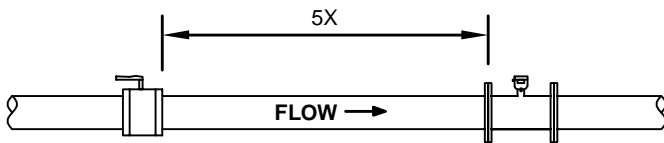

**BUTTERFLY VALVE BEFORE METER**

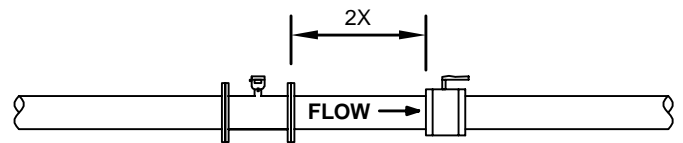

**BUTTERFLY VALVE AFTER METER**

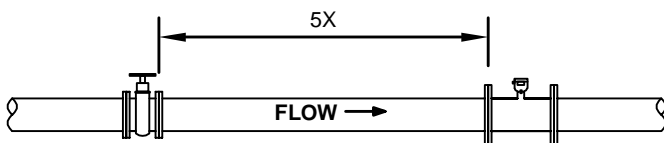

**GATE VALVE BEFORE METER**

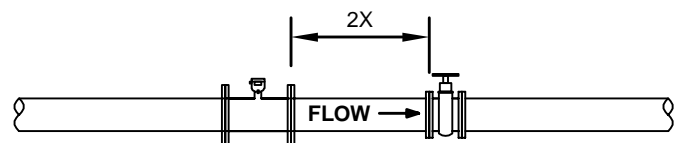

**GATE VALVE AFTER METER**

**CHOWCHILLA**  
WATER DISTRICT

**MAGNETIC METER STANDARD DETAIL**

SCALE: NOT TO SCALE

**M-3**

PREPARED BY: GJF, PAD

APPROVED BY: BT

DATE ADOPTED: 5-11-2022

SHEET 1 OF 2

# FULL PIPE RECOMMENDATIONS

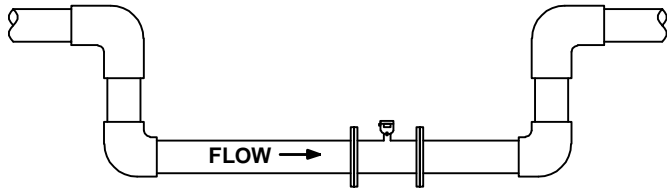

**RECOMMENDED:**  
KEEP PIPE FULL AT METER FOR ACCURACY

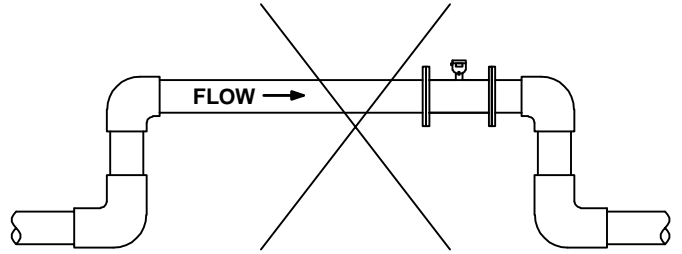

**NOT IDEAL:**  
ALLOWS AIR POCKETS TO FORM AT METER



**RECOMMENDED:**  
KEEP PIPE FULL AT METER FOR ACCURACY

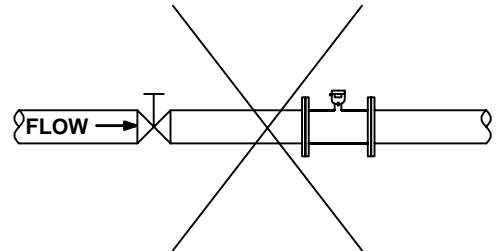

**NOT IDEAL:**  
POST-VALVE CAVITATION CAN CREATE AIR POCKET

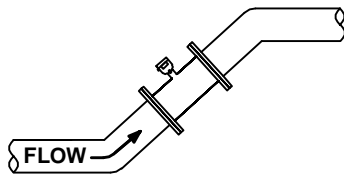

**RECOMMENDED:**  
ALLOWS AIR TO BLEED OFF

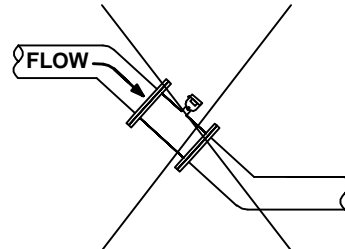

**NOT IDEAL:**  
AIR CAN BE TRAPPED

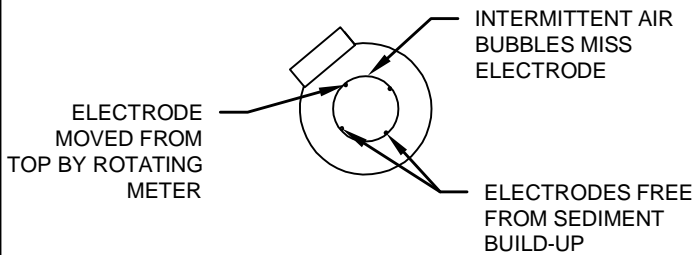

**RECOMMENDED:**  
IMPROVED ACCURACY RESULTS FROM UNIMPEDED ELECTRODES

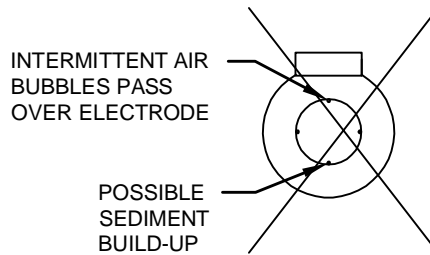

**NOT IDEAL:**  
AIR BUBBLES AND SEDIMENT ON THE ELECTRODES CAN AFFECT ACCURACY

**CHOWCHILLA**  
WATER DISTRICT

MAGNETIC METER STANDARD DETAIL 2

SCALE: NOT TO SCALE

M-3

PREPARED BY: GJF, PAD

APPROVED BY: BT

DATE ADOPTED: 5-11-2022

SHEET 2 OF 2

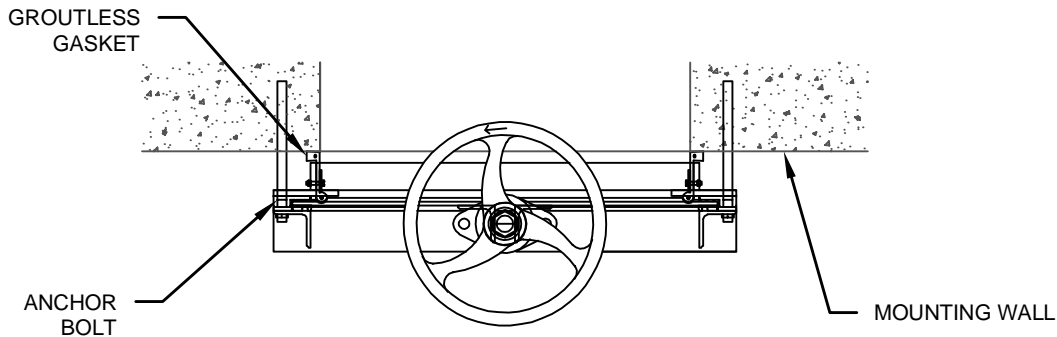

**PLAN**  
NTS

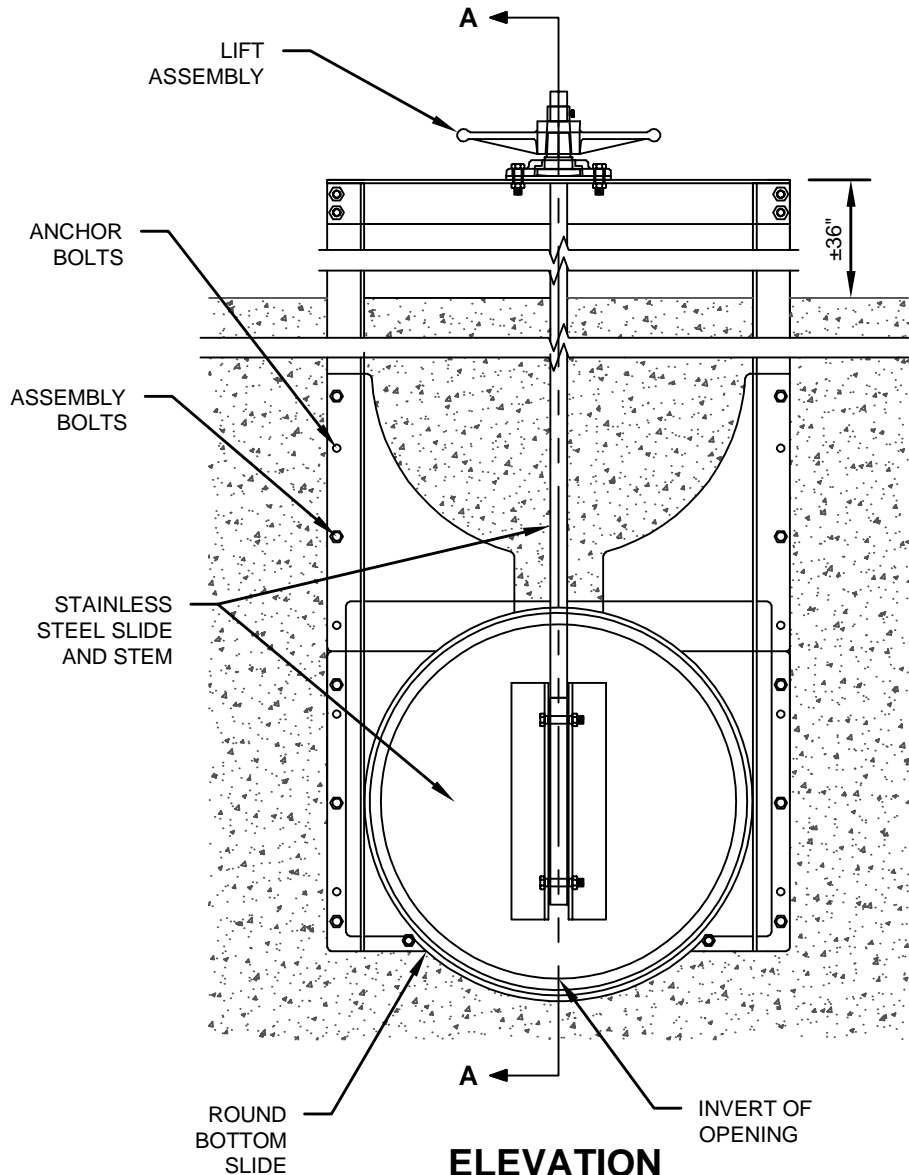

**ELEVATION**  
NTS

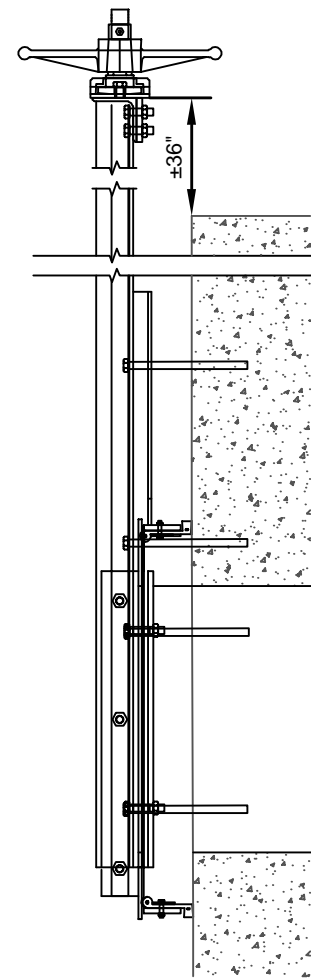

**SECTION A-A**  
NTS

**CHOWCHILLA**  
WATER DISTRICT

**CANAL SLIDE GATE**

SCALE: NOT TO SCALE

**0-1**

PREPARED BY: GJF, PAD

APPROVED BY: BT

DATE ADOPTED: 5-11-2022

SHEET 1 OF 2

**CANAL SLIDE GATE REQUIREMENTS**

- 1. GATES MUST HAVE RIGHT HAND THREADS.
- 2. GATES MUST BE CONSTRUCTED OF STAINLESS STEEL.
- 3. GATE WITH RISING STEM MUST HAVE A STOP NUT.
- 4. GATE RAILS SHALL BE STAINLESS STEEL.

**DELIVERY GATE TYPES**

- 1. FLAT BACK CANAL SLIDE GATE (FRESNO VALVES AND CASTING, INC. MODEL 101-C OR APPROVED EQUIVALENT).
- 2. FLAT BACK CANAL SLIDE GATE BACK PRESSURE BRACE (VALVES AND CASTINGS, INC. MODEL 20-10C OR APPROVED EQUIVALENT).
- 3. FLAT BACK PRESSURE GATE (NON-RISING STEM) WITH BACK PRESSURE BRACE (VALVES AND CASTINGS, INC. SERIES NO. 4200 OR APPROVED EQUIVALENT).



**CANAL SLIDE GATE NOTES**

SCALE: NOT TO SCALE

**O-1**

PREPARED BY: GJF, PAD

APPROVED BY: BT

DATE ADOPTED: 5-11-2022

SHEET 2 OF 2



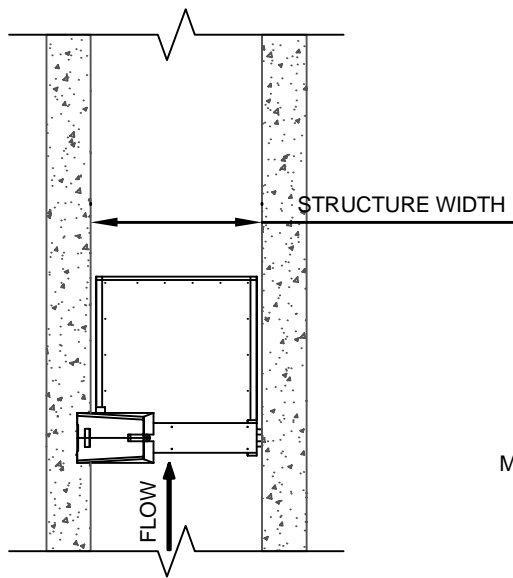

**PLAN VIEW (FULLY OPEN)**

NTS

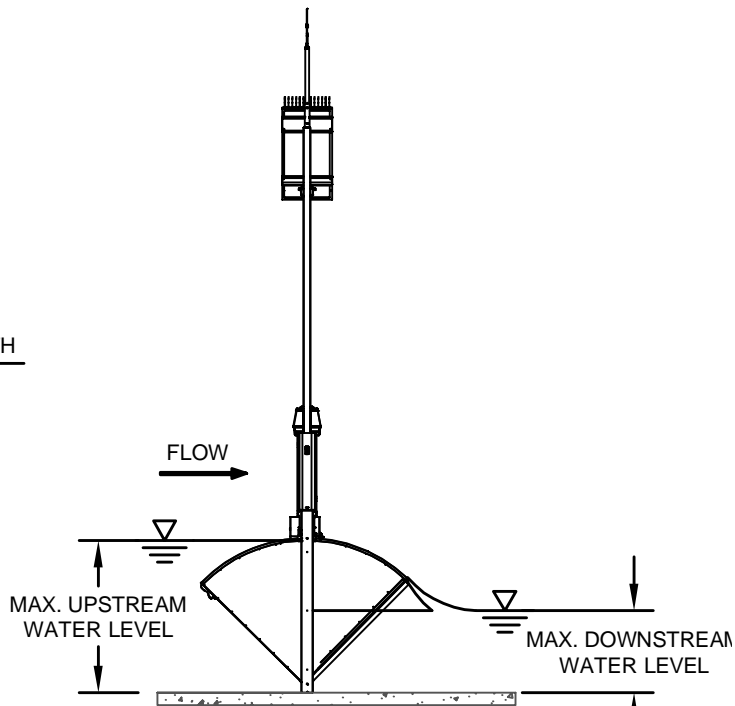

**ELEVATION (WATER LEVELS)**

NTS

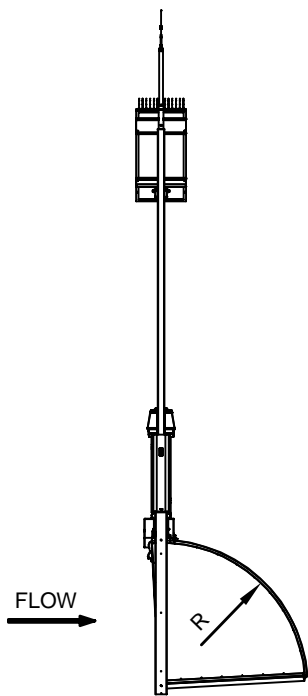

**ELEVATION (FULLY OPEN)**

NTS

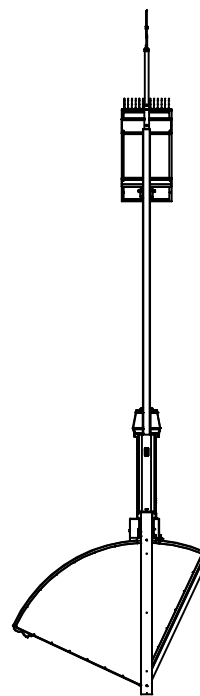

**ELEVATION (FULLY CLOSED)**

NTS

**CHOWCHILLA**  
WATER DISTRICT

FLUME GATE

SCALE: NOT TO SCALE

**0-2**

PREPARED BY: GJF, PAD

APPROVED BY: BT

DATE ADOPTED: 5-11-2022

SHEET 1 OF 2

**NOTES**

1. THE AUTOMATED OVERSHOT GATE SHALL BE INSTALLED IN KEY LOCATIONS THROUGHOUT THE DISTRICT WHERE CANAL/PIPELINE OBSTRUCTIONS COULD CAUSE POTENTIAL FLOODING AND SEVERE IMPACTS TO NEARBY PUBLIC FACILITIES.
2. AS FIELD CONDITIONS VARY WIDELY AND NO STANDARD WILL WORK IN ALL SITUATIONS, THIS STANDARD IS INTENDED TO PROVIDE GUIDANCE FOR THE PROJECT DESIGN ENGINEER.
3. THE AUTOMATED OVERSHOT GATE SHALL BE A FLUME GATE STEEL AS MANUFACTURED BY RUBICON WATER OR APPROVED EQUAL.
4. THE AUTOMATED OVERSHOT GATES SHALL CONTAIN THE FOLLOWING CHARACTERISTICS:
  - DATA INTERFACE: MODBUS SERIAL, DATA RADIO
  - DATA TAGS: 140+ AVAILABLE FOR INTEGRATION INTO SCADA SYSTEMS
  - CONTROL: LOCAL OR REMOTE VIA SCADA
  - MOTOR: 12V DC
  - ACCURACY: ± 2.5%
  - FRAME: EXTRUDED MARINE GRADE ALUMINUM
  - HARDWARE: STAINLESS-STEEL
  - WATER LEVEL SENSORS: ANODIZED ALUMINUM AND COPOLYMER ACETYL PLASTIC WITH STAINLESS-STEEL FITTINGS AND GOLD-PLATED CONNECTORS
  - POWER SUPPLY: 12V DC SELF CONTAINED BATTER CHARGED FROM SOLAR PANEL OR AC LINE POWER
  - PROTOCOLS: MODBUS , DNP3, MDLC
  - SCADA READY COMMUNICATION SYSTEM: CAN BE INTEGRATED TO MANY SCADA PLATFORMS
5. THE AUTOMATED OVERSHOT GATE SHALL BE OUTFITTED WITH AN ELECTRIC ACTUATOR, ROTORK IQ SERIES OR APPROVED EQUAL.
6. THE AUTOMATED OVERSHOT GATE SHALL BE DESIGNED FOR THE CHANNEL CAPACITY FLOW, HAVE ADJUSTABLE OPERATING PARAMETERS, OVERLOAD PROTECTION, PROGRAMMABLE SET POINTS, AND SCADA CONNECTIVITY TO DISTRICT SCADA SYSTEM.
7. THE AUTOMATED OVERSHOT GATE SHALL BE SOLAR DC OR LINE AC POWER.
8. LOCATION, SIZE AND TYPE OF WELD AS WELL AS TYPE OF WELDING ROD SHALL BE PER THE DESIGN ENGINEER'S APPROVED CALCULATIONS.
9. ALL ANCHOR BOLTS SHALL BE STAINLESS STEEL. BOLT THREADS TO BE CUT FLUSH WITH THE TOP OF THE NUT.
10. INLET STRUCTURE TO BE CONSTRUCTED PRIOR TO GATE FABRICATION. ALL DIMENSIONS TO BE VERIFIED BY CONTRACTOR PRIOR TO FABRICATION IN PRESENCE OF CWD ENGINEER TO ENSURE PROPER FIT WITHIN CONCRETE STRUCTURE.

|                                                                                     |                 |                         |              |
|-------------------------------------------------------------------------------------|-----------------|-------------------------|--------------|
|  |                 | <b>FLUME GATE NOTES</b> |              |
|                                                                                     |                 | SCALE: NOT TO SCALE     | <b>O-2</b>   |
| PREPARED BY: GJF, PAD                                                               | APPROVED BY: BT | DATE ADOPTED: 5-11-2022 | SHEET 2 OF 2 |

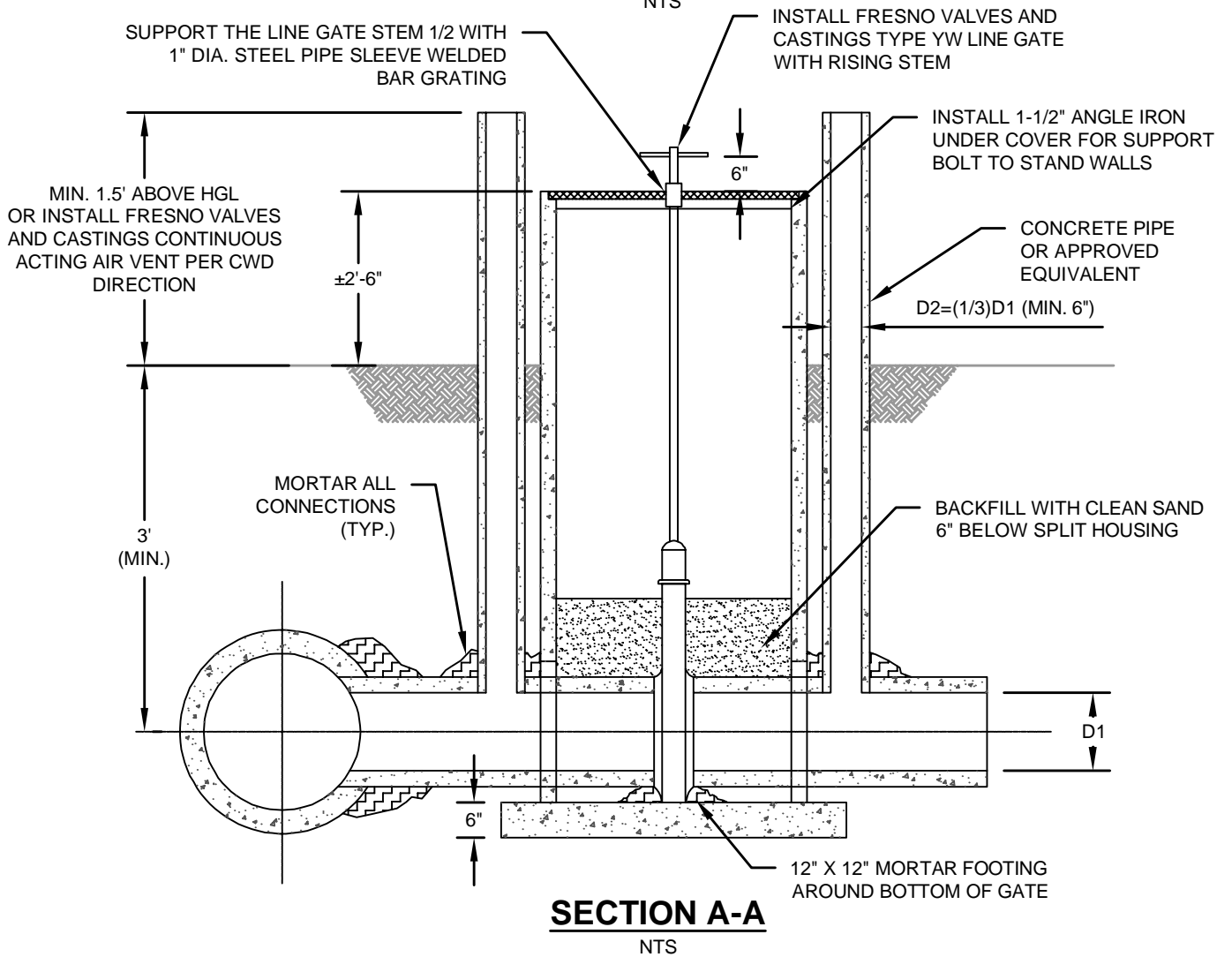
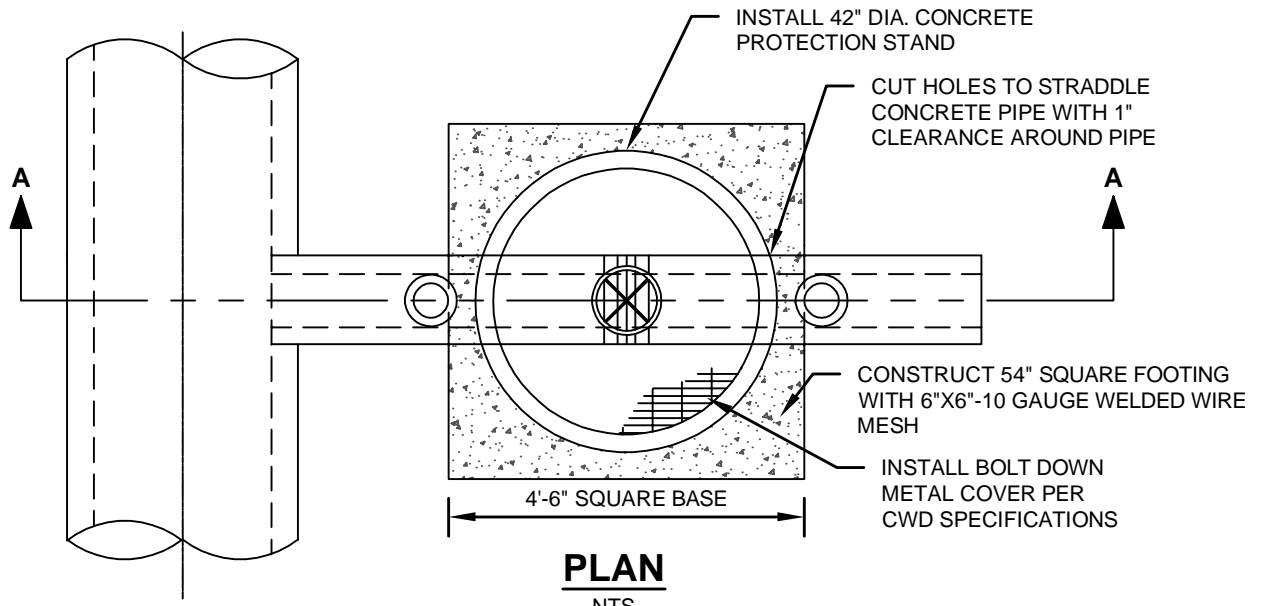

**CHOWCHILLA**  
WATER DISTRICT

**IN-LINE GATE WITH ACCESS STAND FOR  
CONCRETE PIPE**

SCALE: NOT TO SCALE

**O-3**

PREPARED BY: GJF, PAD

APPROVED BY: BT

DATE ADOPTED: 5-11-2022

SHEET 1 OF 1

12' WIDE DOUBLE SWING GATE

4' WIDE SWING GATE

15' (MIN.)

REFER TO CHAIN LINK FENCING DETAILS

3' (MIN.)

6' (MIN.)

3' (MIN.)

3' (MIN.)

HANDRAIL

**PLAN VIEW**

NTS

3' (MIN.)

3' (MIN.)

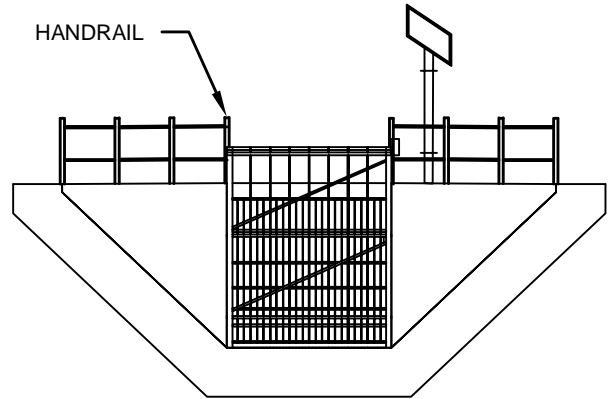

**ELEVATION FACING DOWNSTREAM**

NTS

HANDRAIL

FENCE

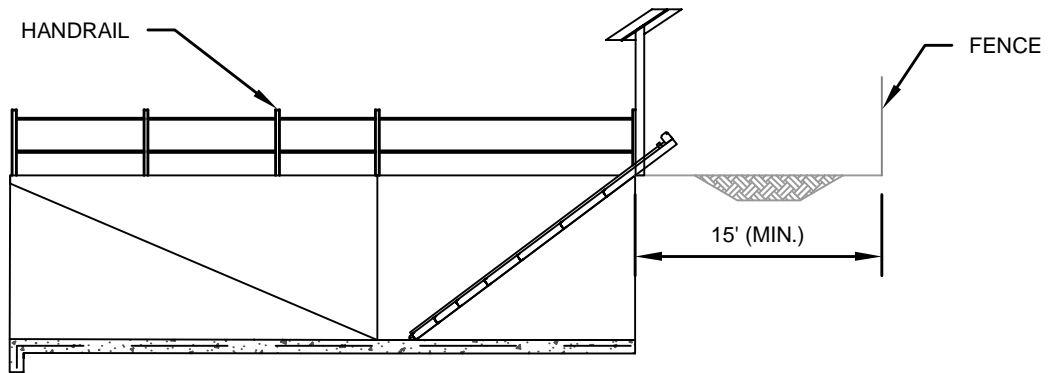

**SECTION A-A**

NTS

15' (MIN.)

**CHOWCHILLA**  
WATER DISTRICT

**AUTOMATED INLINE TRASH SCREEN  
DETAIL**

SCALE: NOT TO SCALE

**O-4**

PREPARED BY: GJF, PAD

APPROVED BY: BT

DATE ADOPTED: 5-11-2022

SHEET 1 OF 2

## **NOTES**

1. THE AUTOMATED INLINE TRASH SCREEN SHALL BE INSTALLED IN ALL NEW INLET STRUCTURES THROUGHOUT THE DISTRICT WHERE CANAL/PIPELINE OBSTRUCTIONS COULD CAUSE POTENTIAL FLOODING AND SEVERE IMPACTS TO NEARBY PUBLIC FACILITIES.
2. FIELD CONDITIONS VARY WIDELY AND NO STANDARD WILL WORK IN ALL SITUATIONS. THIS STANDARD IS INTENDED TO PROVIDE A GUIDANCE FOR THE PROJECT DESIGN ENGINEER.
3. THE AUTOMATED INLINE TRASH SCREEN SHALL BE A SELF-CLEANING SCREEN CLEANER AS MADE BY IWS (INTERNATIONAL WATER SCREENS), OR APPROVED EQUAL.
4. THE AUTOMATED INLINE TRASH SCREEN SHALL CONTAIN THE FOLLOWING FEATURES:
  - A. CONSTRUCTED WITH HEAVY DUTY STAINLESS STEEL 304, 316, AND 317 MATERIALS.
  - B. ALL WEAR SURFACES MUST BE COVERED WITH UHMW MATERIAL.
  - C. MUST CONTAIN INTERNAL HIGH PRESSURE SPRAY BAR.
  - D. BALDOR VARIABLE SPEED 1HP MOTOR SINGLE PHASE 115/230 VOLT, OR APPROVED EQUAL.
  - E. NORD MOBILGEAR GEARBOX 600XP 220 1HP 143TC WITH 352:1 RATIO, OR APPROVED EQUAL.
  - F. FLINT AND WALLING CENTRIFUGAL PUMP 3HP SELF PRIMING MODEL C22233 480 VOLT 3 PHASE, OR APPROVED EQUAL.
  - G. YARDNEY MODEL #SF-6 SCREEN WASH FILTER WITH 40-MESH SCREEN, OR APPROVED EQUAL.
  - H. MUST INCLUDE A CONVEYOR.
5. THE AUTOMATED INLINE TRASH SCREEN SHALL BE DESIGNED FOR THE CHANNEL CAPACITY FLOW, HAVE ADJUSTABLE OPERATING PARAMETERS, OVERLOAD PROTECTION, START WARNING SOUND, ADJUSTABLE TIMER, HAND/OFF/AUTO CONTROLS, DIFFERENTIAL LEVEL CONTROL, AND REMOTE MONITORING AND CONTROL COMPATIBLE WITH THE CWD SCADA SYSTEM.
6. THE AUTOMATED INLINE TRASH SCREEN SHALL BE SOLAR DC OR LINE AC POWER.
7. LOCATION, SIZE, AND TYPE OF WELD, AS WELL AS TYPE OF WELDING ROD, SHALL BE PER THE DESIGN ENGINEER'S APPROVED CALCULATIONS.
8. ALL ANCHOR BOLTS SHALL BE STAINLESS STEEL. BOLT THREADS TO BE CUT FLUSH WITH THE TOP OF THE NUT.
9. LOCATION AND NUMBER OF SUPPORT BARS SHALL BE PER THE DESIGN ENGINEER'S CALCULATIONS AND APPROVED BY THE CWD ENGINEER.
10. INLET STRUCTURE TO BE CONSTRUCTED PRIOR TO FABRICATION. ALL DIMENSIONS TO BE VERIFIED BY CONTRACTOR PRIOR TO FABRICATION IN PRESENCE OF CWD ENGINEER TO ENSURE PROPER FIT WITH THE CONCRETE STRUCTURE.
11. THE AUTOMATED INLINE TRASH SCREEN AND PITCH AND OPERATING SPEED SHALL BE PER MANUFACTURER'S RECOMMENDATIONS.

**CHOWCHILLA**  
WATER DISTRICT

**AUTOMATED INLINE TRASH SCREEN  
DETAIL NOTES**

SCALE: NOT TO SCALE

**O-4**

PREPARED BY: GJF, PAD

APPROVED BY: BT

DATE ADOPTED: 5-11-2022

SHEET 2 OF 2

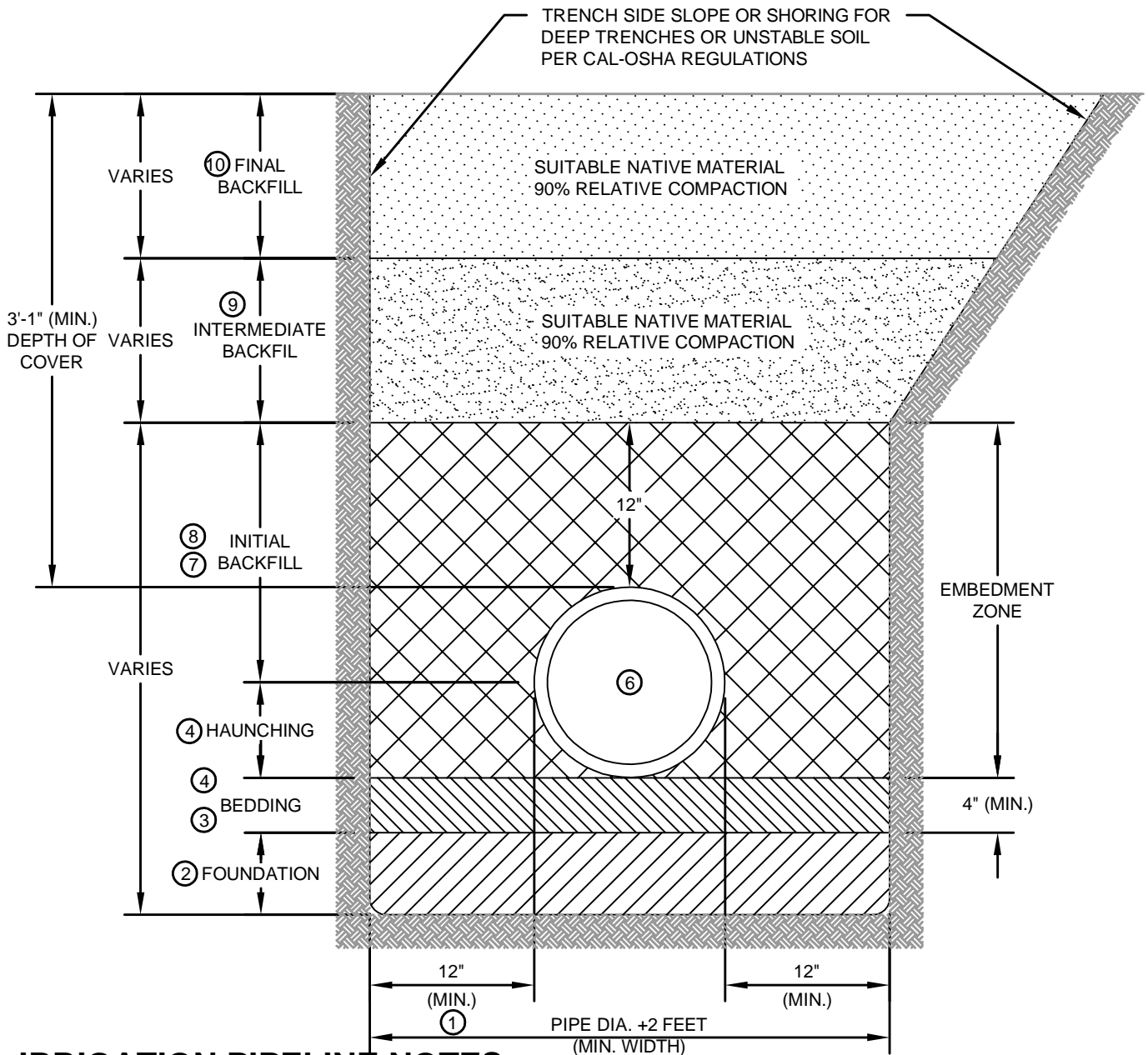

## IRRIGATION PIPELINE NOTES

1. SEE SHEET 2 FOR CONSTRUCTION NOTES.
2. PIPE SHALL BE RUBBER GASKETED REINFORCED CONCRETE PIPE (RGRCP) MANUFACTURED IN ACCORDANCE WITH ASTM C-361, OR AS APPROVED BY CWD ENGINEER.
3. RUBBER GASKETED JOINTS SHALL CONFORM THE REQUIREMENTS OF ASTM C-443.
4. BACKFILL OVER PIPE SHALL BE TO THE ORIGINAL GROUND SURFACE THE MINIMUM COVER SHALL BE 3 FEET AND THE MAXIMUM SHALL BE 5 FEET FOR CLASS A, 10 FEET FOR CLASS B, 15 FEET FOR CLASS C AND 20 FEET FOR CLASS D PIPE CLASS. DESIGNATIONS 25, 50, 75, 100, AND 126, DENOTE HYDROSTATIC PRESSURE HEADS IN FEET MEASURED TO CENTERLINE OF PIPE.
5. ADDITIONAL SURCHARGE LOADING OR VARIATION IN FIELD INSTALLATION FROM THESE DETAILS SHALL REQUIRE SEPARATE DESIGN SPECIFICATIONS FOR PIPE AND TRENCH BACKFILL.

**CHOWCHILLA**  
WATER DISTRICT

PIPELINE TRENCH BACKFILL DETAIL

SCALE: NOT TO SCALE

P-1

PREPARED BY: GJF, PAD

APPROVED BY: BT

DATE ADOPTED: 5-11-2022

SHEET 1 OF 2

**CONSTRUCTION NOTES**

- ① TRENCH WIDTHS SHALL BE AS SHOWN UNLESS THE PIPELINE SIZE IS 4 INCHES OR SMALLER, WHERE THE TRENCH SHALL HAVE A 12 INCH MINIMUM WIDTH.
- ② OVEREXCAVATION\_ZONE: THE BOTTOM OF TRENCH SHALL BE A FIRM, UNIFORM-BEARING SOIL SURFACE. WHEN UNSUITABLE OR DISTURBED THE CONTRACTOR SHALL REMOVE, REPLACE, AND COMPACT MATERIAL AS DIRECTED BY THE CWD ENGINEER. DEWATERING DUE TO HIGH GROUNDWATER OR CANAL SEEPAGE MAY BE REQUIRED. DEWATERING METHODS SHALL BE APPROVED BY THE CWD ENGINEER PRIOR TO COMMENCEMENT OF DEWATERING. ALL STRUCTURE SUBGRADES TO BE INSPECTED BY THE CWD ENGINEER PRIOR TO BACKFILL. SUBGRADE SHALL MEET 90% MAXIMUM DENSITY (ASTM D-1557).
- ③ PIPE BEDDING\_ZONE: PIPE BEDDING SHALL BE UNCOMPACTED GRANULAR SOIL CONTAINING NO MORE THAN 5% MATERIAL PASSING THE NUMBER 200 SIEVE, AND SHALL HAVE A MAXIMUM PARTICLE SIZE OF 3/4 INCH. BEDDING SHALL CONFORM TO THE SPECIFICATIONS BELOW. SOIL TYPES SHALL BE AS DETERMINED BY THE CWD ENGINEER.
  - A) ON SANDY SOIL (BEDDING):  
NATIVE MATERIAL, IF SUITABLE, OR SAND AS APPROVED BY THE CWD ENGINEER.
  - B) ON CLAY SOIL (BEDDING):  
4" MINIMUM SAND OR CWD APPROVED NATIVE MATERIAL ONLY.
- ④ A CLAY PLUG MAY BE REQUIRED UPSTREAM OF EACH MANHOLE, OR AT 660 FOOT INTERVALS. CLAY PLUG SHALL BE A MINIMUM OF 12 INCHES IN WIDTH AND EXTEND A MINIMUM OF 12 INCHES INTO UNDISTURBED TRENCH WALLS, TRENCH BOTTOM AND ABOVE THE TOP OF PIPE.
- ⑤ HAUNCH SUPPORT BACKFILL\_ZONE: HAUNCH SUPPORT BACKFILL SHALL BE COHESIVE SOIL OR GRANULAR MATERIAL CONTAINING MORE THAN 5% MATERIAL PASSING THE NUMBER 200 SIEVE, SHALL HAVE A MAXIMUM PARTICLE SIZE OF 3/4 INCH, PLACED IN LOOSE LIFTS NOT TO EXCEED 8" THICKNESS, OR 2-SACK CEMENT-SAND SLURRY. TRENCH WIDTH MAY BE REDUCED BY 6" ON EACH SIDE OF PIPE OF CEMENT-SAND SLURRY IS USED. COMPACTED EARTHFILL SHALL MEET 90% MAXIMUM DENSITY (ASTM D-1557) AND BE ACCOMPLISHED BY MANUALLY DIRECTED HAND COMPACTORS TO A MINIMUM DEPTH OF 12 INCHES OVER TOP OF PIPE. THE MAXIMUM LAYER THICKNESS SHALL BE 12 INCHES BEFORE COMPACTION.
- ⑥ PIPELINE SHALL BE INSTALLED ACCORDING TO MANUFACTURER'S INSTRUCTIONS AND SPECIFICATIONS. REFER TO IRRIGATION PIPELINE NOTE 4 FOR COVER REQUIREMENTS.
- ⑦ INITIAL BACKFILL\_ZONE: BACKFILL SHALL BE SOUND EARTHEN MATERIAL FREE OR ROCKS, HARDPAN, ORGANICS, AND DELETERIOUS MATERIAL, SHALL HAVE A MAXIMUM PARTICLE SIZE OF 3/4 INCH, PLACED IN LOOSE LIFTS NOT TO EXCEED 8" IN THICKNESS, AND HAND COMPACTED USING AIR TAMPERS OR PAD FOOT WHACKER TO 90% RELATIVE COMPACTION.
- ⑧ WATER PACKING OR JETTING SHALL ONLY BE USED ON SOILS APPROVED BY THE CWD ENGINEER. WHEN WATER PACKING OR JETTING IS USED, THE AMOUNT OF WATER SHALL BE CONTROLLED TO INSURE THAT POOLING OF EXCESS WATER DOES NOT OCCUR. THE WETTED FILL MUST BE ALLOWED TO REACH OPTIMUM MOISTURE AND THEN MECHANICALLY COMPACTED TO MEET 90% RELATIVE COMPACTION (ASTM D-1557) BEFORE ADDITIONAL BACKFILLING IS DONE. CARE MUST BE EXERCISED TO PREVENT PIPE FLOTATION DURING WATER PACKING OR JETTING, MEASURES MUST BE APPROVED BY THE CWD ENGINEER. THIS ITEM DOES NOT APPLY TO PLASTIC PIPELINES DUE TO PIPE FLOAT.
- ⑨ INTERMEDIATE BACKFILL\_ZONE: CWD REQUIRED COMPACTION TESTS SHALL BE AT THE LANDOWNER'S OR DEVELOPER'S EXPENSE. ANY RETESTS SHALL BE PAID BY THE CONTRACTOR. FREQUENCY AND LOCATION OF THE TESTS TO BE DETERMINED BY THE CWD ENGINEER.
- ⑩ FINAL BACKFILL\_ZONE: SHALL BE MINIMUM 90% RELATIVE COMPACTION (ASTM D-1557), UNLESS OTHER LOCAL AGENCY STANDARDS DICTATE HIGHER COMPACTION.

|                                                                                     |                 |                                          |              |
|-------------------------------------------------------------------------------------|-----------------|------------------------------------------|--------------|
|  |                 | PIPELINE TRENCH BACKFILL DETAIL<br>NOTES |              |
|                                                                                     |                 | SCALE: NOT TO SCALE                      | <b>P-1</b>   |
| PREPARED BY: GJF, PAD                                                               | APPROVED BY: BT | DATE ADOPTED: 5-11-2022                  | SHEET 2 OF 2 |

**CONSTRUCTION NOTES**

JOINT TO BE BANDED ON THE INSIDE PRIOR TO PLACING OF COLLAR (HAND HOLE IN EXISTING PIPE IS ALLOWED TO MAKE INSIDE BAND.) TWENTY-FOUR HOURS AFTER INSIDE BAND IS MADE. COAT WITH EPOXY OVER BANDED AREA, HAND HOLE PLUG TO BE EPOXIED AT MATCHING SURFACES WITH PIPE AND THEN MORTAR AND PLUG. EXTERNAL COLLAR WHEN IN PLACE AND SET MUST BE WATERED DOWN TO A POINT OF SATURATION THEN COVERED WITH WET BURLAP AND SHADED WITH SIX INCHES OF SOIL OVER ENTIRE AREA. SAID SOIL MUST BE KEPT MOIST FOR A PERIOD OF FIVE CONTINUOUS DAYS. THE ENTIRE SURFACE OF THE PIPE IN THE COLLAR AREA IS TO BE COATED WITH EPOXY JUST PRIOR TO POURING THE COLLAR.

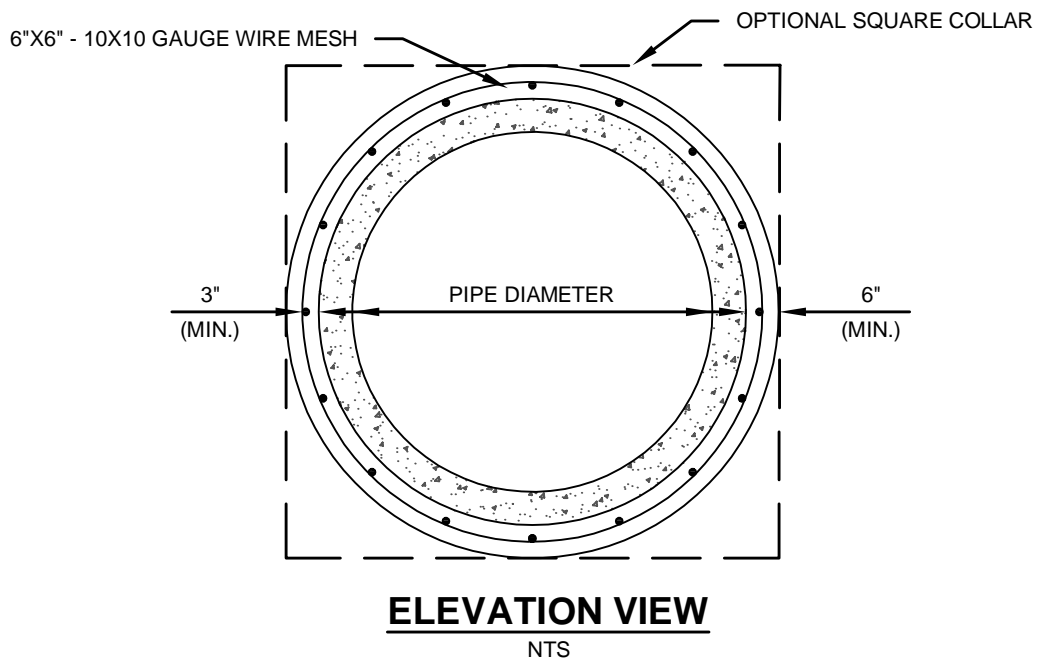
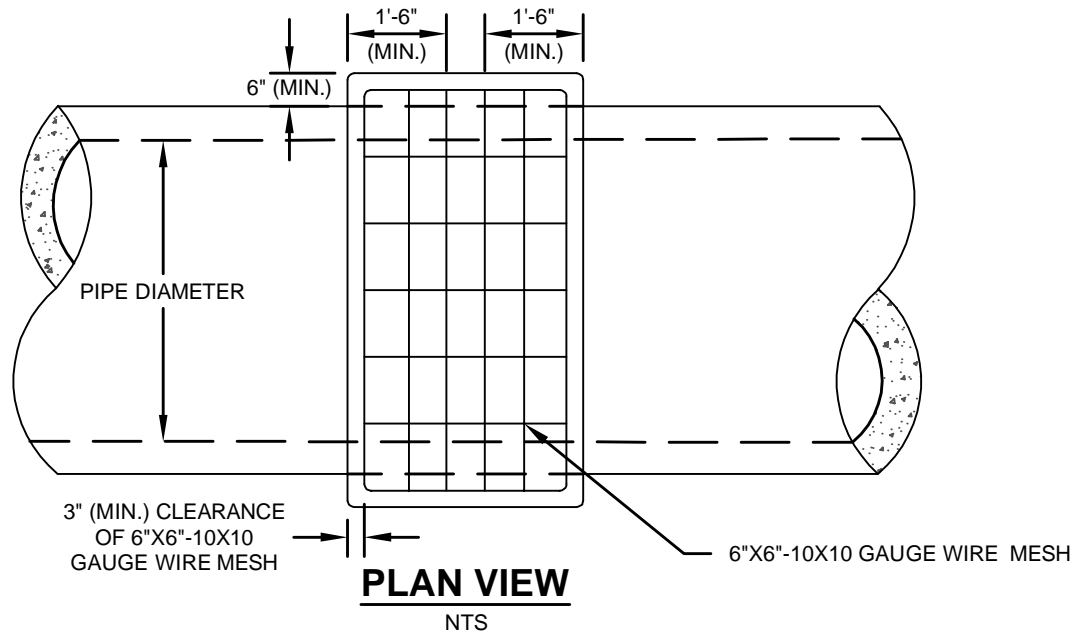

**CHOWCHILLA**  
WATER DISTRICT

**CONCRETE COLLAR DETAIL**

SCALE: NOT TO SCALE

**P-2**

PREPARED BY: GJF, PAD

APPROVED BY: BT

DATE ADOPTED: 5-11-2022

SHEET 1 OF 1



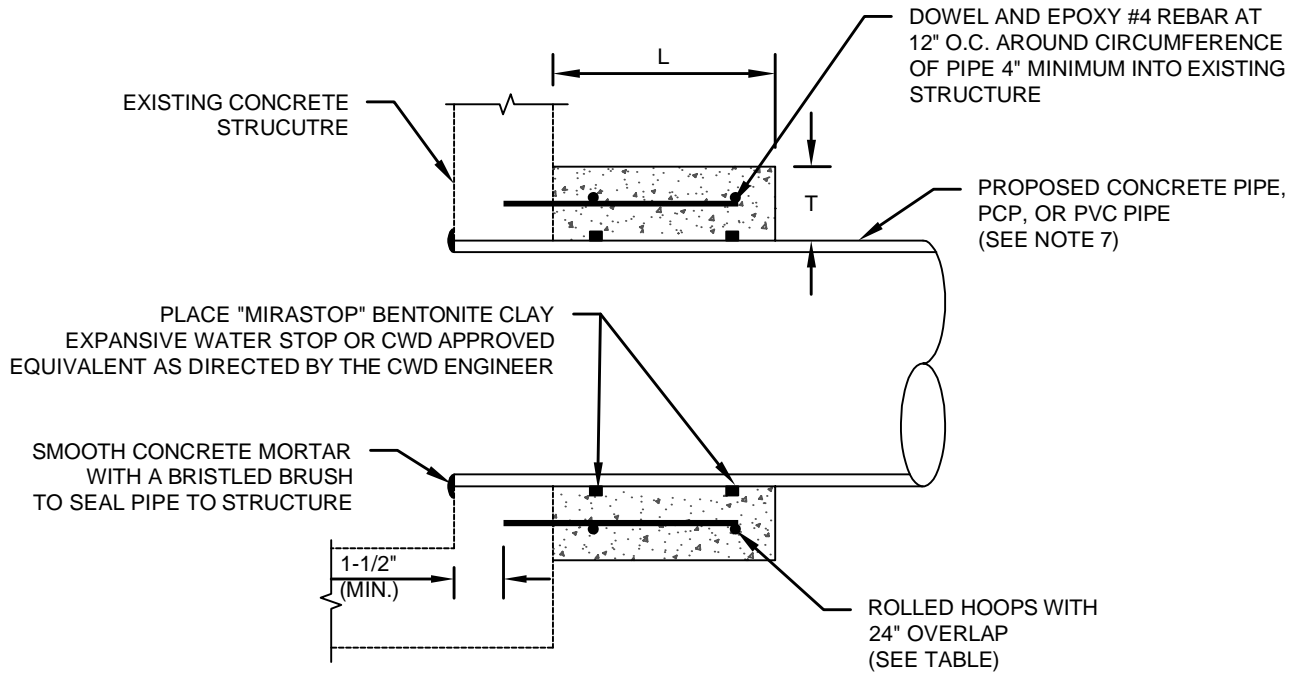

## PIPE TO EXISTING STRUCTURE DETAIL

### CONSTRUCTION NOTES

1. THIS STANDARD APPLIES TO CONCRETE PIPES, RCP OR PVC PIPES BEING CONNECTED TO AN EXISTING REINFORCED CONCRETE STRUCTURE WITH A CONCRETE COLLAR.
2. IF REMOVAL OF AN EXISTING STRUCTURE OR PIPE IS SPECIFIED, REMOVAL SHALL BE BY SAWCUTTING WITH THE CWD ENGINEER ON SITE DURING SAWCUTTING.
3. PREPARE SURFACE OF EXISTING STRUCTURES BY WIRE BRUSHING, WATER BLASTING, OR SAND BLASTING AS REQUIRED BY THE CWD ENGINEER.
4. VIBRATE CONCRETE IN PLACE.
5. PROVIDE WATER TIGHT JOINT.
6. CONCRETE SHALL BE 3000 PSI AT 28 DAYS OR BETTER AND CONFORM TO CWD STANDARDS.
7. CONCRETE PIPE: SHALL BE CLEANED AND TREATED WITH AN APPROVED CONCRETE BONDING AGENT PRIOR TO CONCRETE PLACEMENT AS REQUIRED BY CWD ENGINEER.

PVC PIPE: SHALL BE RUBBED AROUND THE OUTSIDE WITH PVC SOLVENT CEMENT AND SANDED TO ROUGHEN SURFACE PRIOR TO CONCRETE PLACEMENT.

| PIPE DIAMETER, D          | L         | T         | MIN. NO. HOOPS |
|---------------------------|-----------|-----------|----------------|
| LESS THAN OR EQUAL TO 24" | 18"       | 6"        | 2              |
| LESS THAN OR EQUAL TO 48" | 24"       | 8"        | 3              |
| LESS THAN OR EQUAL TO 72" | 30"       | 12"       | 4              |
| GREATER THAN 72"          | BY DESIGN | BY DESIGN | BY DESIGN      |

**CHOWCHILLA**  
WATER DISTRICT

**REINFORCED CONCRETE COLLAR DETAIL**

SCALE: NOT TO SCALE

**P-3**

PREPARED BY: GJF, PAD

APPROVED BY: BT

DATE ADOPTED: 5-11-2022

SHEET 1 OF 2

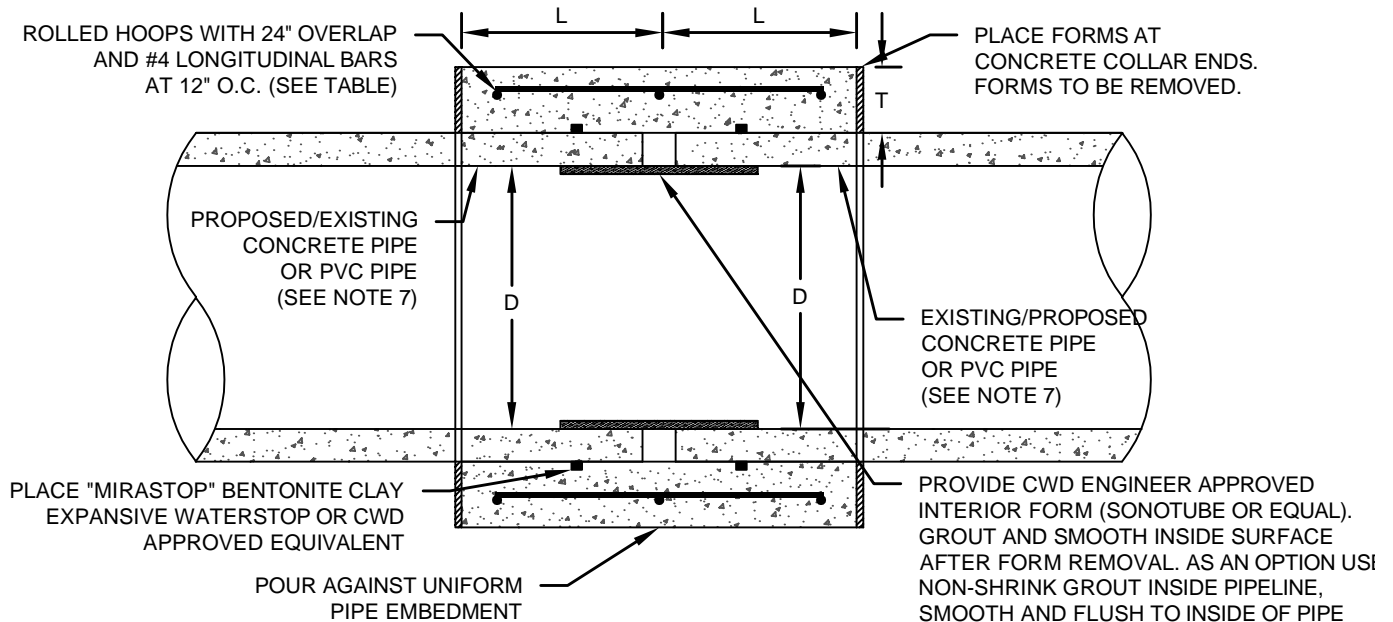

**PIPE TO EXISTING PIPE DETAIL**

**CONSTRUCTION NOTES:**

1. THIS STANDARD APPLIES TO CONCRETE PIPES (OR PVC PIPES IF SPECIFICALLY APPROVED) BEING CONNECTED WITH A CONCRETE COLLAR AND ONLY PIPES LEVEL OR AT THE SAME SLOPE. IT SHALL NOT APPLY TO PIPES WITH DEFLECTIONS AT THE CONNECTION POINT.
2. IF REMOVAL OF AN EXISTING STRUCTURE OR PIPE IS SPECIFIED, REMOVAL SHALL BE BY SAWCUTTING, OR OTHER APPROVED METHOD, WITH THE CWD ENGINEER ON SITE DURING SAWCUTTING.
3. PREPARE SURFACE OF EXISTING PIPES BY WIRE BRUSHING, WATER BLASTING, OR SAND BLASTING AS REQUIRED BY THE CWD ENGINEER.
4. VIBRATE CONCRETE IN PLACE.
5. PROVIDE WATER TIGHT JOINT.
6. CONCRETE SHALL BE 3000 PSI AT 28 DAYS OR BETTER AND CONFORM TO CWD STANDARD.
7. CONCRETE PIPE: SHALL BE CLEANED AND TREATED WITH AN APPROVED CONCRETE BONDING AGENT PRIOR TO CONCRETE PLACEMENT AS REQUIRED BY CWD ENGINEER.  
  
PVC PIPE: SHALL BE RUBBED AROUND THE OUTSIDE WITH PVC SOLVENT CEMENT AND SANDED TO ROUGHEN SURFACE PRIOR TO CONCRETE PLACEMENT.
8. FOR COLLAR WITH DIFFERENT PIPELINE DIAMETERS (D) THAT EXCEED 3 INCHES A MANHOLE OR OTHER APPROVED TRANSITION STRUCTURE IS REQUIRED.
9. A MANHOLE SHALL BE SUBSTITUTED FOR A COLLAR CONNECTION WHEN THE INTERSECTING PIPELINE ANGLE IS GREATER THAN OR EQUAL TO 22-1/2 DEGREES.

PLACE FORMS AT CONCRETE COLLAR ENDS. FORMS TO BE REMOVED.

EXISTING/PROPOSED CONCRETE PIPE OR PVC PIPE (SEE NOTE 7)

PROVIDE CWD ENGINEER APPROVED INTERIOR FORM (SONOTUBE OR EQUAL). GROUT AND SMOOTH INSIDE SURFACE AFTER FORM REMOVAL. AS AN OPTION USE NON-SHRINK GROUT INSIDE PIPELINE, SMOOTH AND FLUSH TO INSIDE OF PIPE PRIOR TO POURING COLLAR. JOINT TO BE BANDED ON THE INSIDE PRIOR TO PLACING OF COLLAR (HAND HOLE IN EXISTING PIPE ALLOWED TO MAKE INSIDE BAND.) TWENTY-FOUR HOURS AFTER INSIDE BAND IS MADE, COAT WITH EPOXY OVER BANDED AREA. HAND HOLE PLUG TO BE EPOXIED AT MATCHING SURFACES WITH PIPE AND THE MORTAR AND PLUG. EXTERNAL COLLAR WHEN IN PLACE AND SET MUST BE WATERED DOWN TO A POINT OF SATURATION THEN COVERED WITH WET BURLAP AND SHADED WITH SIX INCHES OF SOIL OVER ENTIRE AREA. SAID SOIL MUST BE KEPT MOIST FOR A PERIOD OF FIVE CONTINUOUS DAYS. THE ENTIRE SURFACE OF THE PIPE IN THE COLLAR AREA IS TO BE COATED WITH EPOXY JUST PRIOR TO POURING THE COLLAR.

| PIPE DIAMETER, D          | L         | T         | MIN. NO. HOOPS |
|---------------------------|-----------|-----------|----------------|
| LESS THAN OR EQUAL TO 24" | 18"       | 6"        | 3              |
| LESS THAN OR EQUAL TO 48" | 24"       | 8"        | 4              |
| LESS THAN OR EQUAL TO 72" | 30"       | 12"       | 5              |
| GREATER THAN 72"          | BY DESIGN | BY DESIGN | BY DESIGN      |

**BASIC ASSEMBLY INSTRUCTIONS**

1. CLEAN ALL DEBRIS FROM THE BELL END OF THE PIPE AND OR COUPLER CHECK THE GASKET POSITION. BE SURE IT IS COMPLETELY SEATED IN THE GROOVE WITH NO RAISED AREAS.
2. LUBRICATE THE SPIGOT END, USING ONLY THE MANUFACTURER'S RECOMMENDED LUBRICANT.
3. PLACE PIPE IN STRAIGHT ALIGNMENT. ASSEMBLE TO THE STOP LINE ON SPIGOT, COUPLER OR BELL.

**NOTES**

1. APPLICATION SHALL CONFORM TO MANUFACTURER'S SPECIFICATIONS AND OR CWD INSPECTOR INSTRUCTIONS.
2. INSTALL PIPE WITH PROPER BEDDING FOR UNIFORM LONGITUDINAL SUPPORT. WORK BACKFILL MATERIALS UNDER THE SIDES OF THE PIPE TO PROVIDE SATISFACTORY HAUNCHING. PLACE THE INITIAL BACKFILL TO A MINIMUM DEPTH OF 6" ABOVE PIPE.
3. USE ONLY MANUFACTURER'S RECOMMENDED LUBRICANT OR SOLVENTS, OTHER LUBRICANTS OR SOLVENTS MIGHT EFFECT THE PIPE OR GASKET MATERIAL.

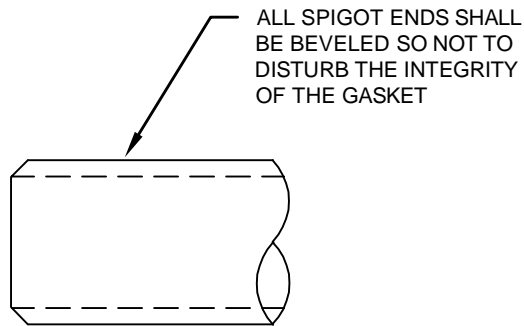

**DETAIL "A"**

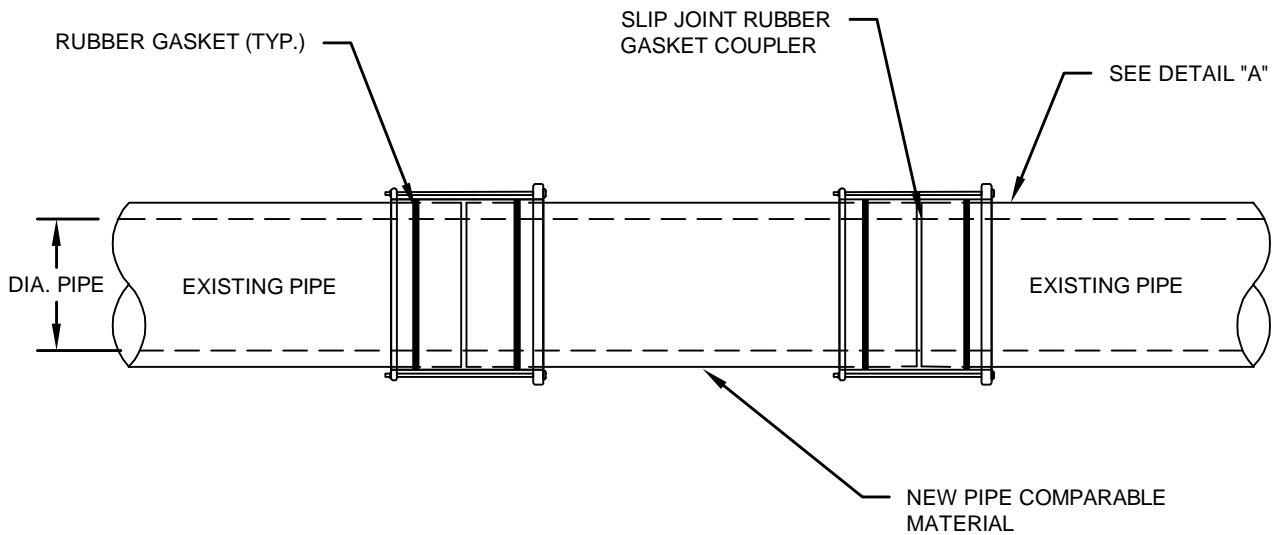

**CHOWCHILLA**  
WATER DISTRICT

**PVC REPAIR DETAIL**

SCALE: NOT TO SCALE

**P-4**

PREPARED BY: GJF, PAD

APPROVED BY: BT

DATE ADOPTED: 5-11-2022

SHEET 1 OF 1

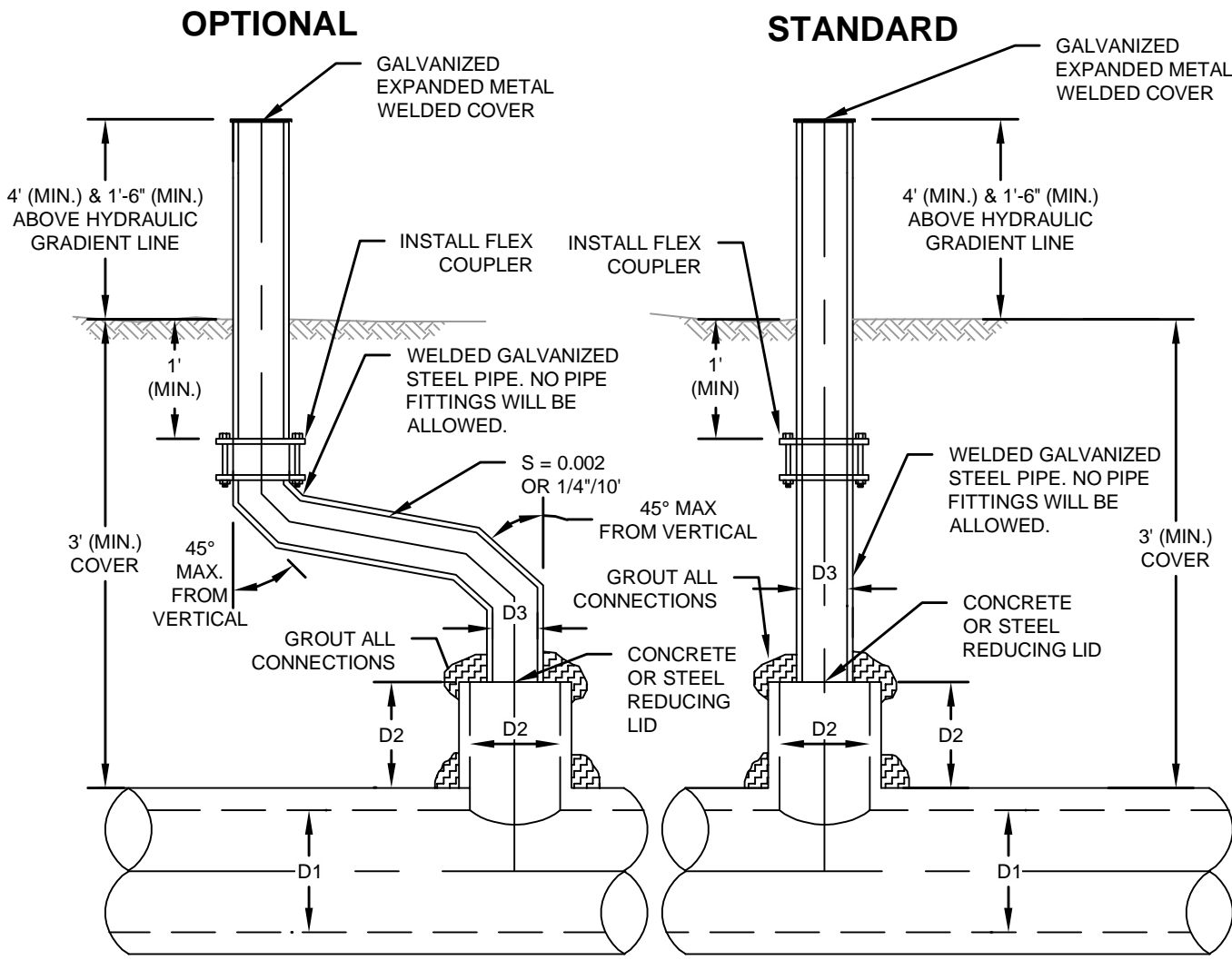

**VENT CONSTRUCTION REQUIREMENTS**

- VENTS SHOULD BE INSTALLED AT APPROXIMATE 700 FOOT INTERVALS, AT PIPELINE GRADE CHANGES, AT HIGH POINTS, AND IMMEDIATELY DOWNSTREAM OF ANY INLET STRUCTURES.

D1 = INSIDE PIPE DIAMETER

D2 = 1/3 D1 = HEIGHT & DIAMETER OF STARTER VENT

D3 = SEE BELOW SPECIFICATIONS

RUBBER GASKET REINFORCED CONCRETE PIPE (R.G.R.C.P.):

FOR PIPE DIA. <= 36" USE 4" DIA. GALVANIZED VENT WITH STARTER VENT.

FOR 36" < PIPE DIA. <= 48" USE 6" DIA. GALVANIZED VENT WITH STARTER VENT.

FOR PIPE DIA. > 48" USE 12" DIA. CONCRETE VENT WITH STARTER VENT.

POLYVINYL CHLORIDE (P.V.C.) PIPE:

FOR PIPE DIA. <= 24" USE 4" DIA. P.V.C. VENT PER DETAIL ON SHEET 2.

**CHOWCHILLA**  
WATER DISTRICT

**AIR VENT DETAIL WITH OPTIONAL OFFSET**

SCALE: NOT TO SCALE

**P-5**

PREPARED BY: GJF, PAD

APPROVED BY: BT

DATE ADOPTED: 5-11-2022

SHEET 1 OF 2

**NOTE**

A PVC TEE SECTION MAY REPLACE THE SADDLE TEE.

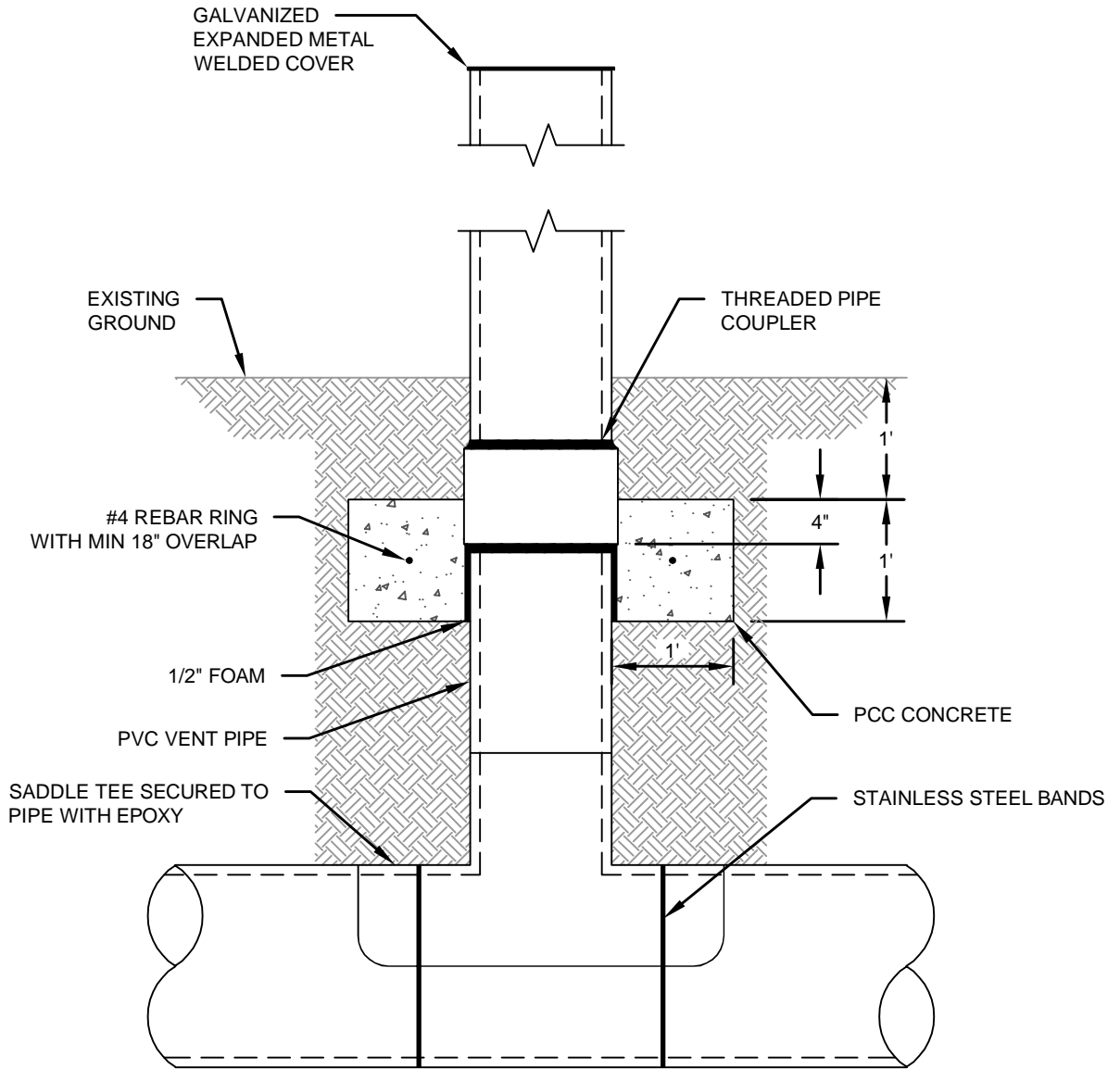

**PVC AIR VENT/STANDPIPE**

NTS

**CHOWCHILLA**  
WATER DISTRICT

AIR VENT DETAIL WITH OPTIONAL  
OFFSET2

SCALE: NOT TO SCALE

**P-5**

PREPARED BY: GJF, PAD

APPROVED BY: BT

DATE ADOPTED: 5-11-2022

SHEET 2 OF 2

GASKETED, WATERTIGHT, TRAFFIC RATED BOLTDOWN FRAME & COVER (SEE NOTE 1)

APPLY LAMP BLACK TO SURFACE

5' SQUARE

TOP OF 6" DIA. SCH. 40 STEEL PIPE. MUST BE 1.5' ABOVE HIGH WATER MARK AND MIN. 4'-0" ABOVE MAN HOLE RIM TO TOP OF PIPE. AS DIRECTED BY THE CWD ENGINEER. PAINT PIPE WITH PRIMER AND TWO FINISH COATS.

FINISH GRADE

2' (MIN.) GRADE RINGS SEE NOTE 2

1' (MAX.)

CONCENTRIC CONE

2'

4 #4 E.W.

90° WELDED ELBOW

WELDED REBAR

P.C.C. COLLAR (SEE SHEET 2)

4 #4 TOTAL

2 #4 E.W.

4 EA. #5 REBAR MIN. AT EACH CORNER. PLACE IN MANHOLE BASE WHEN CONCRETE IS WET.

AS REQUIRED

4'

6"

2 #5 OVER PIPE EACH END (SEE SHEET 2)

1' (MIN.)

6"

45°

VARIES

VARIES 12" TO 84" DIA.

1' (MIN.)

WALL THICKNESS (SEE TABLE)

SEE NOTE 6

| PIPE DIA. | MIN. WALL | MAX. WALL |
|-----------|-----------|-----------|
| 12"       | 27"       | 32"       |
| 15"       | 26"       | 30"       |
| 18"       | 24"       | 30"       |
| 21"       | 23"       | 27"       |
| 24"       | 21"       | 27"       |
| 27"       | 20"       | 24"       |
| 30"       | 18"       | 24"       |
| 33"       | 17"       | 21"       |
| 36"       | 15"       | 21"       |
| 42"       | 18"       | 18"       |
| 45"       | 18"       | 18"       |
| 48"       | 12"       | 15"       |
| 54"       | 12"       | 15"       |
| 60"       | 13"       | 18"       |
| 66"       | 13"       | 18"       |
| 72"       | 14"       | 18"       |
| 78"       | 14"       | 18"       |
| 84"       | 14"       | 18"       |

**CHOWCHILLA**  
WATER DISTRICT

**PRESSURE MANHOLE 12-84IN**

SCALE: NOT TO SCALE

**S-1**

PREPARED BY: GJF, PAD

APPROVED BY: BT

DATE ADOPTED: 5-11-2022

SHEET 1 OF 3

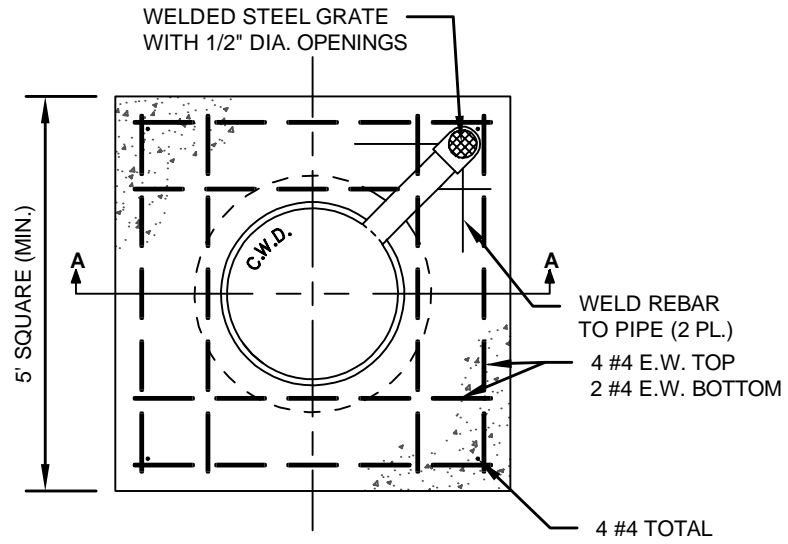

**PLAN VIEW**  
**MANHOLE COLLAR**

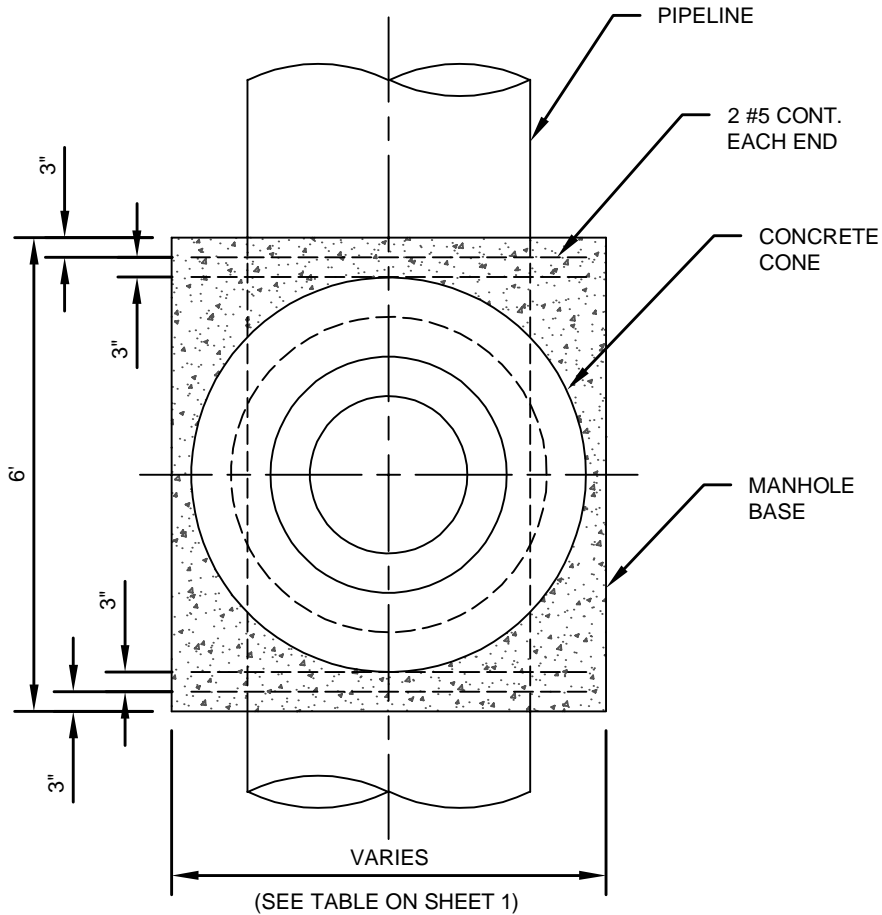

**PLAN VIEW**  
**MANHOLE BASE**

**CHOWCHILLA**  
WATER DISTRICT

**PRESSURE MANHOLE 12-84IN 2**

SCALE: NOT TO SCALE

**S-1**

PREPARED BY: GJF, PAD

APPROVED BY: BT

DATE ADOPTED: 5-11-2022

SHEET 2 OF 3

**CONSTRUCTION NOTES**

1. MANHOLE COVER & FRAME SHALL BE TRAFFIC RATED, GASKETED, WATERTIGHT, AND BOLTED DOWN. BOLTS SHALL BE 3/8" DIA, STANDARD HEX HEAD, STAINLESS STEEL, 6 IN QUANTITY. MAINTAIN 24-INCH CLEAR OPENING. COVER SHALL BE LETTERED "C.W.D." COVER AND FRAME SHALL BE ALHAMBRA FOUNDRY #A1254-B, CALIFORNIA CONCRETE PIPE A-624 BOLTDOWN WITHOUT VENT, OR CWD ENGINEER APPROVED EQUIVALENT.
2. TOTAL THICKNESS SHALL BE DETERMINED FOR EACH LOCATION. IN NO CASE SHALL IT BE LESS THAN 24".
3. ALL PRECAST MANHOLE MATERIAL SHALL CONFORM TO ASTM C-478.
4. ALL POURED IN PLACE P.C.C. SHALL BE CLASS "A," CONFORMING TO CALTRANS STANDARDS, SECTION 90, PLACED AGAINST UNDISTURBED SOIL OR SOIL COMPACTED TO 90% RELATIVE COMPACTION PER ASTM D-1557.
5. ALL JOINTS SHALL BE GROUTED WATER TIGHT INSIDE AND OUT WITH MORTAR CONFORMING TO CALTRANS STANDARDS, SECTION 65.
6. ON STRAIGHT PIPELINE RUNS, MANHOLE MAY BE INSTALLED OVER PIPE AND THE TOP OF PIPE REMOVED AT SPRING LINE TO FORM CHANNEL WALLS AT ANGLE POINTS, FORM P.C.C. CHANNEL TO MATCH PIPE PROFILE.
7. ALL STEEL REINFORCING SHALL BE 3" CLEAR FROM EARTH AND 2" CLEAR FROM FORMS UNLESS OTHERWISE SPECIFIED HEREIN.
8. MAXIMUM MANHOLE SPACING 660 FEET.
9. INSTALL VENT PIPE PER CWD STANDARD OR AS DIRECTED BY THE CWD ENGINEER.
10. WHEN THE PIPELINE IS PVC, RUB OUTSIDE OF PVC WITH SAND AND PVC GLUE JUST PRIOR TO CONCRETE POUR FOR MANHOLE BASE AT CONCRETE TO TO PVC INTERFACE ALSO ATTACH MIRAFI "MIRASTOP" BENTONITE CLAY WATERSTOP, OR CWD ENGINEER APPROVED EQUAL IN CONTINUOUS LOOP AROUND OUTSIDE OF PVC PIPE IN MANHOLE BASE WALL.
11. AIR VENT PIPE SHALL BE INSTALLED AS CLOSE TO GRADE RINGS AS POSSIBLE TO PREVENT AIR POCKETS.
12. AIR VENT PIPE SHALL BE OFFSET OUTSIDE OF MANHOLE COLLAR WHEN MANHOLE IS LOCATED IN TRAFFIC AREAS.
13. LOCATION OF STEEL PROTECTION POSTS AS DIRECTED BY CWD ENGINEER.
14. WHEN MANHOLE DEPTH TO FLOWLINE EXCEEDS 12', USE ECCENTRIC MANHOLE WITH STEP LADDER PER CWD STANDARD DETAIL.



**PRESSURE MANHOLE 12-84IN NOTES**

SCALE: NOT TO SCALE

**S-1**

PREPARED BY: GJF, PAD

APPROVED BY: BT

DATE ADOPTED: 5-11-2022

SHEET 3 OF 3



GASKETED, WATERTIGHT, TRAFFIC RATED BOLTDOWN FRAME & COVER (SEE NOTE 1)

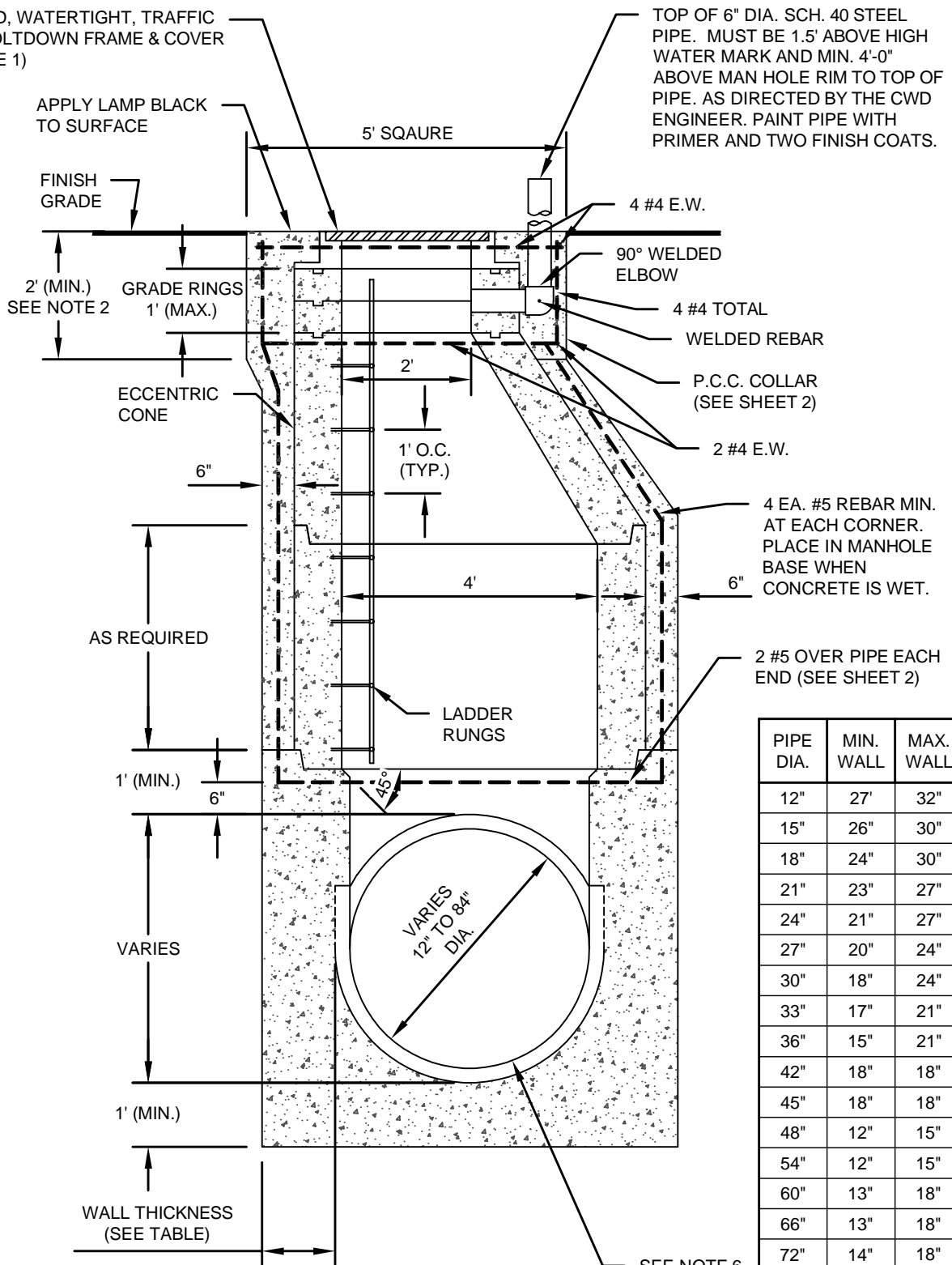

| PIPE DIA. | MIN. WALL | MAX. WALL |
|-----------|-----------|-----------|
| 12"       | 27"       | 32"       |
| 15"       | 26"       | 30"       |
| 18"       | 24"       | 30"       |
| 21"       | 23"       | 27"       |
| 24"       | 21"       | 27"       |
| 27"       | 20"       | 24"       |
| 30"       | 18"       | 24"       |
| 33"       | 17"       | 21"       |
| 36"       | 15"       | 21"       |
| 42"       | 18"       | 18"       |
| 45"       | 18"       | 18"       |
| 48"       | 12"       | 15"       |
| 54"       | 12"       | 15"       |
| 60"       | 13"       | 18"       |
| 66"       | 13"       | 18"       |
| 72"       | 14"       | 18"       |
| 78"       | 14"       | 18"       |
| 84"       | 14"       | 18"       |

**CHOWCHILLA**  
WATER DISTRICT

**PRESSURE ECCENTRIC MANHOLE 12-84IN**

SCALE: NOT TO SCALE

**S-2**

PREPARED BY: GJF, PAD

APPROVED BY: BT

DATE ADOPTED: 5-11-2022

SHEET 1 OF 3

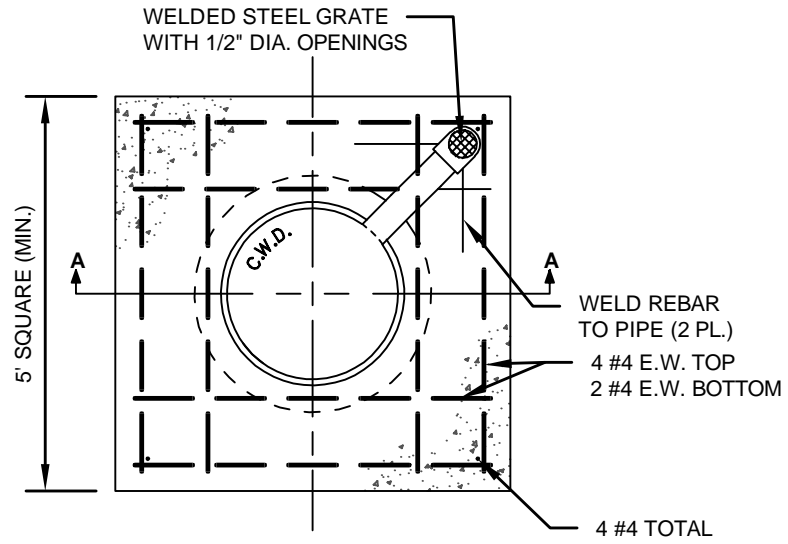

**PLAN VIEW**  
**MANHOLE COLLAR**

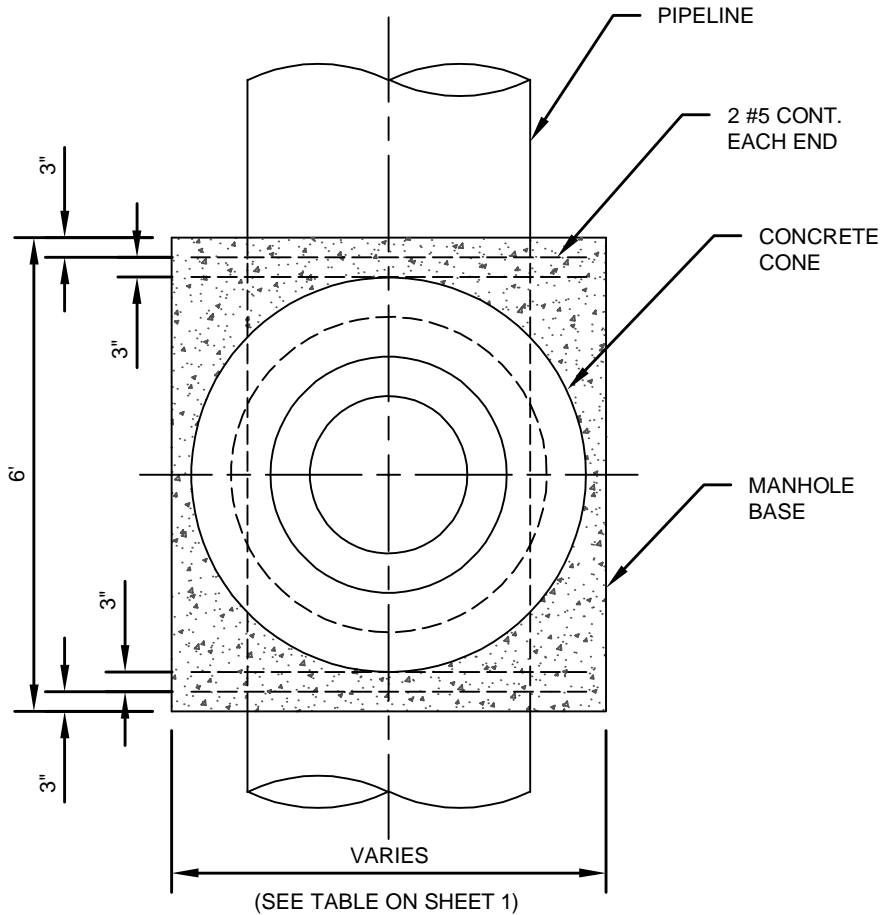

**PLAN VIEW**  
**MANHOLE BASE**

**CHOWCHILLA**  
WATER DISTRICT

**PRESSURE ECCENTRIC MANHOLE 12-84IN**  
**2**

SCALE: NOT TO SCALE

**S-2**

PREPARED BY: GJF, PAD

APPROVED BY: BT

DATE ADOPTED: 5-11-2022

SHEET 2 OF 3

## **CONSTRUCTION NOTES**

1. MANHOLE COVER & FRAME SHALL BE TRAFFIC RATED, GASKETED, WATERTIGHT, AND BOLTED DOWN. BOLTS SHALL BE 3/8" DIA, STANDARD HEX HEAD, STAINLESS STEEL, 6 IN QUANTITY. MAINTAIN 24-INCH CLEAR OPENING. COVER SHALL BE LETTERED "C.W.D." COVER AND FRAME SHALL BE ALHAMBRA FOUNDRY #A1254-B, CALIFORNIA CONCRETE PIPE A-624 BOLTDOWN WITHOUT VENT, OR CWD ENGINEER APPROVED EQUIVALENT.
2. TOTAL THICKNESS SHALL BE DETERMINED FOR EACH LOCATION. IN NO CASE SHALL IT BE LESS THAN 24".
3. ALL PRECAST MANHOLE MATERIAL SHALL CONFORM TO ASTM C-478.
4. ALL POURED IN PLACE P.C.C. SHALL BE CLASS "A," CONFORMING TO CALTRANS STANDARDS, SECTION 90, PLACED AGAINST UNDISTURBED SOIL OR SOIL COMPACTED TO 90% RELATIVE COMPACTION PER ASTM D-1557.
5. ALL JOINTS SHALL BE GROUTED WATER TIGHT INSIDE AND OUT WITH MORTAR CONFORMING TO CALTRANS STANDARDS, SECTION 65.
6. ON STRAIGHT PIPELINE RUNS, MANHOLE MAY BE INSTALLED OVER PIPE AND THE TOP OF PIPE REMOVED AT SPRING LINE TO FORM CHANNEL WALLS AT ANGLE POINTS, FORM P.C.C. CHANNEL TO MATCH PIPE PROFILE.
7. ALL STEEL REINFORCING SHALL BE 3" CLEAR FROM EARTH AND 2" CLEAR FROM FORMS UNLESS OTHERWISE SPECIFIED HEREIN.
8. MAXIMUM MANHOLE SPACING 660 FEET.
9. INSTALL VENT PIPE PER CWD STANDARD OR AS DIRECTED BY THE CWD ENGINEER.
10. WHEN THE PIPELINE IS PVC, RUB OUTSIDE OF PVC WITH SAND AND PVC GLUE JUST PRIOR TO CONCRETE POUR FOR MANHOLE BASE AT CONCRETE TO TO PVC INTERFACE ALSO ATTACH MIRAFI "MIRASTOP" BENTONITE CLAY WATERSTOP, OR CWD ENGINEER APPROVED EQUAL IN CONTINUOUS LOOP AROUND OUTSIDE OF PVC PIPE IN MANHOLE BASE WALL.
11. AIR VENT PIPE SHALL BE INSTALLED AS CLOSE TO GRADE RINGS AS POSSIBLE TO PREVENT AIR POCKETS.
12. AIR VENT PIPE SHALL BE OFFSET OUTSIDE OF MANHOLE COLLAR WHEN MANHOLE IS LOCATED IN TRAFFIC AREAS.
13. LOCATION OF STEEL PROTECTION POSTS AS DIRECTED BY CWD ENGINEER.
14. LADDER AND HARDWARE TO BE STAINLESS STEEL, HOT DIPPED, GALVANIZED, OR EPOXY COATED.
15. ANY CHANGES OR DEVIATIONS REQUIRED BY FIELD CONDITION SHALL BE APPROVED BY CWD INSPECTOR.

**CHOWCHILLA**  
WATER DISTRICT

**PRESSURE ECCENTRIC MANHOLE 12-84IN  
NOTES**

SCALE: NOT TO SCALE

**S-2**

PREPARED BY: GJF, PAD

APPROVED BY: BT

DATE ADOPTED: 5-11-2022

SHEET 3 OF 3

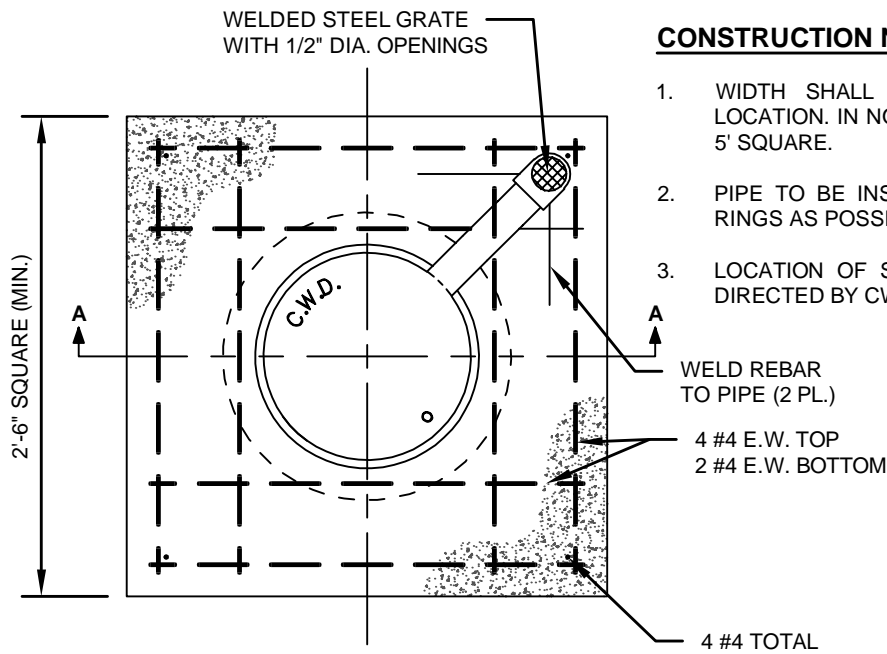

**PLAN VIEW  
MANHOLE COLLAR**

**CONSTRUCTION NOTES**

1. WIDTH SHALL BE DETERMINED FOR EACH LOCATION. IN NO CASE SHALL IT BE LESS THAN 5' SQUARE.
2. PIPE TO BE INSTALLED AS CLOSE TO GRADE RINGS AS POSSIBLE TO PREVENT AIR POCKETS.
3. LOCATION OF STEEL PROTECTION POSTS AS DIRECTED BY CWD ENGINEER.

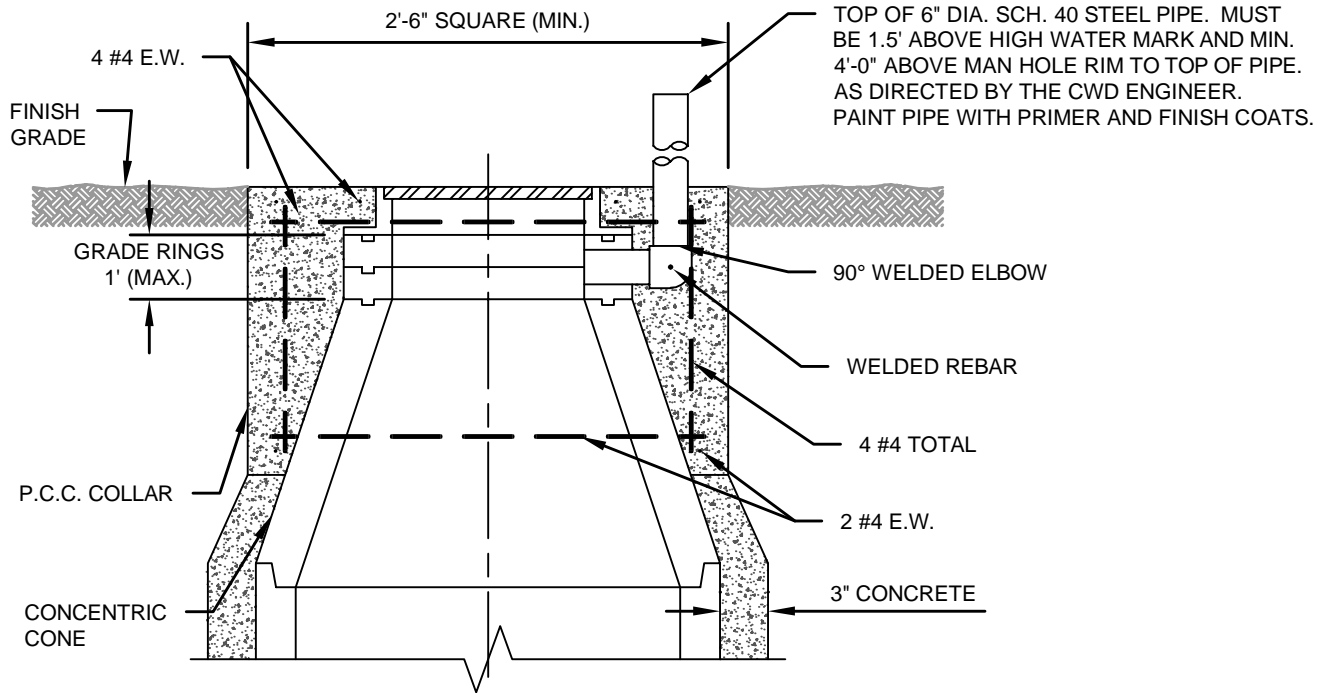

**SECTION A-A  
MANHOLE COLLAR UNIMPROVED AREA**

**CHOWCHILLA  
WATER DISTRICT**

**PRESSURE MANHOLE COLLAR DETAIL  
WITH PIPE VENT**

SCALE: NOT TO SCALE

**S-3**

PREPARED BY: GJF, PAD

APPROVED BY: BT

DATE ADOPTED: 5-11-2022

SHEET 1 OF 1

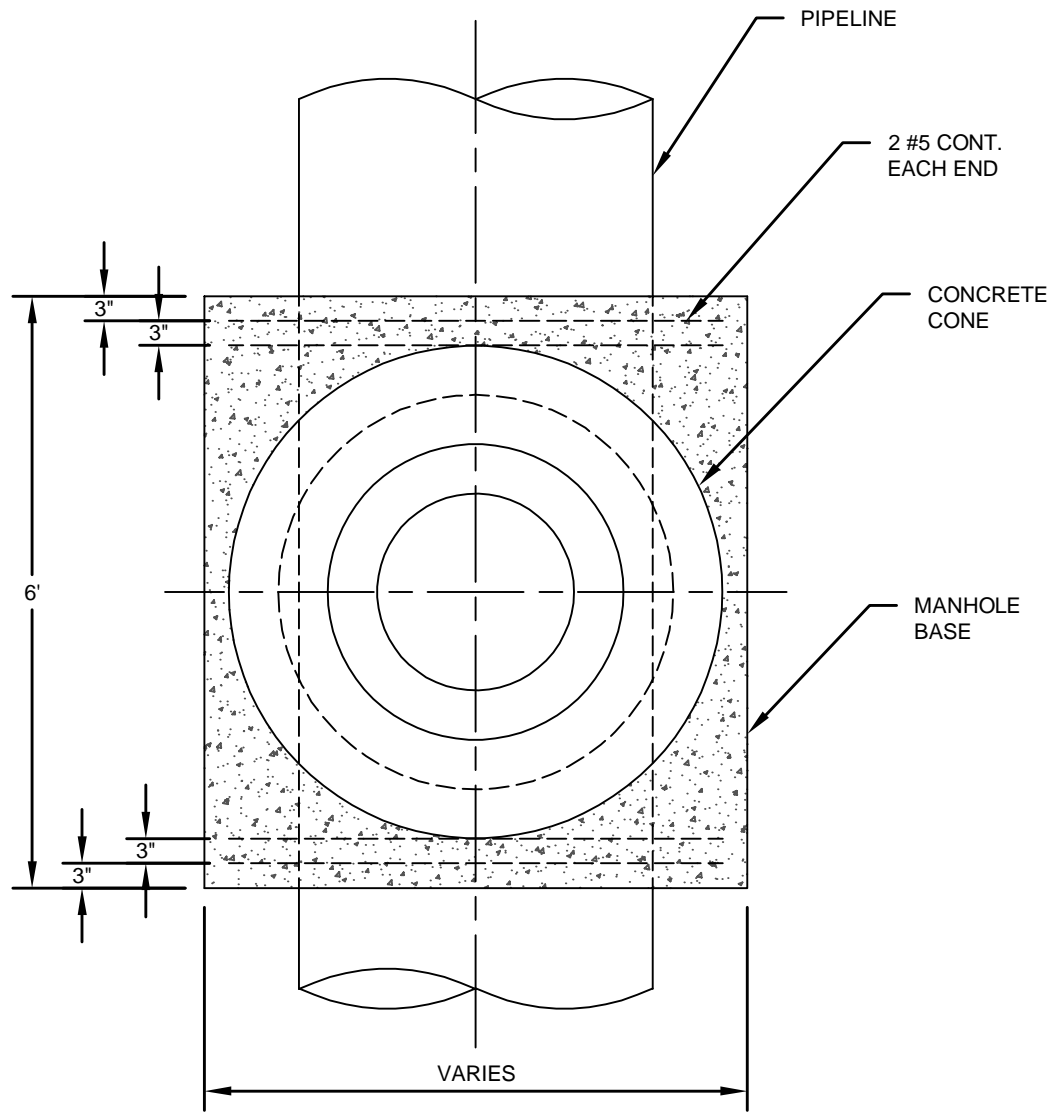

(SEE TABLE ON CWD STANDARD DETAIL)

**PLAN VIEW**  
**MANHOLE**  
**BASE**

**CHOWCHILLA**  
 WATER DISTRICT

**PRESSURE MANHOLE BASE DETAIL**

SCALE: NOT TO SCALE

**S-4**

PREPARED BY: GJF, PAD

APPROVED BY: BT

DATE ADOPTED: 5-11-2022

SHEET 1 OF 1

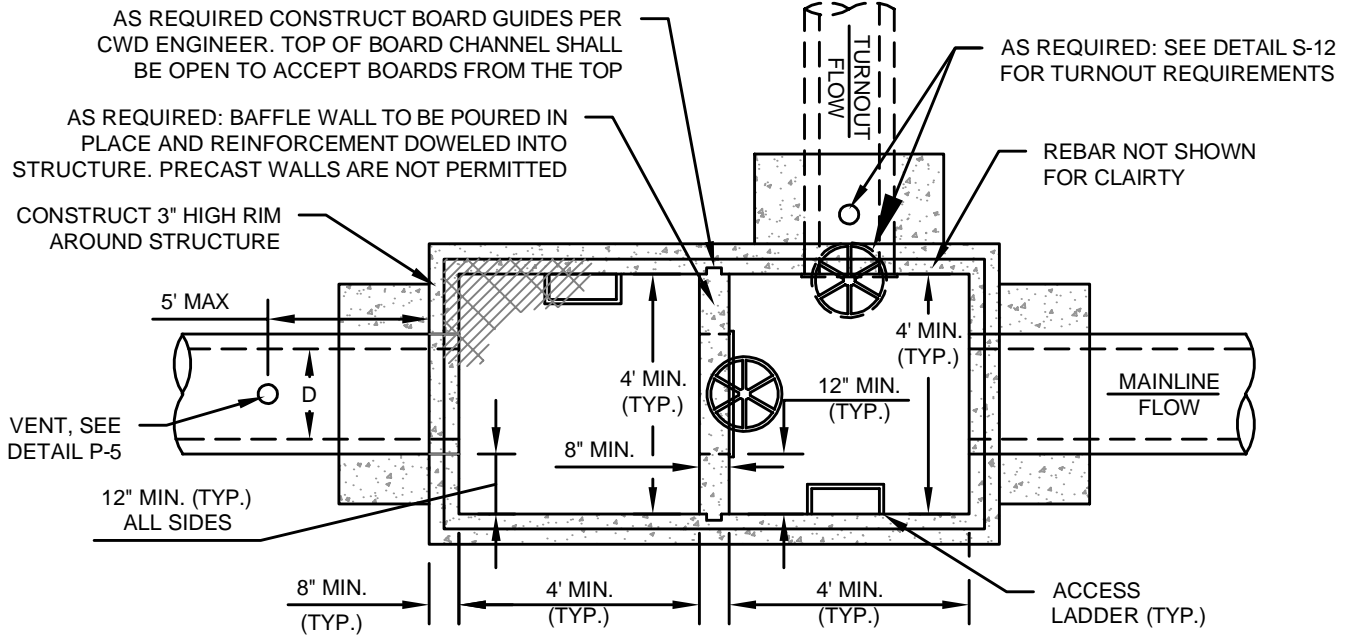

**PLAN**

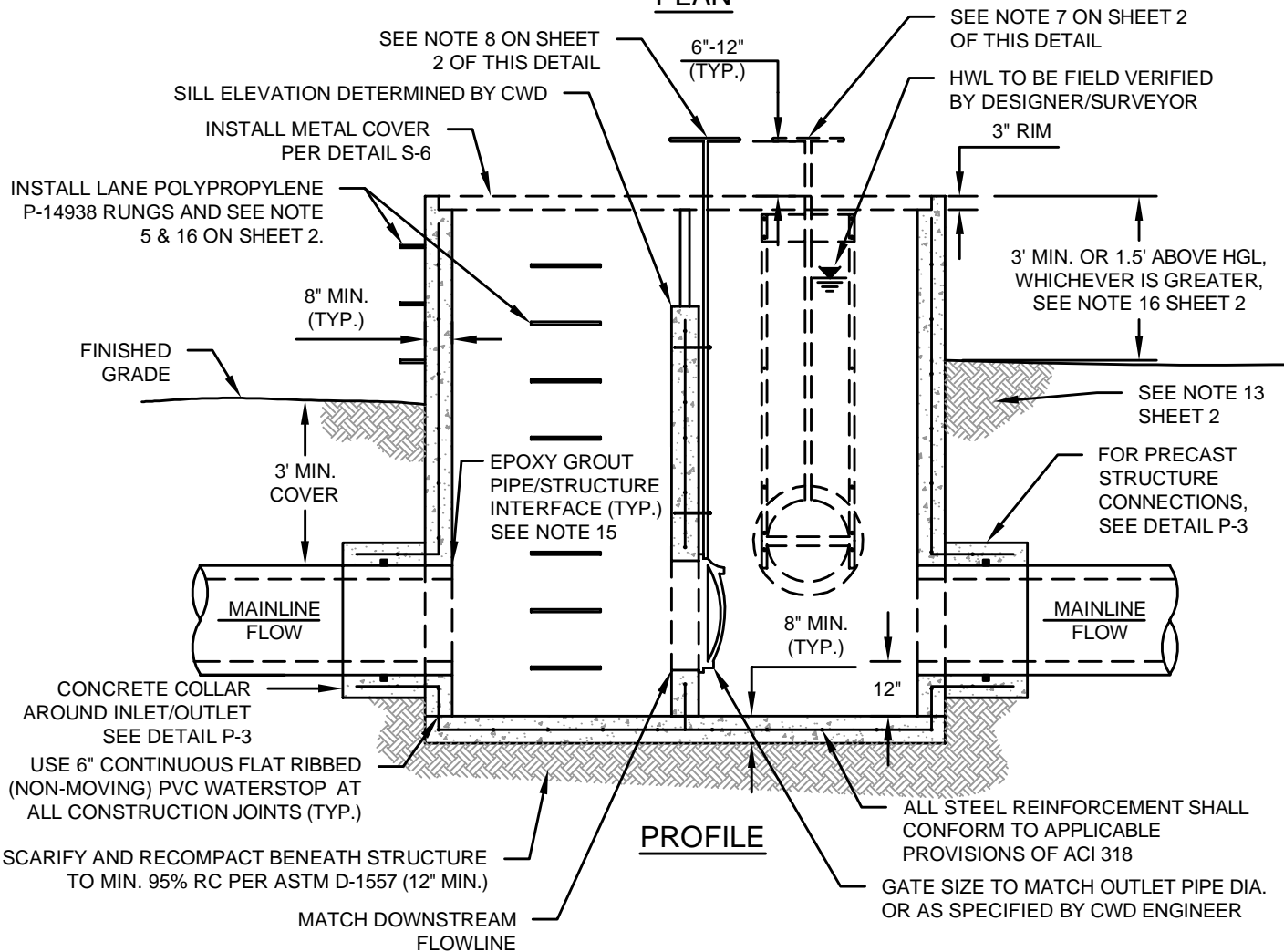

**PROFILE**

**CHOWCHILLA**  
WATER DISTRICT

**BACK UP STRUCTURE WITH BAFFLE WALL**

SCALE: NOT TO SCALE

**S-5**

PREPARED BY: GJF, PAD

APPROVED BY: BT

DATE ADOPTED: 5-11-2022

SHEET 1 OF 2

**STRUCTURE NOTES:**

1. IF CAST-IN-PLACE STRUCTURE IS USED, THEN STRUCTURE SHALL MEET ACI 318 REQUIREMENTS. THE CONTRACTOR SHALL SUBMIT PROPOSED CONCRETE AND STEEL REINFORCEMENT SPECIFICATIONS TO CWD FOR APPROVAL PRIOR TO CONSTRUCTION. ALL CAST-IN-PLACE JOINTS SHALL BE WATERTIGHT.
2. IF PRECAST STRUCTURE IS USED, THEN STRUCTURE SHALL MEET ACI 318 REQUIREMENTS. USE BUTYL OR SIMILAR WATERSTOP AROUND JOINT. JOINTS SHALL BE GROUTED ON THE INSIDE AND OUTSIDE. ALL JOINTS SHALL BE WATERTIGHT.
3. STRUCTURAL CONCRETE SHALL BE A MINIMUM OF 6-1/2 SACK (611 POUNDS OF PORTLAND CEMENT PER CUBIC YARD) WITH A MINIMUM 28-DAY COMPRESSIVE STRENGTH OF 3,500 PSI, WATER-CEMENT RATIO OF 0.45 (BY WEIGHT), AIR ENTRAINMENT OF 4% ± 1%, AND 4 INCH SLUMP AT PLACEMENT.
4. ALL CAST-IN-PLACE STRUCTURES SHALL INCLUDE FIBERCAST 500 OR EQUIVALENT CONCRETE FIBER REINFORCEMENT WITH FIBER LENGTHS BETWEEN 1.5 INCH TO 2 INCH. APPLICATION RATE TO BE A MINIMUM OF 1.5 POUNDS PER CUBIC YARD.
5. SEE CAL/OSHA STANDARDS FOR FIXED LADDER REQUIREMENTS.
6. CWD'S INSPECTOR MUST APPROVE ALL DESIGN CHANGES THAT OCCUR DUE TO UNEXPECTED FIELD CONDITIONS.
7. AS REQUIRED: INSTALL FRESNO VALVES AND CASTINGS GATE PER SPECIFICATIONS ON PLAN SHEET. RISING STEM REQUIRED FOR ALL GATES. FOR DIAMETER. ≤ 24 INCH USE TYPE W PRESSURE GATES. FOR DIAMETER. > 24 INCH USE MODEL 20-10C. CONTRACTOR SHALL SUBMIT SHOP DRAWING FOR CWD APPROVAL PRIOR TO ORDERING THE GATE.
8. AS REQUIRED: INSTALL 101C FRESNO VALVES AND CASTINGS GATE PER SPECIFICATIONS ON PLAN SHEET. RISING STEM REQUIRED FOR ALL GATES. CONTRACTOR SHALL SUBMIT SHOP DRAWING FOR CWD APPROVAL PRIOR TO ORDERING THE GATE. GATE SHALL BE GREATER THAN OR EQUAL TO DOWN STREAM PIPE SIZE OR AS DETERMINED BY CWD ENGINEER.
9. INSTALL FRESNO VALVES AND CASTINGS 101-C GATE PER SPECIFICATIONS ON PLAN SHEET. RISING STEM REQUIRED FOR ALL GATES.
10. ACCESS LADDERS TO BE PROVIDED AT UPSTREAM/DOWNSTREAM OF THE BAFFLE WALL.
11. GATES GREATER THAN OR EQUAL TO 48 INCH, ADD 3:1 GEAR REDUCER.
12. DIMENSIONS, REINFORCEMENT, AND NOTES ARE FOR DETAIL PURPOSES ONLY. A SCALED DRAWING SHALL BE PREPARED AND SUBMITTED WITH ALL PLAN SETS PRIOR TO CONSTRUCTION.
13. 93% MINIMUM COMPACTION REQUIRED AROUND STAND FOR A MINIMUM OF 5 FEET OR LIMITS OF DISTURBED SOIL, WHICHEVER IS GREATER.
14. DOWN STREAM AIR VENT MAY BE REQUIRED BY CWD ENGINEER.
15. CONSTRUCTION GROUT TO BE NON-SHRINK, CONSTRUCTION GRADE OR 5,000 PSI MINIMUM.
16. EXTERNAL LADDER COVER REQUIRED PER DETAIL 6-10 IF STRUCTURE IS MORE THAN 3 FEET ABOVE GRADE.



**BACK UP STRUCTURE WITH BAFFLE WALL  
NOTES**

**SCALE: NOT TO SCALE**

**S-5**

**PREPARED BY: GJF, PAD**

**APPROVED BY: BT**

**DATE ADOPTED: 5-11-2022**

**SHEET 2 OF 2**

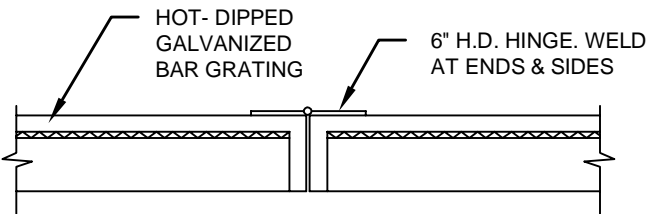
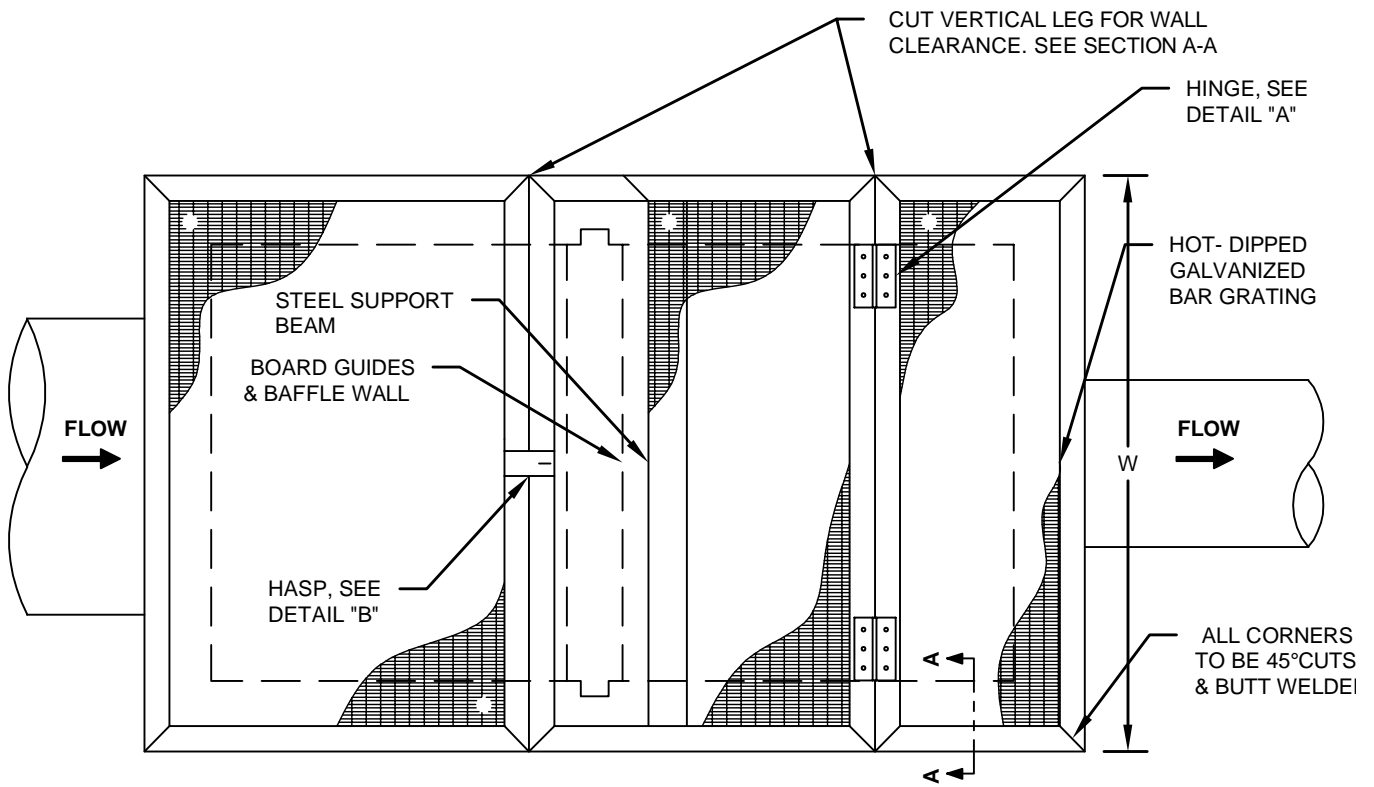

**DETAIL "A"**  
NTS

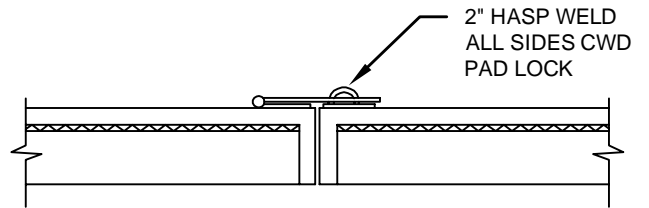

**DETAIL "B"**  
NTS

CRATING SEAT ANGLE  
1-1/2"X1-1/2"X3/16  
AROUND PERIMETER  
OF BOX STRUCTURE

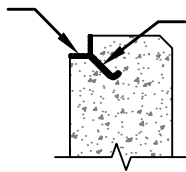

#4 BAR ANCHORS  
5 LONG @ 18" O.C.  
WELDED TO ANGLE

**BAR GRATING DETAIL**  
NTS

**NOTES**

1. FOR METAL COVER WITH HINGED SECTION FOR GATE & BOARD BACKUP.
2. CLEARANCE BETWEEN EDGE OF STRUCTURE & COVER SHALL BE 1/4" MIN. & 1/2" MAX ALL SIDES.
3. DRILL 5/8" X 2" DEEP HOLE IN SET CONCRETE & INSTALL DROP-IN ANCHOR W 1/2" Ø ALL THREAD BOLT. SECURE LID W/ 1/2" Ø WASHER & NUT. 8 REQ'D
4. ANY CHANGES OR DEVIATIONS REQUIRED BY FIELD CONDITIONS SHALL BE APPROVED BY CWD'S INSPECTOR.

**CHOWCHILLA**  
WATER DISTRICT

**BAR GRATING METAL COVER**

SCALE: NOT TO SCALE

**S-6**

PREPARED BY: GJF, PAD

APPROVED BY: BT

DATE ADOPTED: 5-11-2022

SHEET 1 OF 1



**CONSTRUCTION NOTES**

1. ALL BOARD SLOTS SHALL BE 2-1/2" X 2-1/2" GALVANIZED STEEL CHANNEL ANCHORED IN CONCRETE.
2. BOARDS SHALL BE 3" ROUGH CUT REDWOOD ALL BOARD SLOT SHALL CONFORM TO THIS STANDARD AND CWD STANDARD, CONCRETE SPECIFICATION.
3. THIS DETAIL DOES NOT SPECIFY CONCRETE THICKNESS OR REINFORCEMENT SIZE WHICH SHOULD BE DESIGNED SEPARATELY.

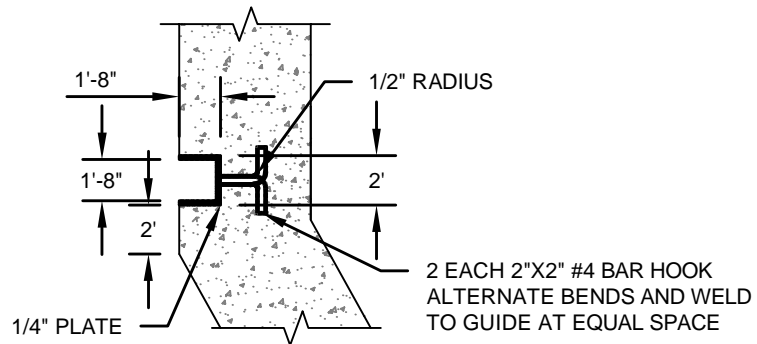

**BOARD GUIDE DETAIL**

NTS

**CHOWCHILLA**  
WATER DISTRICT

**BOARD SLOT DETAIL**

SCALE: NOT TO SCALE

**S-7**

PREPARED BY: GJF, PAD

APPROVED BY: BT

DATE ADOPTED: 5-11-2022

SHEET 1 OF 1

**CONSTRUCTION NOTES**

1. ALL JOINTS BETWEEN CONCRETE POURS SHALL BE APPROVED CONSTRUCTION JOINT. ALL CONSTRUCTION JOINTS SHALL CONFORM TO THIS STANDARD AND CWD STANDARD DRAWING, CONCRETE SPECIFICATION.
2. CONSTRUCTION JOINTS SHALL BE PLACED AS SHOWN ON THE PLANS OR AS PRE-APPROVED BY THE CWD ENGINEER. JOINTS SHALL BE THOROUGHLY CLEANED AND LAITANCE REMOVED BEFORE A NEW POUR IS MADE. EACH JOINT SHALL BE WETTED IMMEDIATELY BEFORE THE PLACMENT OF NEW CONCRETE
3. WATER STOP SHALL BE "MIRASTOP" BENTONITE CLAY EXPANSIVE WATERSTOP WITH ALL WEATHER PRIMER (AWP) OR EQUIVALENT, AS APPROVED BY THE CWD ENGINEER.
4. REINFORCING STEEL SHALL JOIN THE CONCRETE BETWEEN POURS WITH MINIMUM OVERLAP CONFORMING THE CWD STANDARD DRAWING, CONCRETE SPECIFICATION.
5. THIS DETAIL DOES NOT SPECIFY CONCRETE THICKNESS OR REINFORCEMENT SIZE WHICH SHOULD BE DESIGNED SEPARATELY.

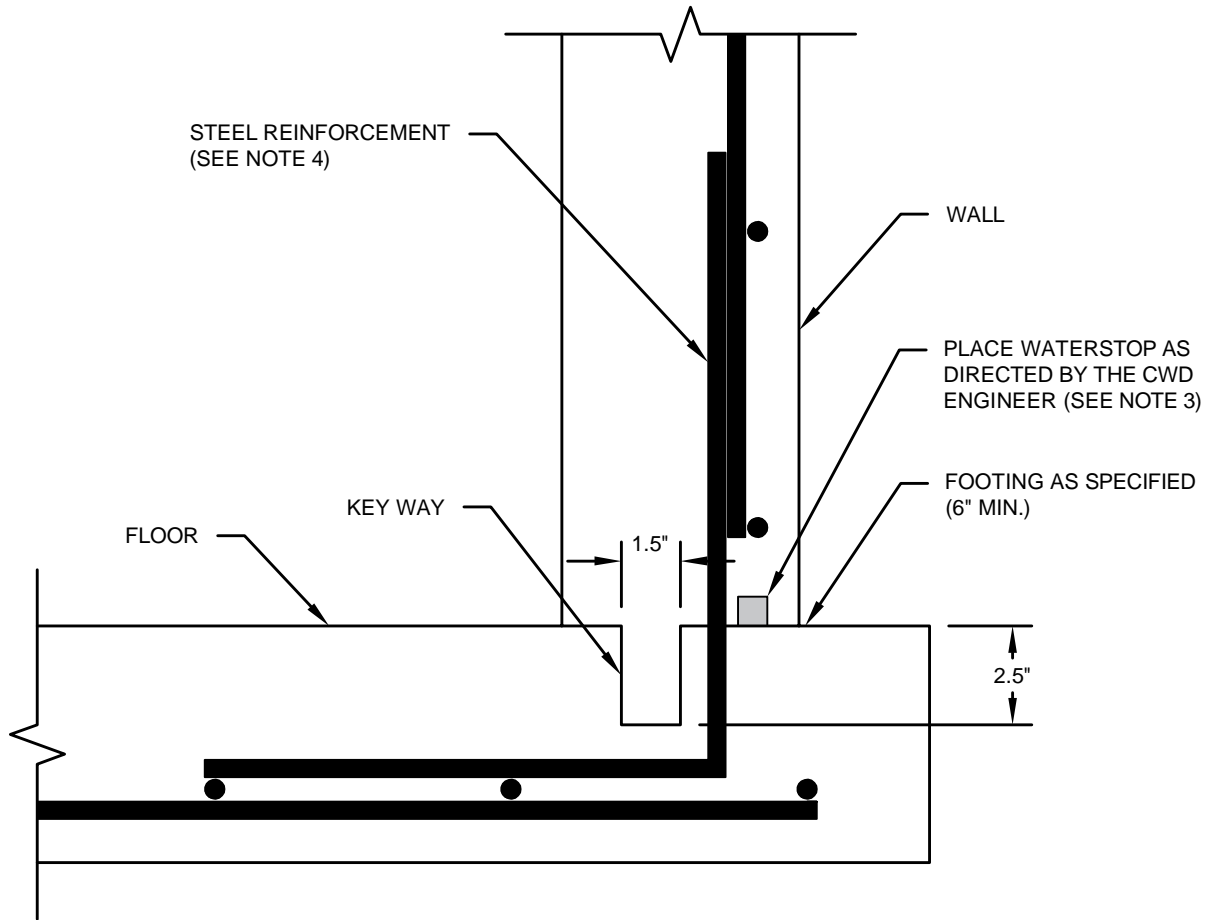

|                                                                                     |                 |                                                |              |
|-------------------------------------------------------------------------------------|-----------------|------------------------------------------------|--------------|
|  |                 | <b>CONSTRUCTION JOINT DETAIL WALL TO FLOOR</b> |              |
|                                                                                     |                 | SCALE: NOT TO SCALE                            | S-8          |
| PREPARED BY: GJF, PAD                                                               | APPROVED BY: BT | DATE ADOPTED: 5-11-2022                        | SHEET 1 OF 1 |

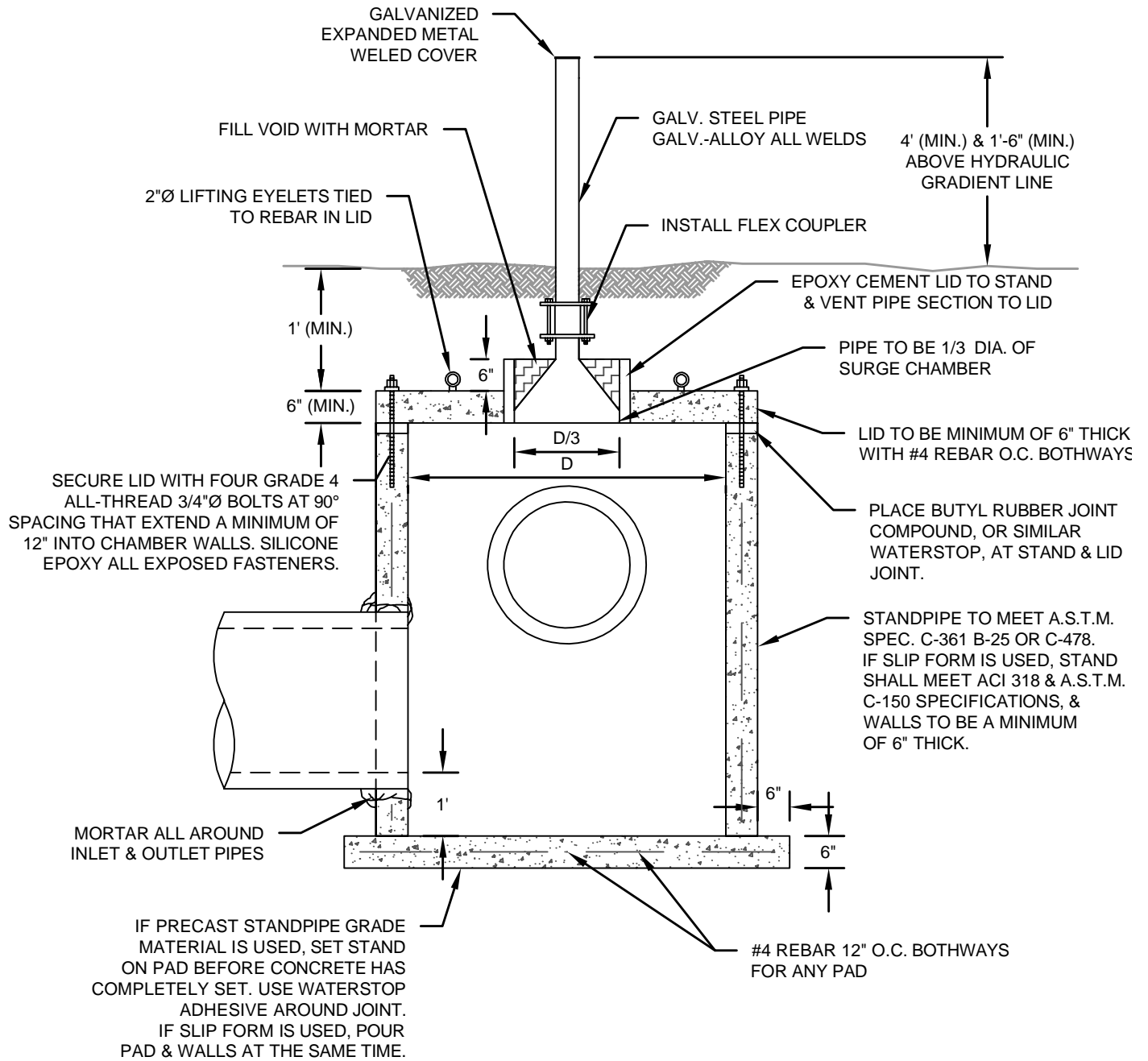

**NOTES**

1. CWD'S INSPECTOR MUST APPROVE ANY CHANGES THAT OCCUR DUE TO FIELD CONDITIONS.
2. ALL CONCRETE SHALL BE 6.0 SACK MIX, 0.46 WATER-TO-CEMENT RATIO, CONTAIN 2 POUNDS PER CUBIC YARD OF 2-INCH LONG FIBRILLATED MD SYNTHETIC FIBER & HAVE A MINIMUM OF 3,000 PSI COMPRESSIVE STRENGTH AT 28 DAYS.
3. A MINIMUM OF 5" OF CONCRETE IS REQUIRED BETWEEN THE TOP OF PIPE & THE BOTTOM OF THE LID.

**CHOWCHILLA**  
WATER DISTRICT

**PIPE SURGE CHAMBER WITH CONCRETE LID**

SCALE: NOT TO SCALE

**S-9**

PREPARED BY: GJF, PAD

APPROVED BY: BT

DATE ADOPTED: 5-11-2022

SHEET 1 OF 1

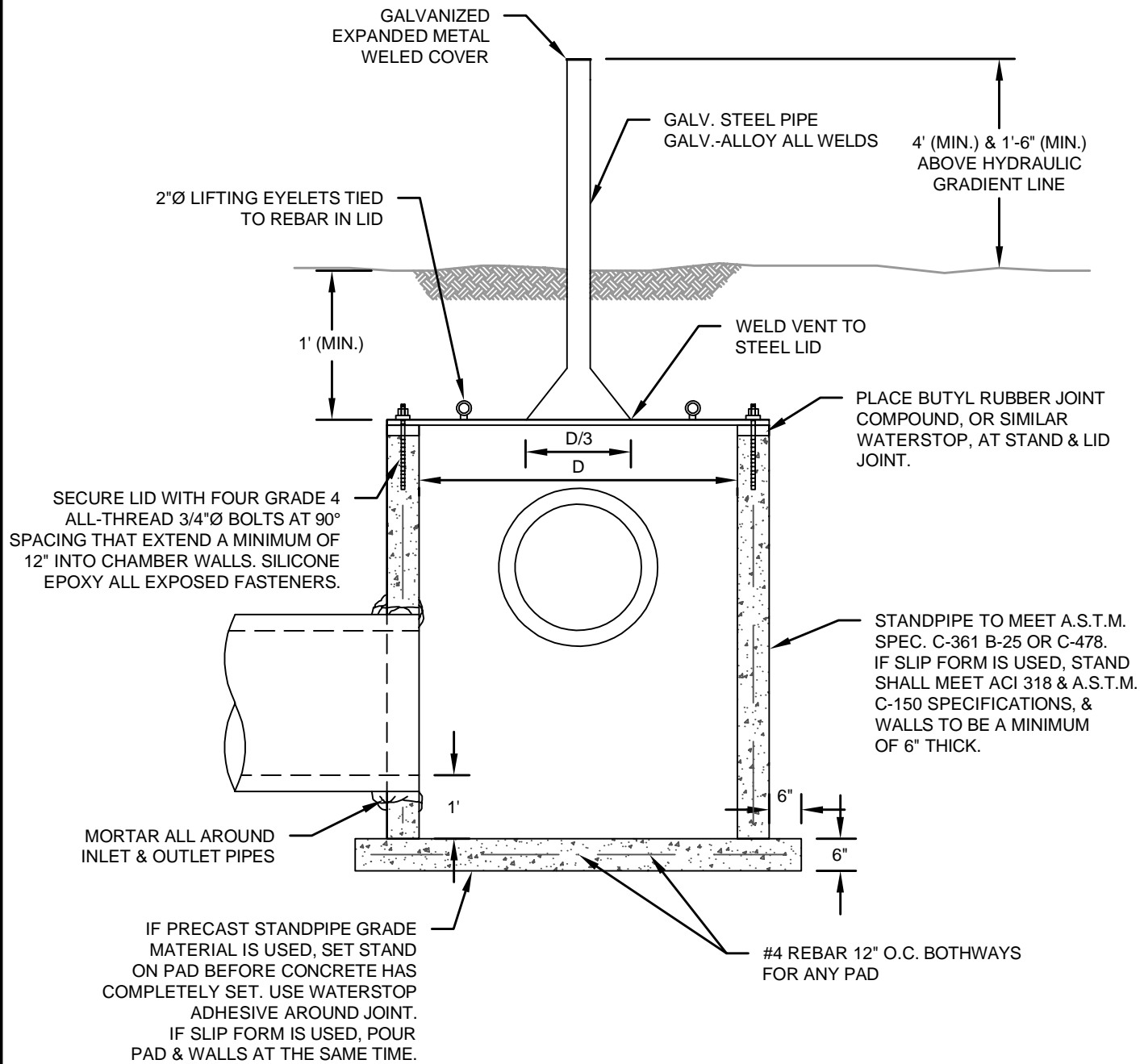

**NOTES**

1. CWD'S INSPECTOR MUST APPROVE ANY CHANGES THAT OCCUR DUE TO FIELD CONDITIONS.
2. ALL CONCRETE SHALL BE 6.0 SACK MIX, 0.46 WATER-TO-CEMENT RATIO, CONTAIN 2 POUNDS PER CUBIC YARD OF 2-INCH LONG FIBRILLATED MD SYNTHETIC FIBER & HAVE A MINIMUM OF 3,000 PSI COMPRESSIVE STRENGTH AT 28 DAYS.
3. A MINIMUM OF 5" OF CONCRETE IS REQUIRED BETWEEN THE TOP OF PIPE & THE BOTTOM OF THE LID.
4. ALL VENTS SHALL BE WELDED GALVANIZED STEEL PIPE. NO PIPE FITTINGS WILL BE ALLOWED.

**CHOWCHILLA**  
WATER DISTRICT

**PIPE SURGE CHAMBER WITH STEEL LID**

SCALE: NOT TO SCALE

**S-10**

PREPARED BY: GJF, PAD

APPROVED BY: BT

DATE ADOPTED: 5-11-2022

SHEET 1 OF 1

CONSTRUCT BOARD GUIDES PER DETAIL 5-10.  
TOP OF BOARD CHANNEL SHALL BE OPEN TO  
ACCEPT BOARDS FROM THE TOP

AS REQUIRED: BAFFLE WALL TO BE POURED  
IN PLACE AND DOWELED INTO STRUCTURE  
PRECAST WALLS ARE NOT PERMITTED

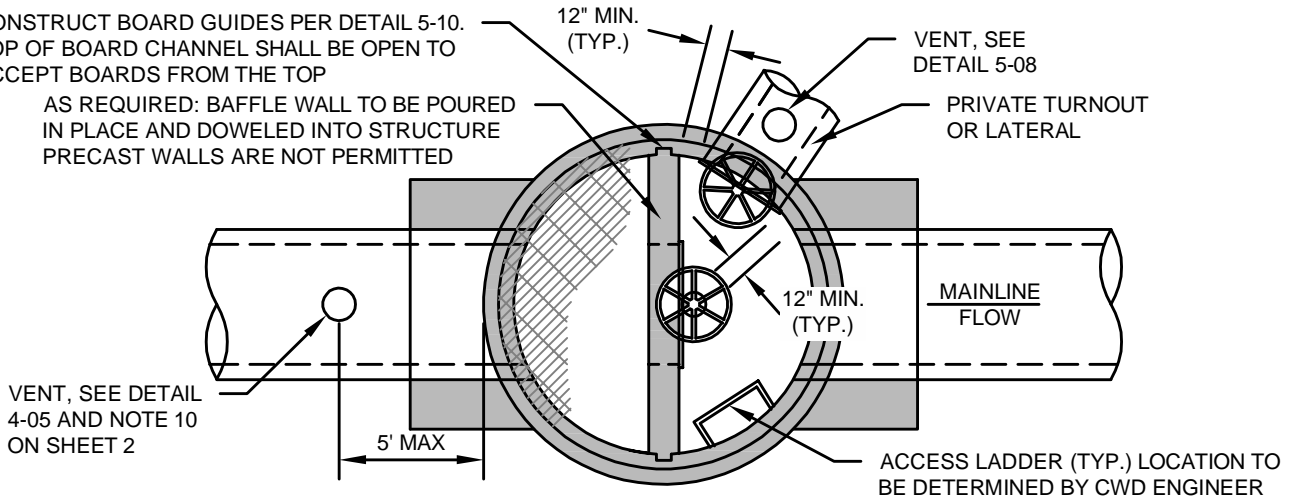

**PLAN VIEW**

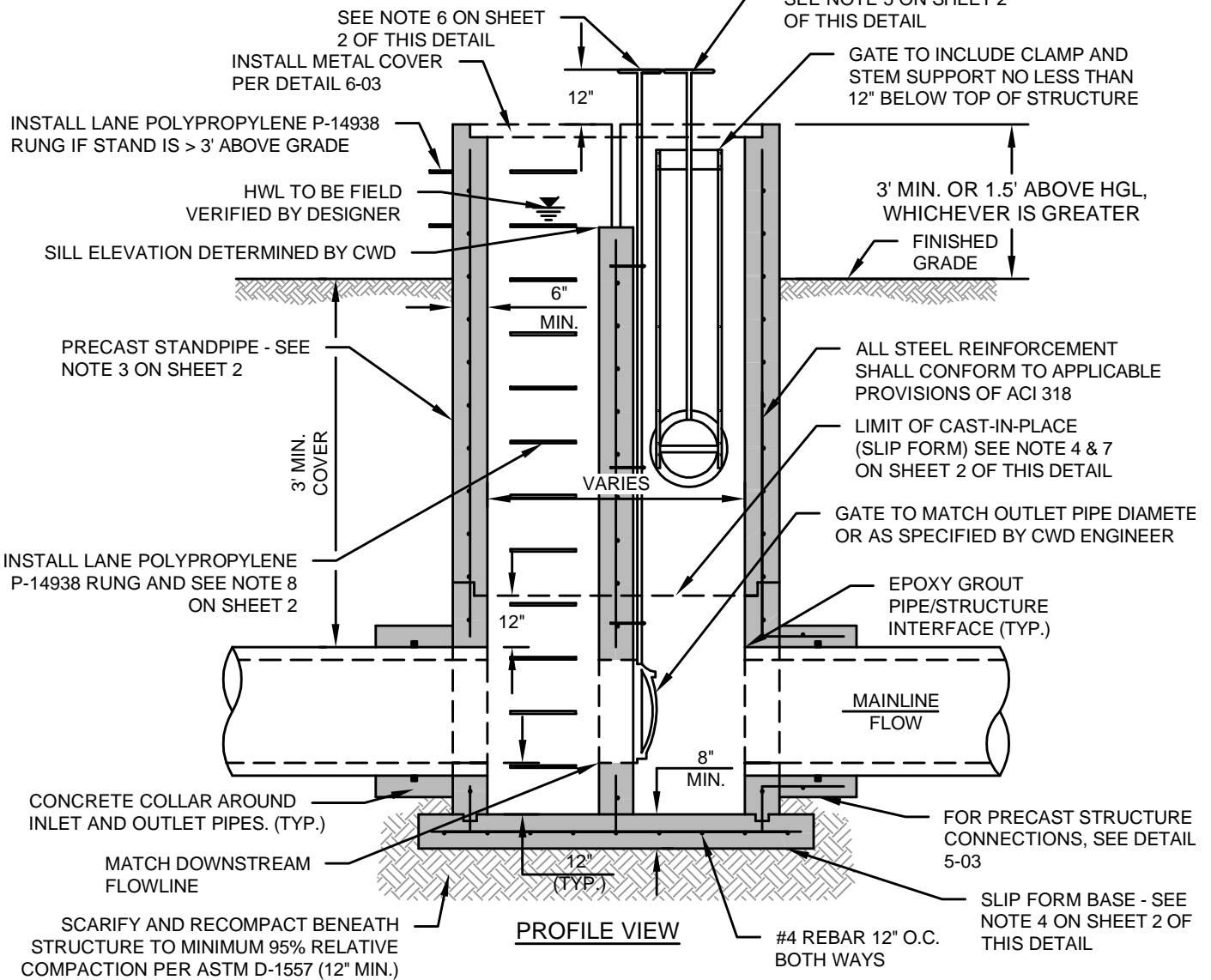

**PROFILE VIEW**

**CHOWCHILLA**  
WATER DISTRICT

**GATE-SURGE CHAMBER STAND**

SCALE: NOT TO SCALE

**S-11**

PREPARED BY: GJF, PAD

APPROVED BY: BT

DATE ADOPTED: 5-11-2022

SHEET 1 OF 2

**STRUCTURE NOTES:**

1. STRUCTURAL CONCRETE SHALL BE A MINIMUM OF 6-1/2 SACK (611 POUNDS OF PORTLAND CEMENT PER CUBIC YARD) WITH A MINIMUM 28-DAY COMPRESSIVE STRENGTH OF 3,500 PSI, WATER-CEMENT RATIO OF 0.45 (BY WEIGHT), AIR ENTRAINMENT OF 4% ± 1%, AND 4 INCH SLUMP AT PLACEMENT.
2. ALL CAST-IN-PLACE (SLIP FORM) STRUCTURES SHALL INCLUDE FIBERCAST 500 OR EQUIVALENT CONCRETE FIBER REINFORCEMENT WITH FIBER LENGTHS BETWEEN 1.5 INCH (1.5") TO 2 INCH (2"). APPLICATION RATE TO BE A MINIMUM OF 1.5 POUNDS PER CUBIC YARD.
3. IF PRECAST STANDPIPE IS USED, SET STAND ON PAD BEFORE CONCRETE HAS COMPLETELY SET. USE RAMNEC BUTYL RUBBER JOINT COMPOUND AROUND JOINT OR APPROVED EQUIVALENT WATERSTOP. STANDPIPE SHALL MEET ASTM C-478. ALL JOINTS SHALL BE WATERTIGHT.
4. IF CAST-IN-PLACE (SLIP FORM) IS USED FOR STANDPIPE, BASE SHALL MEET ACI 318 AND ASTM C-150 SPECIFICATIONS. WALLS SHALL BE MIN. 8 INCH (8") THICK. POUR PAD AND WALLS AT THE SAME TIME. ALL JOINTS SHALL BE WATERTIGHT.
5. INSTALL FRESNO VALVES AND CASTINGS GATE PER SPECIFICATIONS ON PLAN SHEET. RISING STEM REQUIRED FOR ALL GATES. FOR DIAMETER. ≤ 24 INCH (24") USE TYPE W PRESSURE GATES. FOR DIAMETER. > 24 INCH (24") USE MODEL 20-10C. .
6. INSTALL 101C FRESNO VALVES AND CASTINGS GATE PER SPECIFICATIONS ON PLAN SHEET. RISING STEM REQUIRED FOR ALL GATES. CONTRACTOR SHALL SUBMIT SHOP DRAWING FOR CWD APPROVAL PRIOR TO ORDERING THE GATE.
7. TOP OF SLIP FORM SHALL BE CAST WITH APPROPRIATE IMPRESSION RINGS.
8. SEE CAL/OSHA STANDARDS FOR FIXED LADDER REQUIREMENTS.
9. CWD'S INSPECTOR MUST APPROVE ANY CHANGES THAT MAY OCCUR DUE TO FIELD CONDITIONS.
10. DOWNSTREAM AIR VENT MAY BE REQUIRED BY CWD ENGINEER.



**GATE-SURGE CHAMBER STAND NOTES**

SCALE: NOT TO SCALE

**S-11**

PREPARED BY: GJF, PAD

APPROVED BY: BT

DATE ADOPTED: 5-11-2022

SHEET 2 OF 2

**CONSTRUCTION NOTES**

1. ALL CONCRETE POURS FOR UPRIGHT DELIVERY STRUCTURES SHALL BE MONOLITHIC (ENTIRE STRUCTURE POURED AT ONCE).
2. DELIVERY GATES SHALL CONFORM TO CWD STANDARD.
3. REINFORCED CONCRETE SHALL CONFORM TO CWD STANDARD, CONCRETE SPECIFICATION.

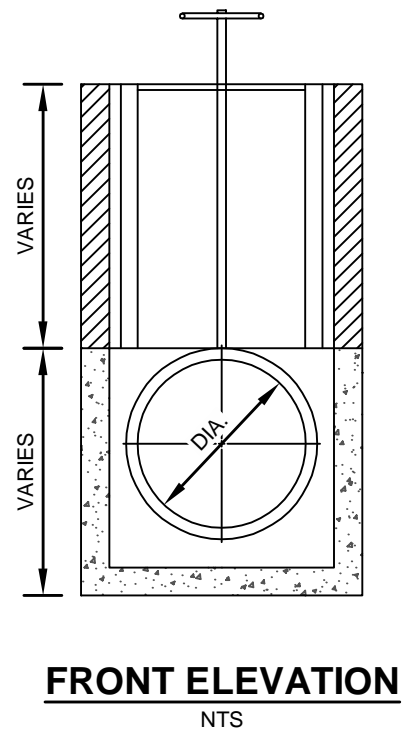
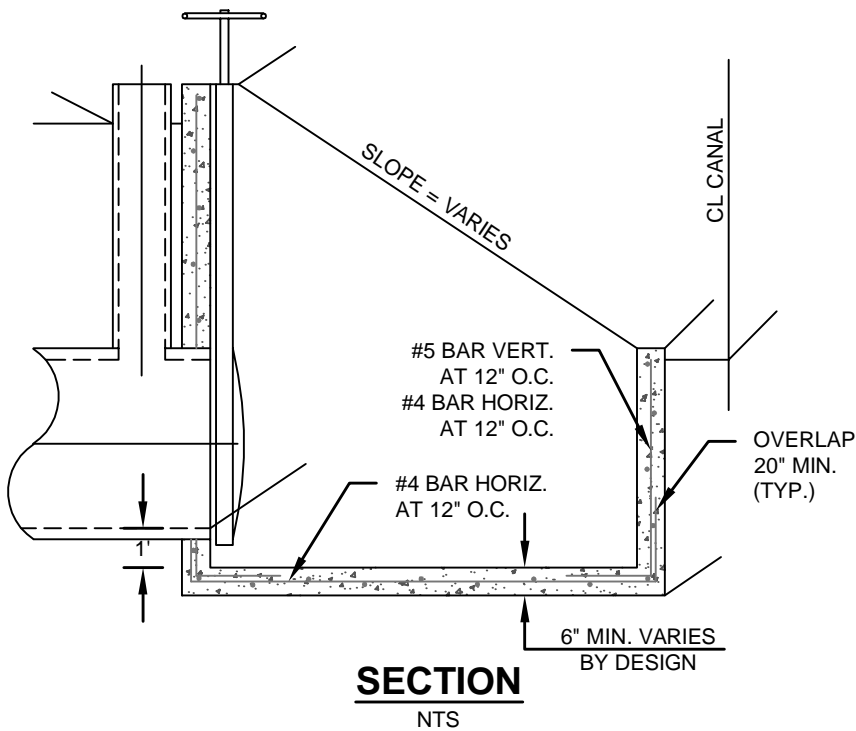
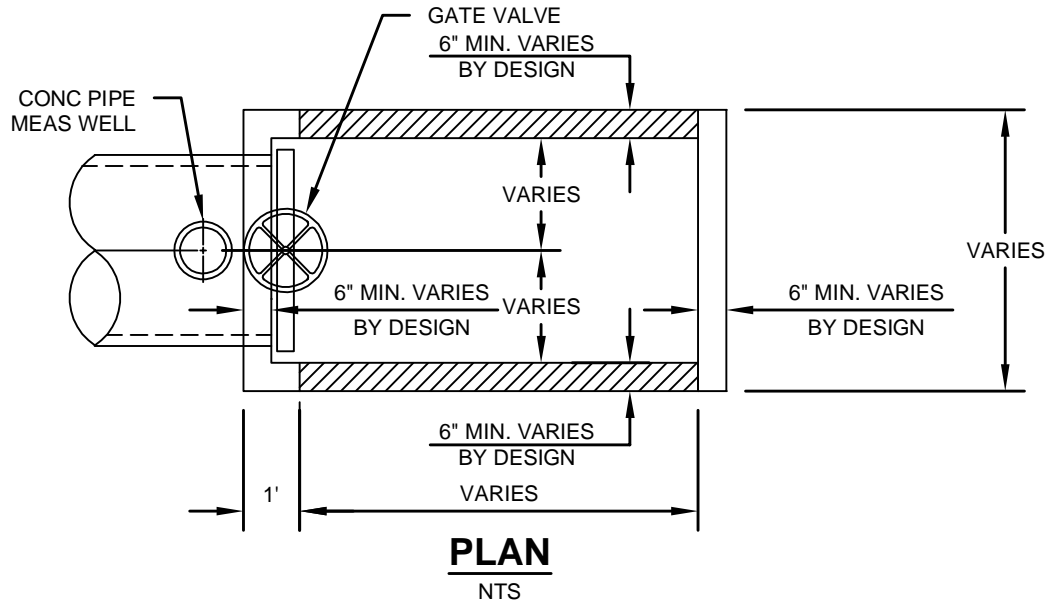

**CHOWCHILLA**  
WATER DISTRICT

**UPRIGHT DELIVERY STRUCTURE**

SCALE: NOT TO SCALE

**S-12**

PREPARED BY: GJF, PAD

APPROVED BY: BT

DATE ADOPTED: 5-11-2022

SHEET 1 OF 1

**NOTE**

SEE SHEET 3 FOR CONSTRUCTION NOTES.

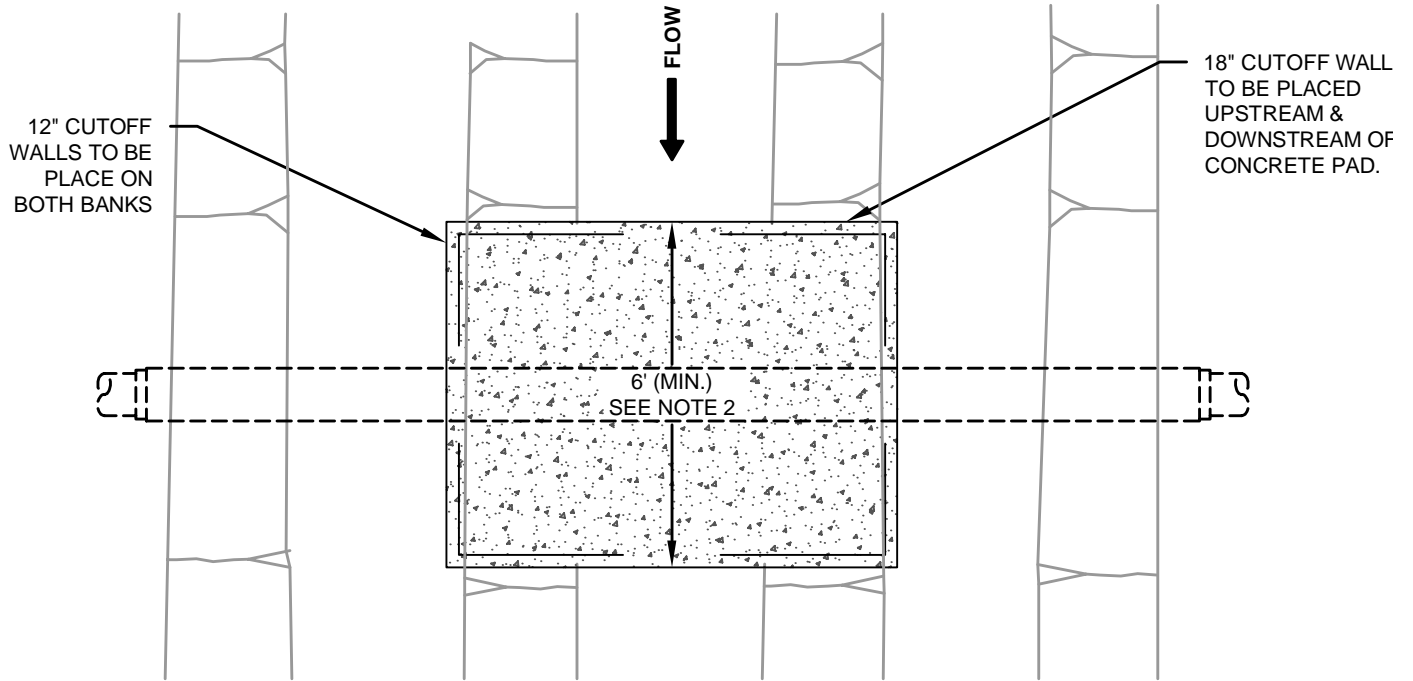

**PLAN VIEW**

NTS

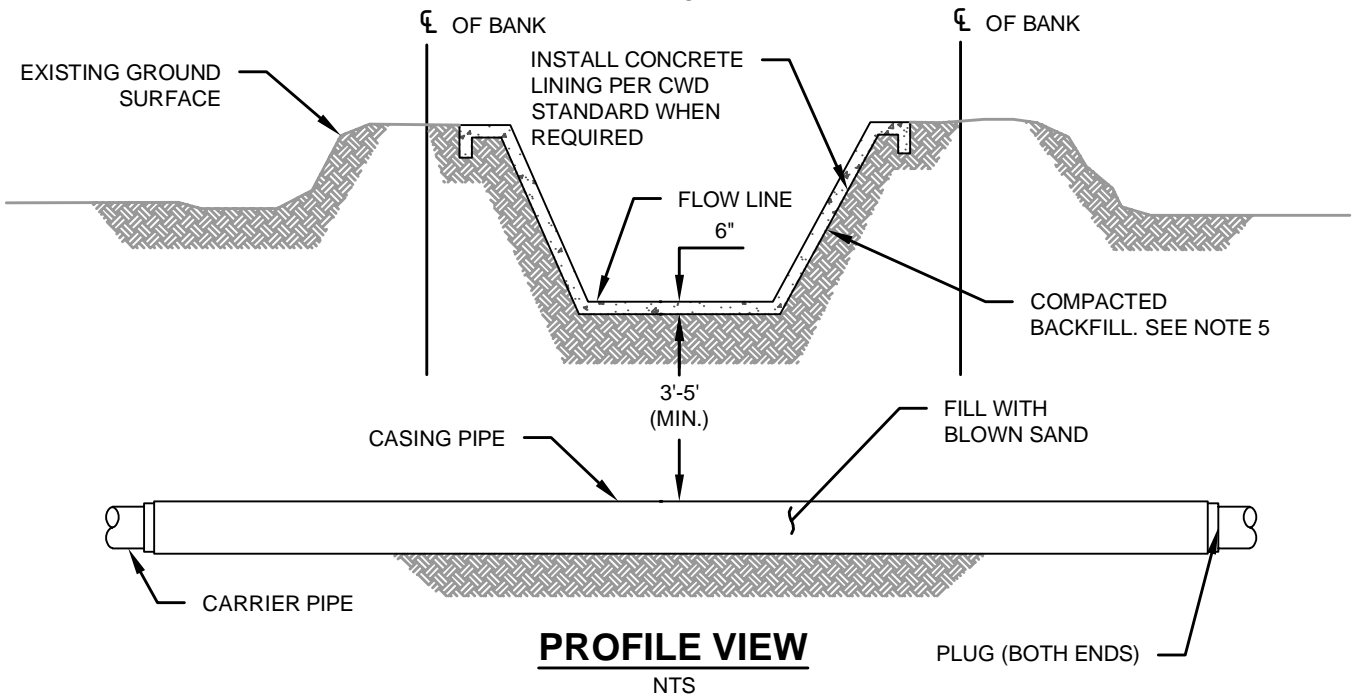

**PROFILE VIEW**

NTS

**CHOWCHILLA**  
WATER DISTRICT

UTILITY CROSSING OPEN CUT DETAILS

SCALE: NOT TO SCALE

**U-1**

PREPARED BY: GJF, PAD

APPROVED BY: BT

DATE ADOPTED: 5-11-2022

SHEET 1 OF 3



**NOTE**

SEE SHEET 3 FOR CONSTRUCTION NOTES.

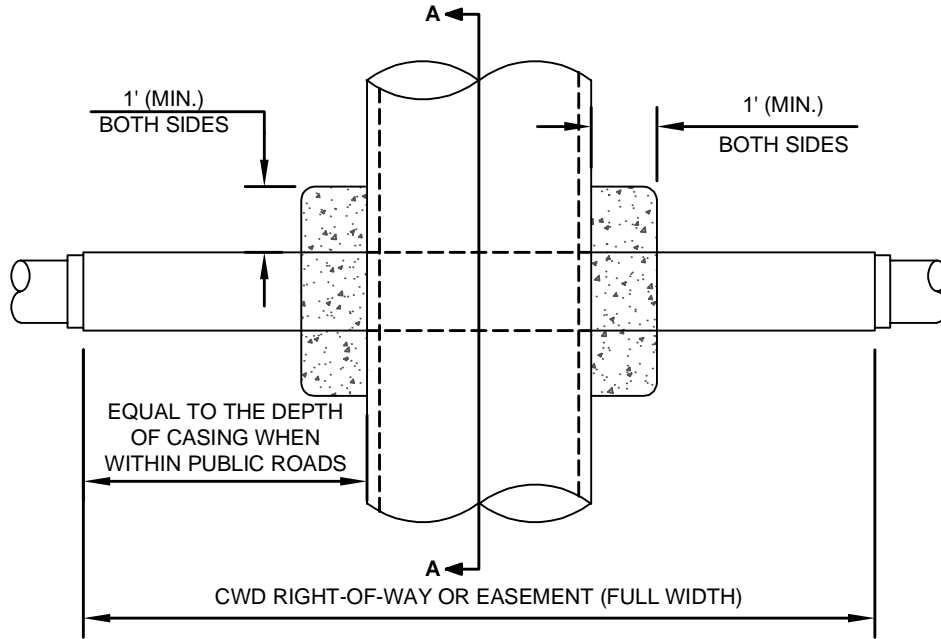

**PLAN**  
NTS

EXISTING GROUND SURFACE

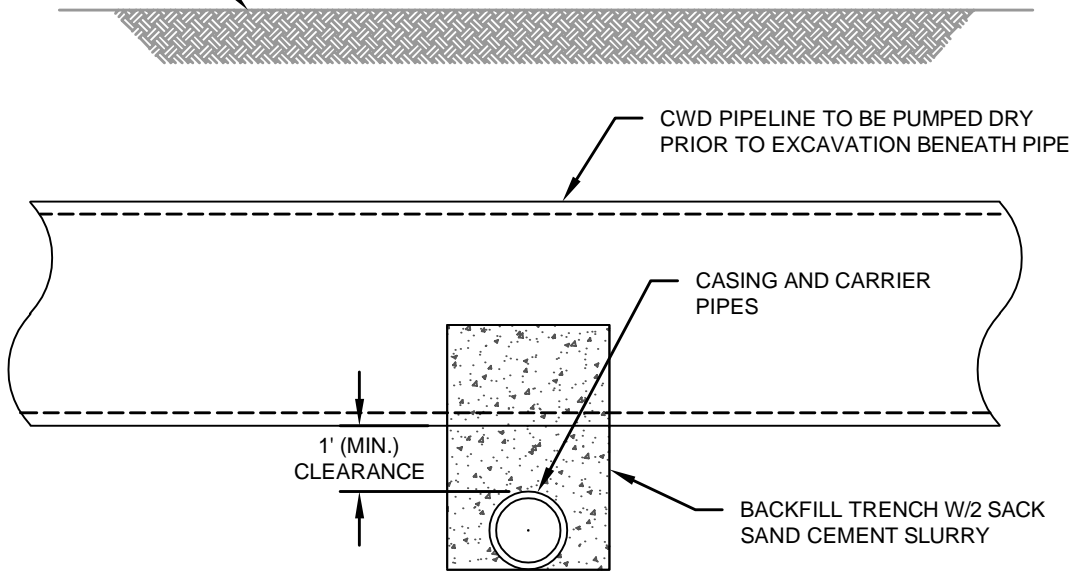

**SECTION A-A**  
**PIPE UNDER CWD PIPELINE**

**CHOWCHILLA**  
WATER DISTRICT

UTILITY CROSSING OPEN CUT DETAILS

SCALE: NOT TO SCALE

**U-1**

PREPARED BY: GJF, PAD

APPROVED BY: BT

DATE ADOPTED: 5-11-2022

SHEET 2 OF 3

**UTILITY CROSSING OPEN CUT NOTES:**

1. WHENEVER ANY PROPOSED UTILITY IS TO CROSS EXISTING CWD FACILITIES (PIPELINE, UNLINED DITCH OR LINED CANAL) LYING WITHIN CWD RIGHT-OF-WAY OR CWD EASEMENTS, IT SHALL BE ACCOMPLISHED BY OPEN CUT AS SPECIFIED IN CWD STANDARD, UTILITY CROSSING OPEN CUT, OR HORIZONTAL AUGER BORING OF A STEEL CASING PIPE RUNNING CONTINUOUSLY THE FULL WIDTH OF THE PROPERTY OR EASEMENT AS SPECIFIED IN CWD STANDARD, UTILITY CROSSING BORING DETAILS. WHENEVER ANY PROPOSED UTILITY IS TO CROSS EXISTING CWD FACILITIES LYING WITHIN A NON-EXCLUSIVE EASEMENT OR PUBLIC RIGHT-OF-WAY, IT SHALL BE ACCOMPLISHED AS STATED ABOVE, EXCEPT THAT THE MINIMUM LENGTH OF THE CASING PIPE SHALL BE AS SHOWN ON SHEET 3 (WITHIN PUBLIC ROADS).
2. CONCRETE LINING FOR OPEN CUT INSTALLATIONS WHEN REQUIRED. REFER TO CWD STANDARD, TYPICAL CROSS SECTION FOR CONCRETE LINING.
3. CWD INSPECTOR TO DETERMINE LIMITS OF DISTURBED SOIL.
4. NO VENT OR STRUCTURES TO BE LOCATED WITHIN THE CANAL EASEMENTS.
5. PIPELINE SHALL BE BACKFILLED IN MAXIMUM OF 8-INCH LIFTS AND COMPACTED TO 90% RELAVTIVE COMPACTION (ASTM D-1557), ACCORDING TO CWD STANDARD, PIPELINE TRENCH BACKFILL DETAIL.
6. THIS DETAIL IS INTENDED TO SHOW CANAL/PIPELINE CROSSING DETAILS ONLY. ADDITIONAL CARRIER PIPE ANGLES, THRUST BLOCKS, VALVES, AND APPURTENANCES MAY BE REQUIRED FOR PROPER SYSTEM DESIGN.
7. CASING PIPES SHALL BE FILLED WITH BLOWN SAND AND PLUGGED AT EACH END AS DETERMINED BY THE CWD ENGINEER.
8. THE INSIDE DIAMETER OF THE CASING PIPE SHALL BE AS LARGE AS NECESSARY FOR THE INSTALLATION OF THE CARRIER PIPE AND SKIDS. IN NO CASE SHALL IT BE LESS THAN 6" LARGER THAN THE OUTSIDE DIAMETER OF THE CARRIER PIPE. CASING PIPES SHALL BE MINIMUM SCHEDULE 40 WELDED STEEL PIPE AND SHALL BE COATED WITH A MINIMUM OF 2 COATS OF COAL TAR EPOXY. COATING MUST BE ALLOWED TO DRY BEFORE BACKFILL.

CASING THICKNESS:

MINIMUM THICKNESS

1/4"

3/8"

1/2"

BY DESIGN

9. CARRIER PIPES SHALL BE SUITABLE FOR TRANSPORTING THE PRODUCT INTENDED AND SHALL HAVE COMPRESSION SEALING JOINTS.
10. CASING PIPES FOR CARRIER PIPES TRANSPORTING PRODUCTS UNDER PRESSURE SHALL BE SEALED (PLUGGED) AT EACH END AND A VENT PIPE SHALL BE INSTALLED IF REQUIRED BY THE CWD ENGINEER. CASING PIPES FOR GRAVITY FLOW CARRIER PIPES NEED ONLY TO BE SEALED (PLUGGED) AT EACH END. CASING PIPES CARRYING ELECTRICAL CONDUCTORS SHALL BE GROUNDED WITH A GROUNDING ROD IN ACCORDANCE WITH THE NATIONAL ELECTRIC CODE.



**UTILITY CROSSING OPEN CUT DETAILS  
NOTES**

SCALE: NOT TO SCALE

**U-1**

PREPARED BY: GJF, PAD

APPROVED BY: BT

DATE ADOPTED: 5-11-2022

SHEET 3 OF 3

**NOTE**

SEE SHEET 3 FOR CONSTRUCTION NOTES.

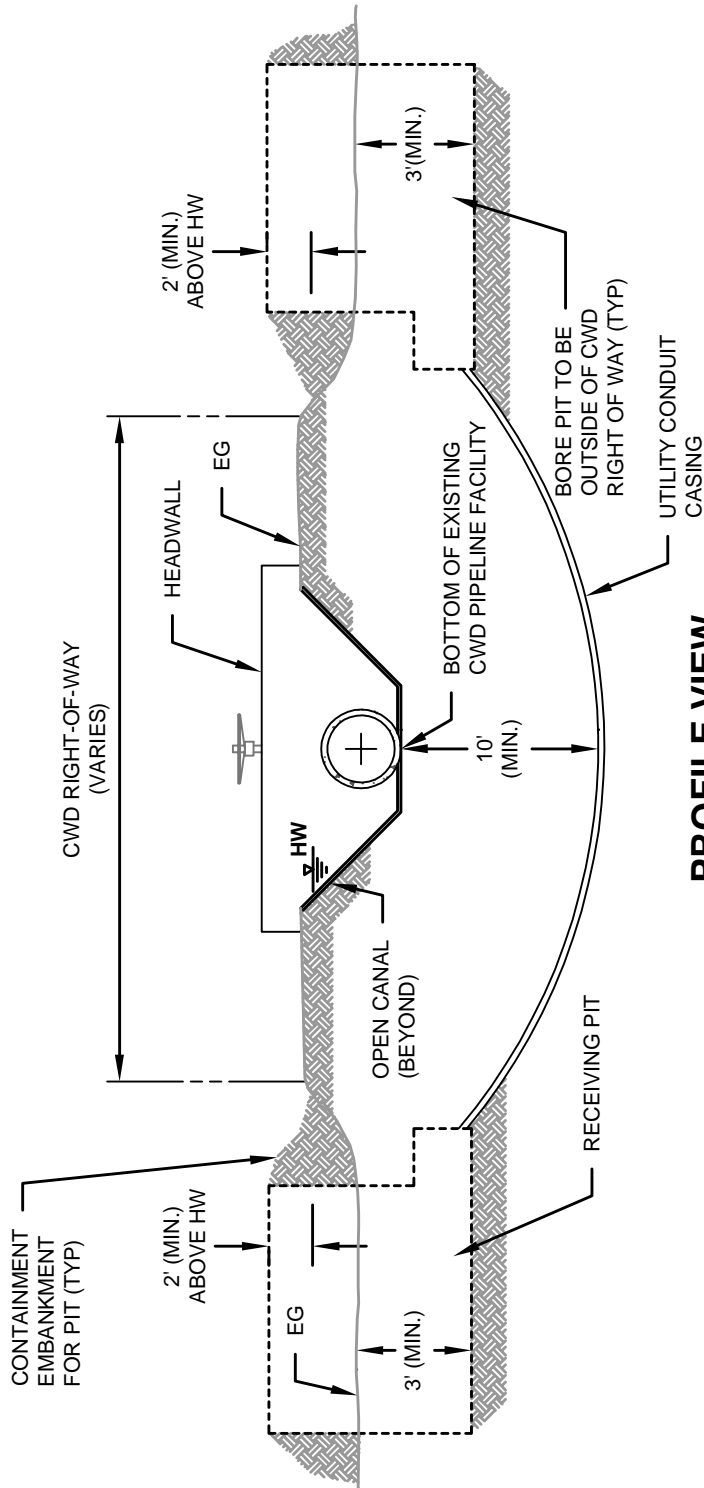

**PROFILE VIEW**

NTS

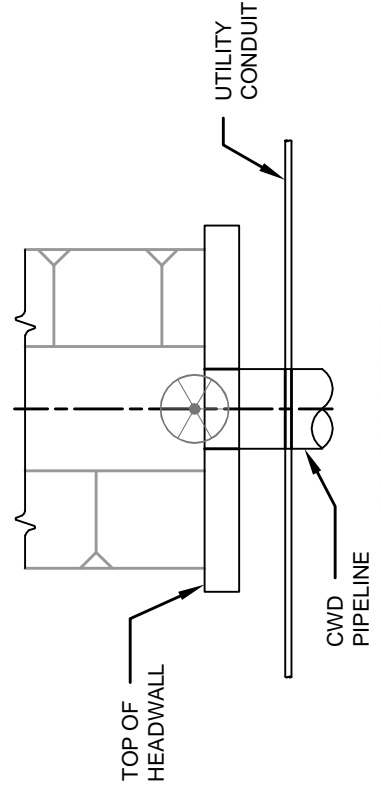

**PLAN VIEW**

NTS

**NOTE**

SEE SHEET 3 FOR CONSTRUCTION NOTES.

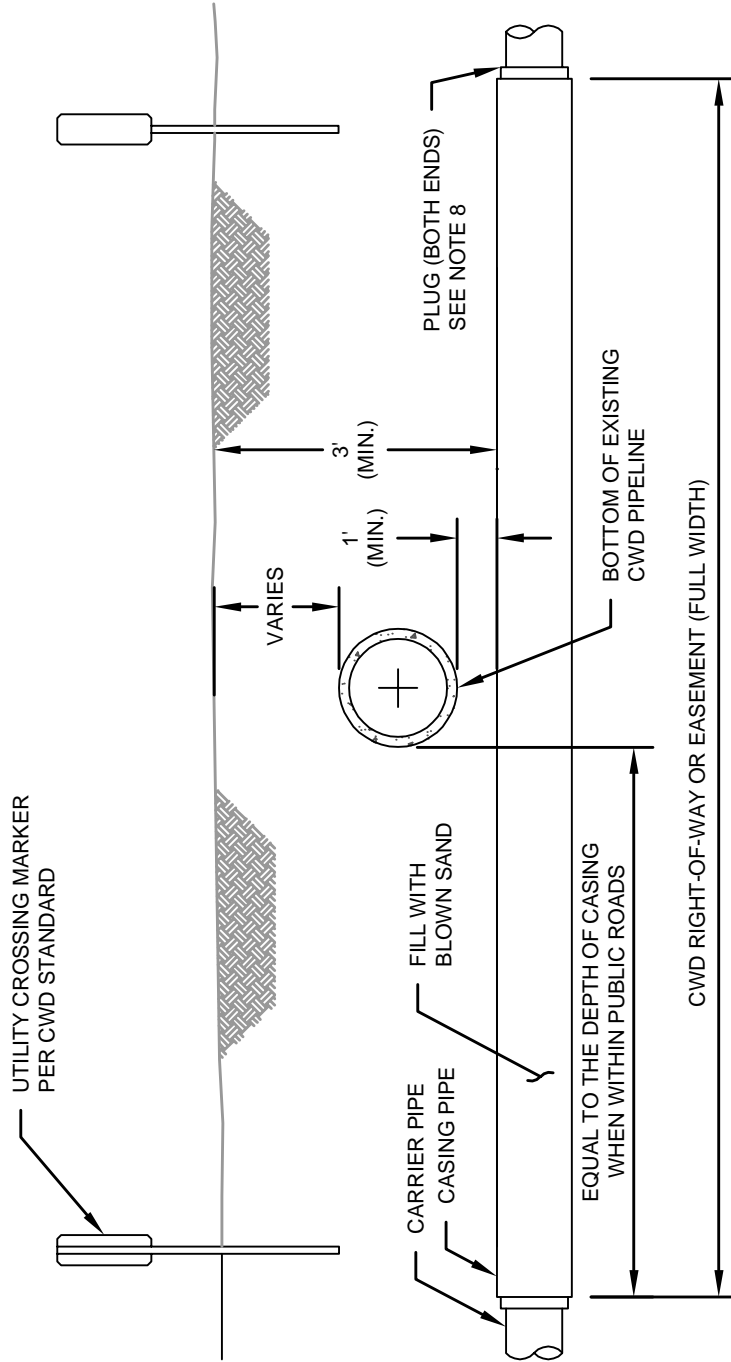

**UTILITY CROSSING BORING UNDER CWD PIPELINE**

NTS

**CHOWCHILLA**  
WATER DISTRICT

UTILITY CROSSING BORING DETAILS

SCALE: NOT TO SCALE

**U-2**

PREPARED BY: GJF, PAD

APPROVED BY: BT

DATE ADOPTED: 5-11-2022

SHEET 2 OF 3

**UTILITY CROSSING BORING NOTES**

1. WHENEVER ANY PROPOSED UTILITY IS TO CROSS EXISTING CWD FACILITIES (PIPELINE, UNLINED DITCH OR LINED CANAL) LYING WITHIN CWD RIGHT-OF-WAY OR CWD EASEMENTS, IT IS SHALL BE ACCOMPLISHED BY OPEN CUT AS SPECIFIED IN CWD STANDARD, UTILITY CROSSING OPEN CUT, OR HORIZONTAL AUGER BORING OF A STEEL CASING PIPE RUNNING CONTINUOUSLY THE FULL WIDTH OF THE PROPERTY OR EASEMENT AS SPECIFIED IN CWD STANDARD, UTILITY CROSSING BORING DETAILS. WHENEVER ANY PROPOSED UTILITY IS TO CROSS EXISTING CWD FACILITIES LYING WITHIN A NON-EXCLUSIVE EASEMENT OR PUBLIC RIGHT-OF-WAY, IT SHALL BE ACCOMPLISHED AS STATED ABOVE, EXCEPT THAT THE MINIMUM LENGTH OF THE CASING PIPE SHALL BE AS SHOWN ON SHEET 3 (WITHIN PUBLIC ROADS).
2. JACKING OF CASING PIPES WILL BE PERMITTED ONLY BY SPECIAL PERMISSION FROM THE CWD ENGINEER.
3. SLURRY BORING, TUNNELING AND WATER AUGER BORING WILL NOT BE PERMITTED.
4. BORING PITS AND RECEIVING PITS SHALL ONLY BE PLACED OUTSIDE OF CWD PROPERTY OR EASEMENTS. BORE PITS SHALL COMPLY WITH CAL-OSHA CONSTRUCTION SAFETY ORDERS. BORE PITS AND RECEIVING PITS SHALL BE SECURELY FENCED DURING NON-WORKING HOURS.
5. ONCE THE BORING OPERATION HAS COMMENCED, IT SHALL BE CONTINUED, UN-INTERRUPTED, AROUND THE CLOCK, UNTIL THE CASING PIPE HAS BEEN INSTALLED TO THE SPECIFIED LIMITS.
6. THE INSIDE DIAMETER OF THE CASING PIPES SHALL BE AS LARGE AS NECESSARY FOR THE INSTALLATION OF THE CARRIER PIPE AND SKIDS. IN NO CASE SHALL IT BE LESS THAN 6 INCHES LARGER THAN THE LARGEST OUTSIDE DIAMETER OF THE CARRIER PIPE. CASING PIPES SHALL CONFORM TO THE TABLE BELOW AND SHALL BE SEAMLESS OR WELDED SEAM PIPE AND IT SHALL BE COATED INSIDE WITH BITUMINOUS COATING. IF A BITUMINOUS COATING CANNOT BE USED ON THE INSIDE OF THE CASING PIPE, THE CASING PIPE MINIMUM THICKNESS SHALL BE INCREASED 1/16 OF AN INCH.

CASING THICKNESS:

| CASING I.D. | MINIMUM THICKNESS |
|-------------|-------------------|
| 4"-10"      | 1/4"              |
| 12"-36"     | 3/8"              |
| 42"-48"     | 1/2"              |
| LARGER      | BY DESIGN         |

7. CARRIER PIPES SHALL BE SUITABLE FOR TRANSPORTING THE PRODUCT INTENDED AND SHALL HAVE COMPRESSION SEALING JOINTS.
8. CASING PIPES FOR CARRIER PIPES TRANSPORTING PRODUCTS UNDER PRESSURE SHALL BE SEALED (PLUGGED) AT EACH END AND A VENT PIPE SHALL BE INSTALLED IF REQUIRED BY THE CWD ENGINEER. CASING PIPES FOR GRAVITY FLOW CARRIER PIPES NEED ONLY TO BE SEALED (PLUGGED) AT EACH END. CASING PIPES CARRYING ELECTRICAL CONDUCTORS SHALL BE GROUNDED WITH A GROUNDING ROD IN ACCORDANCE WITH THE NATIONAL ELECTRIC CODE.
9. BORING SHALL NOT BE PERFORMED DURING THE IRRIGATION SEASON (TYPICALLY MARCH 1ST TO OCTOBER 30TH) OR IN SATURATED GROUND WITHOUT SPECIFIC WRITTEN PERMISSION FROM THE CWD ENGINEER.
10. THE DIAMETER OF THE BORED HOLE SHALL NOT BE MORE THAN ONE INCH GREATER THAN THE CASING PIPE OUTSIDE DIAMETER. A SHIELD OR BAND MAY BE USED ON THE FIRST SECTION OF PIPE. VOIDS RESULTING FROM CAVING OR EXCAVATING OUTSIDE OF THE ABOVE LIMITS SHALL BE BACKFILLED WITH SAND OR GROUT BY AN APPROPRIATE METHOD WHICH WILL FILL THE VOIDS.
11. WHERE THE DEPTH OF CWD PIPELINE IS UNKNOWN, IT SHALL BE THE RESPONSIBILITY OF THE CONTRACTOR TO LOCATE THE PIPELINE. THE LEAST INVASIVE METHODS INCLUDING GROUND PENETRATING RADAR (GPR), HAND AUGERING, AND WATER JETTING WITH SLURRY BACKFILL SHALL BE PERMITTED. ALLOW ADEQUATE DEPTH OF CASING PIPE TO INSURE THE SPECIFIED MINIMUM CLEARANCE.
12. MARKERS SHALL BE PLACED AS SHOWN ON CWD STANDARD, UTILITY CROSSING MARKER DETAIL. EMERGENCY NOTIFICATION TELEPHONE NUMBER 911 IS NOT ACCEPTABLE.



**UTILITY CROSSING BORING DETAILS NOTES**

SCALE: NOT TO SCALE

**U-2**

DATE ADOPTED: 5-11-2022

SHEET 3 OF 3

PREPARED BY: GJF, PAD

APPROVED BY: BT

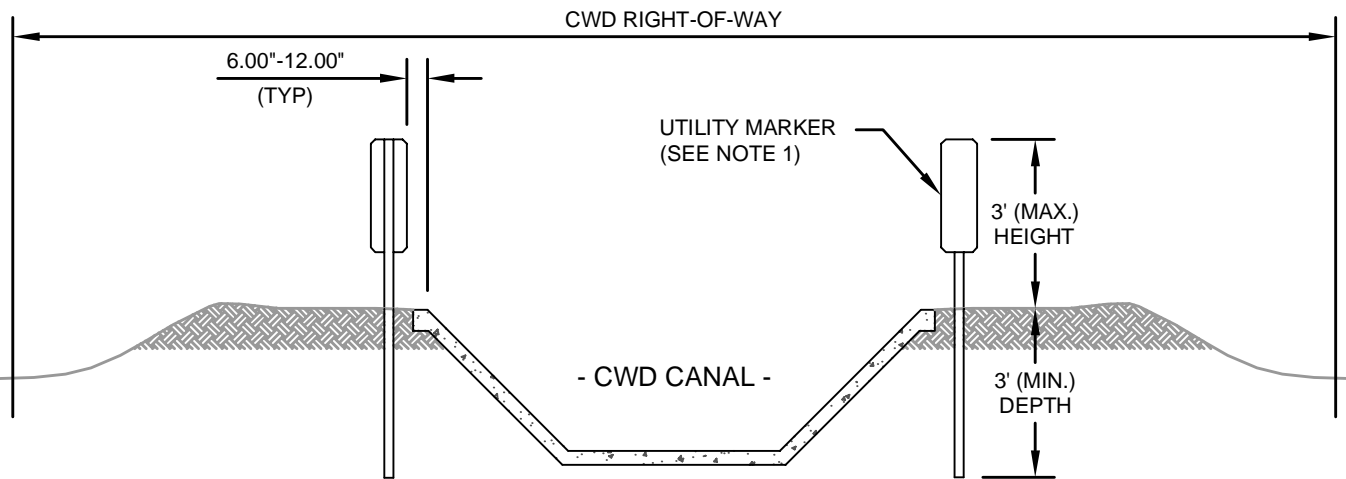

### UTILITY MARKER LOCATION

NTS

#### CONSTRUCTION NOTES

1. IRRIGATION UTILITY MARKER AND POST SHALL BE PLACED NOT MORE THAN 12 INCHES FROM TOP OF BANK CROWN ON EACH SIDE OF CANAL.
2. UTILITY MARKER POSTS SHALL BE STANDARD T-POST WITH 8" X 24" TYPE "A" OBJECT MARKER ATTACHED TO T-POST IN A MINIMUM OF 2 LOCATIONS WITH STEEL U-BOLTS.
3. UTILITY MARKER SHALL SHOW THE FOLLOWING INFORMATION: NUMBER OF PIPES, PIPE SIZES, PIPE MATERIAL, "IRRIGATION WATER LINE", OWNER OR FARM NAME. INFORMATION SHALL BE PERMANENTLY ATTACHED TO THE MARKER WITH PAINT OR OTHER CWD ENGINEER APPROVED SUITABLE METHOD.
4. WHEN UTILITY CROSSING OCCURS OUTSIDE OF THE PAVED OR TRAVELED WAY, INSTALL MARKERS AS SHOWN FACING THE CENTERLINE OF THE TRAVELED WAY. WHEN UTILITY CROSSING OCCURS WITHIN THE TRAVELED WAY, MARKERS MAY BE OMITTED.

INCLUDE APPROPRIATE INFORMATION

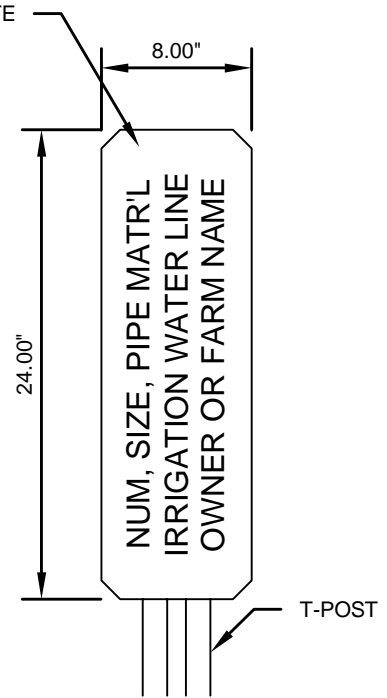

### MARKER INFORMATION

NTS

**CHOWCHILLA**  
WATER DISTRICT

**UTILITY CROSSING MARKER DETAIL**

SCALE: NOT TO SCALE

**U-3**

PREPARED BY: GJF, PAD

APPROVED BY: BT

DATE ADOPTED: 5-11-2022

SHEET 1 OF 1

APPROVAL  
OF  
MINUTES

This Page is Blank Intentionally



## **MINUTES OF THE BOARD OF DIRECTORS MEETING OF THE CHOWCHILLA WATER DISTRICT**

A special board meeting of the Board of Directors of the Chowchilla Water District was held on Wednesday, April 20, 2022 at 1:30 p.m. at the District Office at 327 S. Chowchilla Blvd.

Attendance:

Directors: Upton, Mandala, Taylor, Schuh, and Harris

CWD Staff: Tomlinson, Welch, and Beatty

President Upton called the meeting to order at 1:30 p.m.

**PUBLIC COMMENT:** Joel Hastings with Water Rights Newsletter, introduced himself.

**ADDITIONS TO THE AGENDA:** None

*At 1:32 p.m. the CWD Board of Directors went into recess and convened as CWD Groundwater Sustainability Agency at 1:32 p.m.*

**CWD GROUNDWATER SUSTAINABILITY AGENCY:**

**ADDITIONS TO THE CWD GSA AGENDA:** M/S Taylor/Schuh to add Item b to the agenda, discuss and may take action for a new well approval form. President Upton called for the vote and then publicly announced that the motion was unanimously approved by the Board.

Absent: Director Harris.

GRM Welch reported:

1. Chowchilla Subbasin technical staff, Davids Engineering and Luhdorff Scalmanini met with DWR staff a third time on March 16<sup>th</sup> to discuss DWR's Initial Review of the Chowchilla Subbasin Groundwater Sustainability Plan. The discussion issue was Subsidence.

*Director Harris joined the meeting @ 1:38 p.m.*

2. Davids Engineering completed the Annual Report for the Chowchilla Subbasin GSP and submitted to DWR
3. A Chowchilla Subbasin GSP Advisory Committee meeting was held on March 23<sup>rd</sup> at 1:30 pm.
4. Land Following – CWD added Land Following as a project in the Chowchilla Subbasin GSP.
5. Domestic Well Mitigation – the GSP Advisory Committee technical staff have begun discussions.
6. An application to DWR for grant funding for several projects (GSP Revisions Project, Triangle T Water District – Pipeline Extension Project, Sierra Vista Mutual Water Company – Recharge Basin Project, and Madera County – Chowchilla Subbasin Chowchilla Project 2) has been submitted.

GRM Welch provided a PowerPoint Presentation of the Chowchilla Subbasin 2022 Groundwater Sustainability Plan Annual Report, reviewing:

1. Groundwater Sustainability Plan (GSP) Annual Report Requirements
2. 2021 Surface Water System Budget
3. Groundwater Sustainability Agency (GS) Project Summary
4. Groundwater Conditions

**WELL APPLICATION FORM: M/S:** Mandala/Harris to approve the verification form for well permit application pursuant to State of California Executive Order N-7-22 #9a. President Upton called for the vote and then publicly announced that the motion was unanimously approved by the Board.

*At 2:23 p.m. the CWD Groundwater Sustainability Agency adjourned and reconvened as the CWD Board of Directors at 2:23 p.m.*

**FINANCIAL REPORT:** Lela Beatty reviewed the Treasurer's Report for the month ending March 31, 2022. **M/S** Mandala/Schuh to approve the Treasurer's Report as presented. President Upton called for the vote and then publicly announced that the Treasurer's Report was unanimously approved by the Board.

**M/S** Mandala/Schuh to approve payment of the bills listed on the disbursement journal dated April 20, 2022. President Upton called for the vote and then publicly announced that the payment journal dated April 20, 2022 was unanimously approved by the Board.

**MONTHLY SERVICE CONTRACT WITH EWELL GROUP:** It was the consensus of the Board to have The Ewell Group provide an in-person presentation.

**2022 BUDGET: M/S** Taylor/Schuh to approve the 2022 Budget as presented, with exception of setting the water rate a later date. President Upton called for the vote and then publicly announced that the motion was unanimously approved by the Board.

**RESOLUTION 2022-03: M/S** Mandala/Harris to approve Resolution 2022-03 – a resolution of the Board of Directors of the Chowchilla Water District estimating the sum of monies required by the District to discharge its obligations during 2022. President Upton called for vote and then publicly announced the motion was unanimously approved by the following vote:

Ayes: Directors Schuh, Harris, Taylor, Mandala, and Upton.

Noes: None

Absent: None

**MINUTES: M/S** Mandala/Schuh to approve the minutes of March 9, 2022. President Upton called for vote and then publicly announced the motion was unanimously approved by the Board.

**GENERAL MANAGER'S REPORT:** GM Tomlinson reported on maintenance activities, a detailed list of activities was included in the Board Packet including; Water Year 2022 precipitation and snow accumulation; BOR 15% Class 1 declaration; Exchange Contractors may call on Friant supply.

**2022 WATER SEASON:** Tabled to May Board Meeting

*Legal Counsel joined the meeting at 3:15 p.m.*

**CLOSED SESSION:** President Upton called the meeting into closed session at 3:05 p.m. to discuss Public Employee (Govt. Code, §54957) employment: and to conference with Legal Counsel (Govt. Code, §54956.9(d)(4)). President Upton called the meeting out of closed session at 3:32 p.m. and reported that no reportable action was taken.

**DIRECTORS REPORTS:** None

**ADJOURNMENT:** President Upton adjourned the meeting at 4:07 p.m.

Approved: \_\_\_\_\_  
President Kole Upton

Date Approved: \_\_\_\_\_

Attest: \_\_\_\_\_  
Brandon Tomlinson, Secretary

This Page is Blank Intentionally

OPERATION  
&  
MAINTENANCE  
REPORT

This Page is Blank Intentionally

# Board Report April

| <b>Equipment</b> | <b>Description</b>      | <b>Work Performance</b>                       |
|------------------|-------------------------|-----------------------------------------------|
| 1-13             | 2013 chevy 1500         | 5,000 Mile Service                            |
| 5-17             | 2017 Chevy 1500         | 5,000 Mile Service                            |
| 10-17            | 2017 Chevy 1500         | 5,000 Mile Service, Transmission Replaced     |
| 11-18            | 2018 Chevy 1500         | 5,000 Mile Service, Tires and Alignment       |
| 13               | 2007 F 150              | Replaced Battery                              |
| 18-12            | 2012 F450               | Repaired Headlight, Replaced Starter Cable    |
| 20-13            | 2013 F 450              | Recharged A/C                                 |
| 31<br>Gaskets    | 2006 Intl. Dump Truck   | Replaced Mudflap, Replaced Glad Hand          |
| 34-18            | 2018 CAT Loader         | Replaced Grease Fitting, Battery              |
| 37               | 1980 CAT Grader         | Welded Chain on Sloper, Replaced Diode        |
| 43-18            | 2018 Western Star Dump  | Tire Repair                                   |
| 50               | 2005 CAT Backhoe        | 250 Hour Service, Replaced Air Filter Housing |
| 55               | 1983 CAT Forklift       | Repaired Fuel Leak                            |
| 58               | 2001 Backhoe Trailer    | Repaired Wiring on Taillights                 |
| 63<br>Valve      | 1981 Joy Air Compressor | Repaired Wiring for Taillights, Replaced Ball |
| 67               | 2007 Concrete Trailer   | Replaced Toggle Switch For Water Nozzle       |

This Page is Blank Intentionally