



MANAGING RESOURCES FOR A BETTER FUTURE

DIRECTORS
NICK BRUNO, PRESIDENT
JEFFREY D. COULTHARD, VICE PRESIDENT
SHANNON SIMONIAN, TREASURER
ERIC BREAM
MATT CERNIGLIA
MIKE DELAGUERRA
HENK GRIFFIN

JULIA D. BERRY, GENERAL MANAGER/SECRETARY
BRIAN EHLERS, DISTRICT ENGINEER
FRANK SPLENDORIO, LEGAL COUNSEL

SPECIAL MEETING OF THE BOARD OF DIRECTORS

will be held on

Monday, May 11, 2026

11 a.m.

at

RCWD Wastewater Trailer

10772 Road 40

Madera, California 93636

1. CALL TO ORDER

2. PUBLIC COMMENT

Members of the public may address the Board on any matter related to the District that is not included on the Agenda. Comments are limited to three (3) minutes per person.

3. BOARD ACTION ITEMS

a. District Standards and Specifications – Review and consider taking action to update District Standard Specifications for Public Works Improvements.

- i. RCWD Standard Detail – Water Sample Station
- ii. RCWD Standard Detail – Storm Drainpipe

b. Wastewater Treatment Facility Board of Directors Walk Through

4. ADJOURN

- Items on the Agenda may be taken in any order.
- Action may be taken on any item listed on the Agenda.
- Writings relating to open session Agenda items that are distributed to members of the Board of Directors will be available for inspection at the District office, excluding writings that are not public records or are exempt from disclosure under the California Public Records Acts.
- ACCOMMODATIONS FOR PERSONS WITH DISABILITIES

A person with a qualifying disability under the Americans With Disabilities Act of 1990 may request the District to provide a disability-related modification or accommodation in order to participate in any public meeting of the District. Such assistance includes appropriate alternative formats for the agendas and agenda packets used for any public meetings of the District. Requests for such assistance and for agendas and agenda packets shall be made in person, by telephone, or by written correspondence to the District at (559) 283-8011 or P.O. Box 27950, Fresno, California 93720, at least 48 hours before a District meeting.

LEVINE ACT PUBLIC PARTY/APPLICANT DISCLOSURE OBLIGATIONS:

Applicants, parties, and their agents who have made campaign contributions totaling more than \$250 (aggregated) to a Board Member over the past 12 months, must publicly disclose that fact for the official record of that agenda item. Disclosures must include the amount of the campaign contribution aggregated, and the name(s) of the campaign contributor(s) and Board member(s). The disclosure may be made either in writing to the Clerk prior to the agenda item consideration, or by verbal disclosure at the time of the agenda item consideration.

SAMPLE STATION TAG REQUIREMENTS:

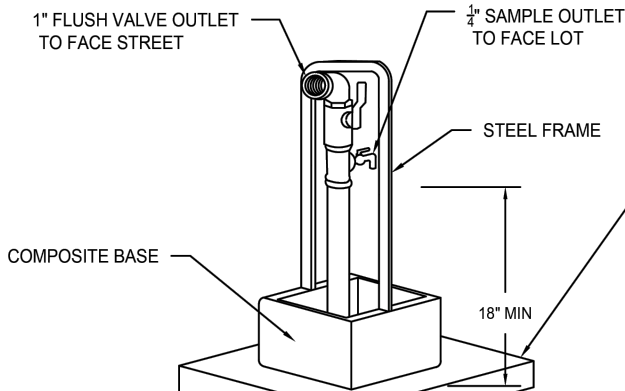
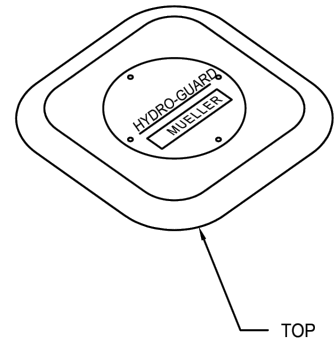
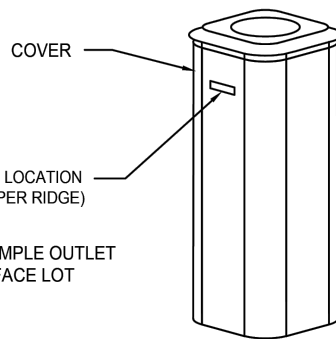
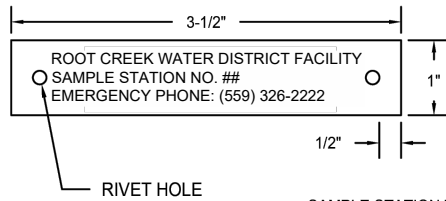

SAMPLING STATION SHALL BE SET MOUNTED TO A CONCRETE SLAB MEASURING 12" ON ALL SIDES, 6" THICK. IF COMBINED WITH OTHER SERVICES OR APPURTENANCES IN A SINGLE PAD THE PAD WILL INCLUDE DEEP SCORE JOINTS BETWEEN EACH ASSEMBLY. EXPOSED EDGES SHALL RECEIVE 1/2" RADIUS AND SURFACE SHALL RECEIVE A SWEAT FINISH.

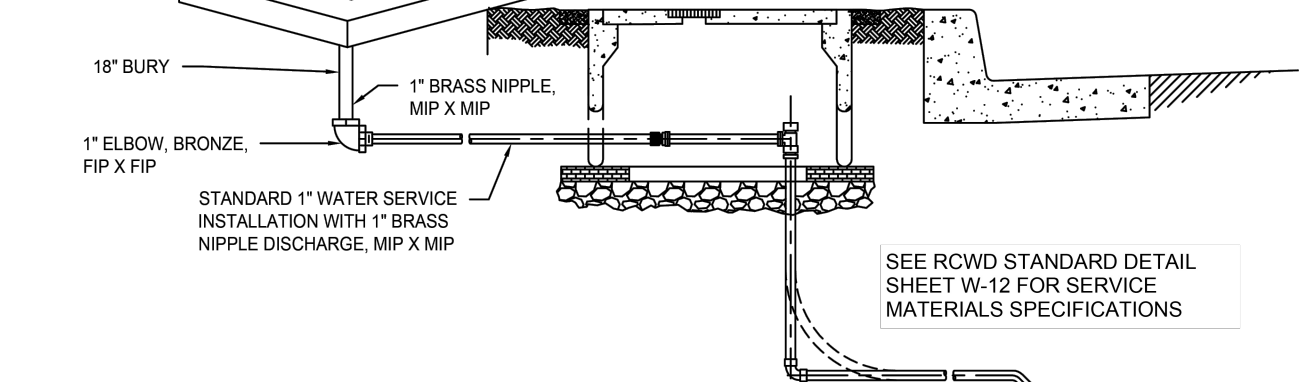

NOTES:

1. SAMPLING STATIONS SHALL BE MUELLER SAFETY GUARD BSS01 WITH 18" BURY, ALL BRASS PIPING, NO LEAD BRASS, REMOVABLE POWDER COATED STEEL ENCLOSURE, AND SECURITY KIT OR APPROVED EQUAL.
2. SAMPLING STATIONS SHALL BE 18" BURY, WITH A 1" FIP INLET AND A 1" FIP DISCHARGE. A 1/4" BENT-NOSE SAMPLING BIBB SHALL BE LOCATED BEFORE DISCHARGE. OUTLET PORTS SHALL BE POSITIONED WITH 180 DEGREES OF SEPARATION.
3. ALL STATIONS SHALL BE ENCLOSED IN A LOCKABLE, COMPOSITE HOUSING WITH INTEGRAL LOCK & FURNISH 2 KEYS PER UNIT.
4. WHEN OPENED, THE STATION SHALL REQUIRE NO KEY FOR OPERATION AND THE WATER SHALL FLOW IN ALL BRASS WATERWAY.
5. ALL WORKING PARTS SHALL BE OF BRASS AND SERVICEABLE FROM ABOVE GROUND WITH NO DIGGING.
6. A 1" BALL VALVE SHALL CONTROL THE WATER FLOW, AND SHALL BE LOCATED BEFORE THE SAMPLING BIBB.
7. SAMPLING STATION SHALL BE STANDARD FACTORY BLUE COLOR.
8. 1" WATER SERVICE ASSEMBLY SHALL BE INSTALLED PER DETAIL W-12.
9. ALL WATER SYSTEM MATERIALS THAT COME INTO CONTACT WITH POTABLE WATER SHALL BE ANSI/NSF STANDARD-61 CERTIFIED OR EQUIVALENT AND SHALL BE LEAD FREE.
10. ENCLOSURES SHALL INCLUDE BRONZE COLORED METAL ENGRAVED SAMPLE STATION TAGS FABRICATED BY SUNNYSIDE TROPHY 559-252-9273 OR APPROVED EQUAL. SAMPLE STATION TAGS SHALL BE ATTACHED TO PLASTIC COVER BY MEANS OF AN ADHESIVE BACKING AND 2 EACH RIVETED CONNECTION POINTS. SAMPLE STATION TAG TO BE LOCATED AS NOTED ABOVE FACING STREET.
11. FURNISH 1 EACH ASSEMBLED 1" X 20" BRASS NIPPLE, MIP X MIP AND 1" UNION, FIP X FIP. ASSEMBLED UNIT SHALL BE STORED LOOSE INSIDE ENCLOSURE AND WILL BE USED BY OPERATORS TO TEMPORARILY EXTEND THE FLUSH OUTLET DURING FLUSHING AND SAMPLING ACTIVITIES.

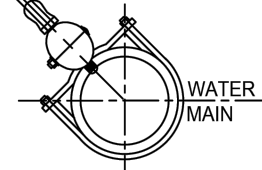

	ROOT CREEK WATER DISTRICT STANDARD DETAIL	WATER SAMPLE STATION INSTALLATION	
	PREPARED BY: STEPHEN GRISEZ NICK BRUNO, RCWD PRESIDENT	SCALE: NOT TO SCALE DATE ADOPTED:	W-11 SHEET 11 OF 39